

**CONNECTICUT  
RESOURCES  
RECOVERY  
AUTHORITY**

**REQUEST FOR BIDS  
("RFB")**

**FOR**

**REFURBISHMENT OF PRIMARY SHREDDERS CV-104/204  
AT THE  
MID-CONNECTICUT WASTE PROCESSING FACILITY  
(RFB Number FY08-OP-004)**

**BID DUE DATE  
November 21, 2007**

**Connecticut Resources Recovery Authority  
100 Constitution Plaza, 6<sup>th</sup> Floor  
Hartford, Connecticut 06103-1722**

**October 22, 2007**

# REQUEST FOR BIDS

For

## REFURBISHMENT OF PRIMARY SHREDDERS CV-104/204 AT THE MID-CONNECTICUT WASTE PROCESSING FACILITY (RFB Number 08-O-004)

Connecticut Resources Recovery Authority  
100 Constitution Plaza, 6<sup>th</sup> Floor  
Hartford, Connecticut 06103-1722

October 22, 2007

### TABLE OF CONTENTS

1. Notice To Contractors – Invitation To Bid
2. Instructions To Bidders
3. Bid Bond Form
4. Bid Form
5. Bid Price Form
6. References Form
7. Background And Experience Form
8. Questionnaire Concerning Affirmative Action, Small Business Contractors And Occupational Health And Safety
9. Affidavit Of Third Party Fees
10. Certification Concerning Nondiscrimination
11. Background Questionnaire
12. SEEC Form 11, Notice To Executive Branch State Contractors And Prospective State Contractors Of Campaign Contribution And Solicitation Ban
13. Notice Of Award
  - A. Contractor's Certification Concerning Gifts [To be executed by successful bidder]
14. Notice To Proceed
15. Refurbishment Of Primary Shredders CV-104/204 At The Mid-Connecticut Waste Processing Facility Agreement
  - A. Parts And Labor Specifications
  - B. Drawings
  - C. Project Schedule
  - D. Performance Bond Form and Letter Of Credit Form
  - E. Payment Bond Form (Included only for installation part of the Work)
  - F. Prevailing Wage Bid Package
  - G. Schedule Of Prevailing Wages
  - H. SEEC Form 11, Notice To Executive Branch State Contractors And Prospective State Contractors Of Campaign Contribution And Solicitation Ban

**REQUEST FOR BIDS  
FOR  
REFURBISHMENT OF  
PRIMARY SHREDDERS CV-104/204 AT THE  
MID-CONNECTICUT WASTE PROCESSING FACILITY**

**SECTION 1**

**NOTICE TO CONTRACTORS  
INVITATION TO BID**

# CONNECTICUT RESOURCES RECOVERY AUTHORITY

## NOTICE TO CONTRACTORS – INVITATION TO BID

The Connecticut Resources Recovery Authority (“CRRA”) is a quasi-public entity of the State of Connecticut that is responsible for implementing the State Solid Waste Management Plan and is currently providing solid waste disposal and recycling services to more than 100 municipalities in the state. One of CRRA’s facilities is the Mid-Connecticut Resource Recovery Facility (“RRF”), which is a waste-to-energy facility. The Mid-Connecticut RRF includes the Waste Processing Facility (“WPF”), which is the facility where Municipal Solid Waste (“MSW”) is converted into Refuse Derived Fuel (“RDF”). The WPF is operated by the Metropolitan District (the “District”) under contract to CRRA.

CRRA is seeking bids from qualified contractors to furnish all tools, materials, labor, equipment and incidentals thereto for refurbishing primary shredders CV-104/204 at the WPF. The work will involve preparation of engineering drawings of a variety of parts for the shredders and fabrication and installation of the parts. The primary shredders are critical pieces of equipment for the operation of the WPF. The installation work on each primary shredder will begin at 11:00 p.m. on a Friday and must be completed, with the shredder back in operation, by Tuesday at 7:00 a.m. The work will be subject to Connecticut’s prevailing wage requirements.

Request for Bid (“RFB”) package documents may be obtained Monday through Friday, from 8:30 a.m. to 5:00 p.m. at the offices of CRRA, 100 Constitution Plaza, 6<sup>th</sup> Floor, Hartford, Connecticut 06103-1722, beginning **Monday, October 22, 2007**. The documents will also be available beginning on the same date on the World Wide Web at <http://www.crra.org> under the “Business Opportunities” page.

There will be a mandatory pre-bid conference and tour of the site for all prospective bidders. **The mandatory pre-bid conference and tour will be held at the WPF at 10:00 a.m., Wednesday, October 31, 2007**. Any prospective bidder intending to participate in the tour must contact Rich Quelle, Project Engineer, at (860) 524-1695 at least 24 hours in advance of the pre-bid conference and site tour.

**Sealed bids must be received at the offices of CRRA, 100 Constitution Plaza, 6<sup>th</sup> Floor, Hartford, Connecticut 06103-1722 no later than 3:00 p.m., Wednesday, November 21, 2007.** Bids received after the time and date set forth above shall be rejected. All bids shall remain open for ninety (90) days after the bid due date.

Bids will be opened privately at CRRA’s convenience on or after the bid due date. Note that all information submitted by a firm responding to this RFQ is subject to the Freedom of Information Act.

All questions regarding this RFB must be submitted **in writing** to Rich Quelle, Project Engineer, by e-mail ([rquelle@crra.org](mailto:rquelle@crra.org)), by fax ((860) 757-7742), or by correspondence (CRRA, 100 Constitution Plaza, 6<sup>th</sup> Floor, Hartford, Connecticut 06103) no later than 3:00 p.m., Friday,

November 9, 2007. Any firm considering submitting a bid is prohibited from having any ex-parte communications with any CRRA staff member or CRRA Board member except Mr. Quelle.

**REQUEST FOR BIDS  
FOR  
REFURBISHMENT OF  
PRIMARY SHREDDERS CV-104/204 AT THE  
MID-CONNECTICUT WASTE PROCESSING FACILITY**

**SECTION 2  
INSTRUCTIONS TO BIDDERS**

# INSTRUCTIONS TO BIDDERS

## REFURBISHMENT OF PRIMARY SHREDDERS CV-104/204 AT THE MID-CONNECTICUT WASTE PROCESSING FACILITY

### CONTENTS

1.	Introduction .....	1
2.	RFB Projected Timeline.....	2
3.	Definitions.....	2
4.	Communications With CRRA Staff and Board Members .....	4
5.	Scope Of Work.....	4
6.	Bid Package Documents.....	4
7.	Mandatory Pre-Bid Conference And Site Tour.....	5
8.	Addenda And Interpretations .....	6
9.	Bid Submittal Procedures.....	6
10.	Bid Security.....	7
11.	Bid Contents.....	8
12.	Bid Opening .....	9
13.	Bid Evaluation.....	9
14.	Contract Award .....	10
15.	Contractor's Certification Concerning Gifts .....	10
16.	Prevailing Wage Requirements .....	11
17.	Bidder's Qualifications .....	11
18.	Bid Preparation And Other Costs.....	11

#### 1. Introduction

The Connecticut Resources Recovery Authority (“CRRA”) is a quasi-public entity of the State of Connecticut that is responsible for implementing the State Solid Waste Management Plan and is currently providing solid waste disposal and recycling services to more than 100 municipalities in the state. CRRA has developed, constructed and now operates an integrated system of four resources recovery facilities, two regional recycling centers, one MSW landfill, one combustor ash landfill, one bulky waste landfill and twelve transfer stations. At present, CRRA accepts more than 75% of the municipal solid waste generated in the State. These facilities are operated by entities that are under contract with CRRA.

One of CRRA’s facilities is the Mid-Connecticut Resource Recovery Facility (“RRF”), which is a waste-to-energy facility. The Mid-Connecticut RRF includes the Waste Process-

ing Facility (“WPF”), which is the facility where Municipal Solid Waste (“MSW”) is converted into Refuse Derived Fuel (“RDF”). The WPF is located at 300 Maxim Road, Gate 70, Hartford, Connecticut 06114 and is operated by the Metropolitan District (the “District”) under contract to CRRA.

CRRA is seeking bids from qualified contractors to furnish all tools, materials, labor, equipment and incidentals thereto for refurbishing primary shredders CV-104/204 at the WPF. The work will involve preparation of engineering drawings of a variety of parts for the shredders and fabrication and installation of the parts.

## 2. RFB Projected Timeline

The following is the projected timeline for the RFB process:

ITEM	DATE
RFB Documents Available	Monday, October 22, 2007
Pre-Bid Conference and Site Tour	Wednesday, October 31, 2007
Deadline for Written Questions	Friday, November 9, 2007
Response to Written Questions	No Later Than Friday, November 16, 2007
Bids Due at CRRA	Wednesday, November 21, 2007
Selection and Notice of Award Issued	Friday, December 21, 2007

CRRA reserves the right at its sole and absolute discretion to extend any of the actual or proposed dates in the above Projected Timeline and further reserves the right to reject any and all bids and republish this RFB. CRRA also reserves the right at its sole and absolute discretion to terminate this RFB process at any time prior to the execution of any Agreement.

Bidders should be aware that it may take up to four weeks from the time the successful bidder returns the executed Agreements to CRRA and meets all of the other conditions specified in the Notice Of Award until CRRA issues to the successful bidder a Notice To Proceed with the work for which it has been selected.

## 3. Definitions

As used in this Instructions To Bidders and in other Contract Documents (as defined herein), the following terms shall have the meanings as set forth below:

- (a) **Addenda:** Written or graphic documents issued prior to the bid due date that clarify, correct or change any or all of the Contract Documents.



(b) **Contract Documents:**

- (1) Refurbishment Of Primary Shredders CV-104/204 At The Mid-Connecticut Waste Processing Facility Agreement (the "Agreement");
- (2) Notice To Contractors – Invitation To Bid;
- (3) Instructions To Bidders;
- (4) Bid Bond Form;
- (5) Bid Form;
- (6) Bid Price Form;
- (7) References Form
- (8) Background And Experience Form;
- (9) Questionnaire Concerning Affirmative Action, Small Business Contractors And Occupational Health And Safety;
- (10) Affidavit Of Third Party Fees;
- (11) Certification Concerning Nondiscrimination;
- (12) Bidder's Background Questionnaire;
- (13) SEEC Form 11, Notice To Executive Branch State Contractors And Prospective State Contractors Of Campaign Contribution And Solicitation Ban;
- (14) Addenda;
- (15) Contractor's Bid (including all documentation attached to or accompanying such Bid, all other documentation submitted in connection with such Bid, and all post-bid documentation submitted prior to the Notice Of Award);
- (16) Notice Of Award, with Contractor Certification Concerning Gifts attached [to be executed by successful bidder];
- (17) Notice To Proceed; and
- (18) Any written amendments to the Agreement issued pursuant to Section 2.7 and Section 8.7 of the Agreement.

(c) **Laws And Regulations:** Any and all applicable laws, rules, regulations, ordinances, codes, orders and permits of any and all federal, state and local governmental and quasi-governmental bodies, agencies, authorities and courts having jurisdiction.

(d) **Notice Of Award:** Written notification from CRRA to the apparent successful bidder that states that CRRA has accepted such bidder's bid and sets forth the remaining conditions that must be fulfilled by such bidder before CRRA executes the Agreement.

(e) **Project:** The provision by the successful bidder(s) of the work required for refurbishment of primary shredders CV-104/204 at the Mid-Connecticut WPF, which may include preparing engineering drawings of a variety of parts for the shredders and fabrication and installation of the parts, in accordance with the Contract Documents.

- (f) **Property:** The certain parcel of real property located at 300 Maxim Road, Gate 70, Hartford, Connecticut, upon which property CRRA operates the Mid-Connecticut WPF.
- (g) **Site:** Those areas of the Property upon which any of the Work is to be performed, furnished and completed by the successful bidder in accordance with the Contract Documents.

Terms used, but not defined, in this Instructions To Bidders shall have the same respective meanings assigned to such terms in the Agreement.

#### **4. Communications With CRRA Staff and Board Members**

Except as otherwise authorized by this Instructions To Bidders, during the period while the RFB process is active (i.e., from the date CRRA issues the RFB until the date the successful bidder accepts the Notice Of Award), contractors contemplating or preparing bids are prohibited from contacting CRRA staff or CRRA Board of Director members in an ex parte manner to discuss the RFB submission process. A contractor's RFB submission shall be rejected if any of the foregoing ex parte communications take place.

#### **5. Scope Of Work**

CRRA is seeking bids from qualified contractors to furnish all tools, materials, labor, equipment and incidentals thereto for refurbishing primary shredders CV-104/204 at the WPF (the "Work"). The work to be performed under this Agreement includes, but is not limited to, the following items:

- (a) Generate engineering drawings that will be used to fabricate shredder parts including, but not limited to, the top cover, lower chute, bearing base, anvil plate and target plate of each shredder;
- (b) Fabrication of the required parts;
- (c) Installation of the parts.

Specific instructions about how the above Work is to be performed are included in **Exhibit A** (Parts And Labor Specifications) of the Agreement. The Work is more particularly shown on certain drawings entitled "Drawings," which drawings are set forth in **Exhibit B** of the Agreement.

#### **6. Bid Package Documents**

This RFB package consists of the following documents:

1. Notice To Contractors – Invitation To Bid;
2. Instructions To Bidders;
3. Bid Bond Form;

4. Bid Form;
5. Bid Price Form;
6. References Form;
7. Background And Experience Form;
8. Questionnaire Concerning Affirmative Action, Small Business Contractors And Occupational Health And Safety;
9. Affidavit Of Third Party Fees;
10. Certification Concerning Nondiscrimination;
11. Bidder's Background Questionnaire;
12. SEEC Form 11, Notice To Executive Branch State Contractors And Prospective State Contractors Of Campaign Contribution And Solicitation Ban;
13. Notice Of Award, with Contractor Certification Concerning Gifts attached [to be executed by successful bidder];
14. Notice To Proceed; and
15. Refurbishment Of Primary Shredders CV-104/204 At The Mid-Connecticut Waste Processing Facility Agreement, including:
  - A. Parts And Labor Specifications;
  - B. Drawings;
  - C. Project Schedule;
  - D. Performance Bond Form and Letter Of Credit Form;
  - E. Payment Bond;
  - F. Prevailing Wage Bid Package;
  - G. Schedule Of Prevailing Wages; and
  - H. SEEC Form 11, Notice To Executive Branch State Contractors And Prospective State Contractors Of Campaign Contribution And Solicitation Ban.

Complete sets of the above documents may be obtained Monday through Friday, from 8:30 a.m. to 5:00 p.m. at CRRA's offices 100 Constitution Plaza, 6<sup>th</sup> Floor, Hartford, Connecticut 06103-1722, beginning Monday, October 22, 2007.

All of the documents are also available in PDF format beginning on the same date on the World Wide Web at:

<http://www.crra.org> on the "Business Opportunities" page, under "RFB: Refurbishment Of Primary Shredders CV-104/204 At The Mid-Connecticut Waste Processing Facility" heading.

All of the forms included in the documents are available for downloading in Microsoft Word format at CRRA's web site. CRRA encourages bidders to make use of the downloaded Word forms.

## **7. Mandatory Pre-Bid Conference And Site Tour**

**A mandatory pre-bid conference and tour of the Site for all prospective bidders will be conducted by CRRA staff at 10:00 a.m. Eastern Time on Wednesday, October 31,**

**2007.** Bids submitted by a bidder who did not attend the mandatory pre-bid conference and site tour shall be rejected. Alternate times for visiting the Site will not be allowed.

Prospective bidders should contact Richard Quelle at (860) 524-1695 at least 24 hours prior to the mandatory pre-bid conference and site tour to make arrangements for participating in the tour and for directions to the Site. Except as otherwise authorized by this Instructions To Bidders, bidders are expressly prohibited from contacting any CRRA personnel regarding this bid solicitation.

## **8. Addenda And Interpretations**

CRRA may issue Addenda to this bid package that shall, upon issuance, become part of this package and binding upon all potential or actual bidders for the Work. Such Addenda may be issued in response to requests for interpretation or clarification received from potential bidders. Any request for interpretation or clarification of any documents included in this bid package must be **submitted in writing to Richard Quelle, Senior Engineer, by e-mail (rquelle@ crra.org), by fax ((860) 757-7742), or by correspondence (CRRA, 100 Constitution Plaza, 6<sup>th</sup> Floor, Hartford, Connecticut 06103-1722). To be given consideration, any such written request must be received by CRRA by 3:00 p.m., Friday, November 9, 2007.**

Addenda, if any, issued prior to the mandatory pre-bid conference and site tour will be mailed and/or e-mailed to all persons who picked up or requested a printed copy from CRRA of the bid package documents or who otherwise notified CRRA of their interest in the RFB. Such addenda will also be posted on CRRA's web site (<http://www.crra.org> on the "Business Opportunities" page under the "RFB: Refurbishment Of Primary Shredders CV-104/204 At The Mid-Connecticut Waste Processing Facility" heading).

Addenda issued after the mandatory pre-bid conference and site tour will be mailed and/or e-mailed to all persons who attended the pre-bid conference and site tour and will be posted on CRRA's web site (<http://www.crra.org> on the "Business Opportunities" page under the "RFB: Refurbishment Of Primary Shredders CV-104/204 At The Mid-Connecticut Waste Processing Facility" heading). Such addenda will be mailed/e-mailed and posted on the web site no later than three (3) days before the submittal deadline.

Failure of any bidder to receive any such Addenda shall not relieve such bidder from any conditions stipulated in such Addenda. Only questions answered or issues addressed by formal written Addenda will be binding. **All oral and other written responses, statements, interpretations or clarifications shall be without legal effect and shall not be binding upon CRRA.**

## **9. Bid Submittal Procedures**

**Sealed bids shall be submitted no later than 3:00 p.m., Eastern Time, Wednesday, November 21, 2007** at the offices of CRRA, 100 Constitution Plaza, 6th Floor, Hartford, Connecticut 06103-1722, Attn: Richard Quelle. Bids received after the time and date set forth above shall be rejected.

Each bidder must submit one (1) original and two (2) copies of its bid. The original bid shall be stamped or otherwise marked as such.

Each bid (the original and two copies) shall be enclosed in a sealed envelope that shall be clearly marked "Bid For Refurbishment Of Primary Shredders CV-104/204 At The Mid-Connecticut Waste Processing Facility."

Bids shall remain open and subject to acceptance for ninety (90) days after the bid due date.

**The terms and conditions of the Agreement (Section 15 of this RFB), as attached, are non-negotiable. Any potential bidder that will be unable to execute the Agreement, as attached, should not submit a bid.**

Bids may be modified or withdrawn by an appropriate document duly executed (in the manner that a bid must be executed) and delivered to the place where bids are to be submitted at any time prior to the bid due date.

## **10. Bid Security**

Each bid shall be accompanied by a Bid Security. Any bid that does not contain a Bid Security or any bid that contains a Bid Security that does not comply with the following requirements shall be rejected as non-responsive.

### **10.1 Type of Security**

The following are the acceptable forms of Bid Security:

- (a) A cashier's check;
- (b) A certified check; or
- (c) A bid bond in the form included in Section 3 of the RFB.

The Bid Security shall be made payable to CRRA and shall be in an amount equal to five percent (5%) of the amount of the bid.

Any bid bond submitted as Bid Security shall be in the form provided for such bid bond in Section 3 of the RFB and such bid bond shall be executed and issued by a surety company acceptable to CRRA.

### **10.2 Disposition of Bid Security**

The Bid Security of the successful bidder will be retained until such bidder has executed the Agreement, furnished the required contract security and satisfied all other conditions of the Notice of Award, including execution and submission of the Contractor Certification Concerning Gifts, whereupon such Bid Security will be returned.

If the successful bidder fails to execute and deliver the Agreement, furnish the required contract security, or satisfy all other conditions of the Notice Of Award within ten (10) days after the issuance of such Notice Of Award, CRRA may annul the Notice Of Award and the Bid Security of that bidder shall be forfeited.

The Bid Security of other bidders whom CRRA believes to have a reasonable chance of receiving the award may be retained by CRRA until the earlier of the seventh (7<sup>th</sup>) day after the Effective Date of the Agreement or ninety (90) days after the bid due date, whereupon the Bid Security furnished by such bidders will be returned. Bid Security with bids that are not competitive will be returned within seven (7) days after the opening of such bids.

## 11. Bid Contents

Bids shall be submitted on forms provided by CRRA as part of this bid package, all of which forms must be completed with the appropriate information required and all blanks on such forms filled in.

A bid must consist of the following and must be in the following order:

- (a) Title page;
- (b) Cover letter, which includes name of the bidder and the bidder's promise, if any, to set aside a portion of the contract for legitimate minority business enterprises (see Section 13.2 of this Instructions To Bidders);
- (c) Table of Contents;
- (d) Bid Security (cashier's check, certified check or bid bond) (see Section 10 of this Instructions To Bidders);
- (e) The Bid Form (Section 4), with Addenda, if any, listed in the appropriate place (Page 2), the name and address of the contact for Notices listed in the appropriate place (Page 7) and the completed agreement page (Page 7);
- (f) The completed Bid Price Form (Section 5);
- (g) The completed References Form (Section 6);
- (h) The completed Background And Experience Form (Section 7);
- (i) The completed Questionnaire Concerning Affirmative Action, Small Business Contractors And Occupational Health And Safety form (Section 8), with the Bidder's most recent EEO-1 data attached if the Bidder wishes such data to be considered in the evaluation of its Bid;
- (j) The completed Affidavit Of Third Party Fees form (Section 9) (subscribed and sworn before a Notary Public or Commissioner of the Superior Court);

- (k) The completed Certification Concerning Nondiscrimination (Section 10), with the bidder's nondiscrimination policies and procedures attached;
- (l) The completed Bidder's Background Questionnaire (Section 11); and
- (m) A copy of the bidder's up-to-date certificate of insurance showing all current insurance coverage.

Bidders should not include in their bids other portions of the Bid Package Documents (e.g., this Instructions To Bidders or the Agreement).

A bidder may include additional information as an addendum/appendix to its bid if the bidder thinks that it will assist CRRA in evaluating the bidder's bid. A bidder should not include information that is not directly related to the subject matter of this solicitation.

## 12. Bid Opening

All bids will be opened privately at CRRA's convenience on or after the bid due date.

**CRRA reserves the right to reject any or all of the bids, or any part(s) thereof, and/or to waive any informality or informalities in any bid or the RFB process for this Project.**

## 13. Bid Evaluation

The award of the contract for the Work will be made, if at all, to the bidder(s) whose evaluation by CRRA results in CRRA determining that such award to such bidder(s) is in the best interests of CRRA. **However, the selection of a bidder(s) and the award of such contract, while anticipated, are not guaranteed.**

CRRA is an Equal Opportunity and Affirmative Action employer and does not discriminate in its hiring, employment, contracting, or business practices. CRRA is committed to complying with the Americans with Disability Act of 1990 (ADA) and does not discriminate on the basis of disability in admission to, access to, or operation of its programs, services, or activities.

### 13.1 Evaluation Criteria

CRRA will base its evaluation of the bids on price, qualifications, demonstrated skill, ability and integrity of each bidder to perform the Work required by the Contract Documents and any other factor or criterion that CRRA, in its sole discretion, deems or may deem relevant or pertinent for such evaluation.

### 13.2 Affirmative Action Evaluation Criteria

Bids will also be rated on the bidder's demonstrated commitment to affirmative action. Sections 46a-68-1 to 46a-68-17 of the *Regulations of Connecticut State Agen-*

*cies* require CRRA to consider the following factors when awarding a contract that is subject to contract compliance requirements:

- (a) The bidder's success in implementing an affirmative action plan (See Question 4 of the Questionnaire Concerning Affirmative Action, Small Business Contractors And Occupational Health And Safety (Section 8 of this RFB));
- (b) The bidder's success in developing an apprenticeship program complying with Sections 46a-68-1 to 46a-68-17 of the *Regulations of Connecticut State Agencies*, inclusive (See Question 5 of the Questionnaire Concerning Affirmative Action, Small Business Contractors And Occupational Health And Safety (Section 8 of this RFB));
- (c) The bidder's promise to develop and implement a successful affirmative action plan (See Question 4B of the Questionnaire Concerning Affirmative Action, Small Business Contractors And Occupational Health And Safety (Section 8 of this RFB));
- (d) The bidder's submission of EEO-1 data indicating that the composition of its work force is at or near parity when compared to the racial and sexual composition of the work force in the relevant labor market area (See Section 11(i) of this Instructions To Bidders); and
- (e) The bidder's promise to set aside a portion of the contract for legitimate minority business enterprises (See Section 11(b) of this Instructions To Bidders).

#### **14. Contract Award**

If the contract is to be awarded, CRRA will issue to the successful bidder(s) a Notice Of Award within ninety (90) days after the bid due date.

CRRA reserves the right to correct inaccurate awards resulting from CRRA's clerical errors. This may include, in extreme circumstances, revoking a Notice Of Award already made to a bidder and subsequently awarding the Notice of Award to another bidder. Such action by CRRA shall not constitute a breach of this RFB by CRRA since the Notice Of Award to the initial bidder is deemed to be void ab initio and of no effect as if no Agreement ever existed between CRRA and the initial bidder.

#### **15. Contractor's Certification Concerning Gifts**

Pursuant to *Connecticut General Statutes* Section 4-252, the apparently successful bidder(s) must submit a document certifying that it has not given any gifts to certain individuals between the date CRRA started planning the RFB and the date the Agreement is executed. If the apparently successful Bidder does not execute the Certification, it will be disqualified for the Agreement. The dates between which the bidder may not give gifts and



the identities of those to whom it may not give gifts are specified in the attachment to the Notice Of Award included in this RFB (see Attachment A to Section 12 of the RFB).

**16. Prevailing Wage Requirements**

The Work, regardless of which part or parts of the Work the successful bidder(s) is selected, will be subject to the Prevailing Wage provisions of the *Connecticut General Statutes*. (See Section 8.7 of the Agreement.) In particular, within 30 days of receiving the contract award, the successful Bidder must furnish proof to the Connecticut Labor Commissioner that all of its employees and apprentices performing manual labor on the Project will have completed at 10-hour Occupational Safety and Health Administration (“OSHA”) construction safety and health course.

**17. Bidder’s Qualifications**

CRRA may make any investigation deemed necessary to determine the ability of any bidder to perform the Work required. Each bidder shall furnish CRRA with all such information as may be required for this purpose.

**18. Bid Preparation And Other Costs**

Each bidder shall be solely responsible for all costs and expenses associated with the preparation and/or submission of its bid, or incurred in connection with any interviews and negotiations with CRRA, and CRRA shall have no responsibility or liability whatsoever for any such costs and expenses.

**REQUEST FOR BIDS  
FOR  
REFURBISHMENT OF  
PRIMARY SHREDDERS CV-104/204 AT THE  
MID-CONNECTICUT WASTE PROCESSING FACILITY**

**SECTION 3**

**BID BOND FORM**

# BID/PROPOSAL BOND FORM

Any singular reference to Contractor, Surety, Owner or other party shall be considered plural where applicable. The below addresses are to be used for giving required notice.

**BIDDER/PROPOSER** (Name and Address):

**SURETY** (Name and Address of Principal Place of Business):

--	--

**OWNER** (Name and Address):

Connecticut Resources Recovery Authority 100 Constitution Plaza, 6 <sup>th</sup> Floor Hartford, CT 06103-1722
--

**BID/PROPOSAL**

<b>DUE DATE:</b>	
<b>AMOUNT:</b>	
<b>PROJECT DESCRIPTION</b> <small>(Including Name and Location):</small>	Refurbishment Of Primary Shredders CV-104/204 At The Mid Connecticut Waste Processing Facility Mid-Connecticut Waste Processing Facility 300 Maxim Road, Gate 70 Hartford, Connecticut 06114

**BOND**

<b>BOND NUMBER:</b>	
<b>DATE</b> (Not later than Bid/Proposal Due Date):	
<b>PENAL SUM:</b>	DOLLARS (\$ _____ )

IN WITNESS WHEREOF, Surety and Bidder/Proposer, intending to be legally bound hereby, subject to the terms printed on Page 2 hereof, do each cause this Bid/Proposal Bond to be duly executed on its behalf by its authorized officer, agent, or representative.

**BIDDER/PROPOSER**

**SURETY**

--

(SEAL)

--

(SEAL)

Bidder's Name and Corporate Seal

Surety's Name and Corporate Seal

<b>SIGNATURE:</b>		<b>SIGNATURE:</b>	
<b>NAME AND TITLE:</b>		<b>NAME AND TITLE:</b>	

## TERMS AND CONDITIONS TO BID/PROPOSAL BOND

1. Bidder/Proposer and Surety, jointly and severally, bind themselves, their heirs, executors, administrators, successors and assigns to pay to Owner upon default of Bidder/Proposer any difference between the total amount of Bidder's/Proposer's bid/proposal and the total amount of the bid/proposal of the next lowest, responsible and responsive bidder/proposer as determined by Owner for the Work/Service required by the Contract Documents, provided that:
  - 1.1 If there is no such next lowest, responsible and responsive bidder/proposer, and Owner does not abandon the Project, then Bidder/Proposer and Surety shall pay to Owner the penal sum set forth on the face of this Bond, and
  - 1.2 In no event shall Bidder's/Proposer's and Surety's obligation hereunder exceed the penal sum set forth on the face of this Bond.
2. Default of Bidder/Proposer shall occur upon the failure of Bidder/Proposer to deliver within the time required by the Bid/Proposal Documents (or any extension thereof agreed to in writing by Owner) the executed Agreement and related documents required by the Bid/Proposal Documents and any performance and payment bonds required by the Bid/Proposal Documents and Contract Documents.
3. This obligation shall be null and void if:
  - 3.1 Owner accepts Bidder's/Proposer's bid/proposal and bidder/proposer delivers within the time required by the Bid/Proposal Documents (or any extension thereof agreed to in writing by Owner) the executed Agreement and related documents required by the Bid/Proposal Documents and any performance and payments bonds required by the Bid/Proposal Documents and Contract Documents, or
  - 3.2 All bids/proposals are rejected by Owner, or
  - 3.3 Owner fails to issue a notice of award to Bidder/Proposer within the time specified in the Bid/Proposal Documents (or any extension thereof agreed to in writing by Bidder/Proposer and, if applicable, consented to by Surety when required by paragraph 5 hereof).
4. Payment under this Bond will be due and payable upon default by Bidder/Proposer and within 30 calendar days after receipt by Bidder/Proposer and Surety of written notice of default from Owner, which notice will be given with reasonable promptness, identifying this Bond and the Project and including a statement of the amount due.
5. Surety waives notice of any and all defenses based on or arising out of any time extension to issue notice of award agreed to in writing by Owner and Bidder/Proposer, provided that the total time for issuing notice of award including extensions shall not in the aggregate exceed 120 days from Bid/Proposal Due Date without Surety's written consent.
6. No suit or action shall be commenced under this Bond prior to 30 calendar days after the notice of default required in paragraph 4 above is received by Bidder/Proposer and Surety and in no case later than one year after Bid/Proposal Due Date.
7. Any suit or action under this Bond shall be commenced only in a court of competent jurisdiction located in the state in which the Project is located.
8. Notices required hereunder shall be in writing and sent to Bidder/Proposer and Surety at their respective addresses shown on the face of this Bond. Such notices may be sent by personal delivery, commercial courier or by United States Registered or Certified Mail, return receipt requested, postage pre-paid, and shall be deemed to be effective upon receipt by the party concerned.
9. Surety shall cause to be attached to this Bond a current and effective Power of Attorney evidencing the authority of the officer, agent or representative who executed this Bond on behalf of Surety to execute, seal and deliver such Bond and bind the Surety thereby.
10. This Bond is intended to conform to all applicable statutory requirements. Any applicable requirement of any applicable statute that has been omitted from this Bond shall be deemed to be included herein as if set forth at length. If any provision of this Bond conflicts with any applicable provision of any applicable statute, then the provision of said statute shall govern and the remainder of this Bond that is not in conflict therewith shall continue in full force and effect.

**REQUEST FOR BIDS  
FOR  
REFURBISHMENT OF  
PRIMARY SHREDDERS CV-104/204 AT THE  
MID-CONNECTICUT WASTE PROCESSING FACILITY**

**SECTION 4  
BID FORM**



**BID FORM**

**PROJECT:** Mid-Connecticut

**RFB NUMBER:** FY08-OP-004

**CONTRACT FOR:** Refurbishment Of Primary Shredders CV-104/204 At The Mid-Connecticut Waste Processing Facility

**BIDS SUBMITTED TO:** Connecticut Resources Recovery Authority  
100 Constitution Plaza, 6<sup>th</sup> Floor  
Hartford, Connecticut 06103-1722

**1. DEFINITIONS**

Unless otherwise defined herein, all terms that are not defined and used in this Bid Form (a "Bid") shall have the same respective meanings assigned to such terms in the Contract Documents.

**2. TERMS AND CONDITIONS**

The undersigned (the "Bidder") accepts and agrees to all terms and conditions of the Request For Bids, Instructions To Bidders, the Agreement and any Addenda to any such documents. This Bid shall remain open and subject to acceptance for ninety (90) days after the bid due date.

If CRRA issues a Notice Of Award to Bidder, Bidder shall within ten (10) days after the date thereof:

- (a) Execute and deliver to CRRA the required number of counterparts of the non-negotiable Agreement;
- (b) Execute and deliver to CRRA the Contractor's Certification Concerning Gifts;
- (c) Execute and deliver to CRRA all other Contract Documents attached to the Notice Of Award along with any other documents required by the Contract Documents; and
- (d) Satisfy all other conditions of the Notice Of Award.

**3. BIDDER'S OBLIGATIONS**

Bidder proposes and agrees, if this Bid is accepted by CRRA and CRRA issues a Notice Of Award to Bidder, to the following:

- (a) To perform, furnish and complete all the Work as specified or indicated in the Contract Documents and Agreement for the Bid Price and within the Contract Time set forth in this Bid and in accordance with the terms and conditions of the Contract Documents and Agreement; and
- (b) At the request of CRRA and if the successful Bidder qualifies, to apply with the State of Connecticut Department Administrative Services, and do all that is necessary to make itself qualify, as a Small Contractor and/or Minority/Women/Disabled Person Business Enterprise in accordance with Section 4a-60g of the *Connecticut General Statutes*.

**4. BIDDER'S REPRESENTATIONS CONCERNING NON-NEGOTIABILITY OF THE AGREEMENT**

In submitting this Bid, Bidder acknowledges and agrees that the terms and conditions of the Agreement (including all Exhibits thereto), as included in the RFB, are non-negotiable, and Bidder is willing to and shall, if CRRA accepts its Bid for the Work and issues a Notice Of Award to Bidder, execute such Agreement. However, CRRA reserves the right to negotiate with Bidder over Bidder's price for the Work submitted on its Bid Price Form.

**5. BIDDER'S REPRESENTATIONS CONCERNING EXAMINATION OF CONTRACT DOCUMENTS**

In submitting this Bid, Bidder represents that:

- (a) Bidder has thoroughly examined and carefully studied the RFB package documents and the following Addenda, receipt of which is hereby acknowledged (list Addenda by Addendum number and date):

Addendum Number	Date Issued

- (b) Without exception the Bid is premised upon performing, furnishing and completing the Work required by the Contract Documents and applying the

specific means, methods, techniques, sequences or procedures (if any) that may be shown, indicated or expressly required by the Contract Documents;

- (c) Bidder is fully informed and is satisfied as to all Laws and Regulations that may affect cost, progress, performance, furnishing and/or completion of the Work;
- (d) Bidder has studied and carefully correlated Bidder's knowledge and observations with the Contract Documents and such other related data;
- (e) Bidder has given CRRA written notice of all conflicts, errors, ambiguities and discrepancies that Bidder has discovered in the Contract Documents and the written resolutions thereof by CRRA are acceptable to Bidder;
- (f) If Bidder has failed to promptly notify CRRA of all conflicts, errors, ambiguities and discrepancies that Bidder has discovered in the Contract Documents, such failure shall be deemed by both Bidder and CRRA to be a waiver to assert these issues and claims in the future;
- (g) Bidder is aware of the general nature of work to be performed by CRRA and others that relates to the Work for which this Bid is submitted; and
- (h) The Contract Documents are generally sufficient to indicate and convey understanding by Bidder of all terms and conditions for performing, furnishing and completing the Work for which this Bid is submitted.

## **6. BIDDER'S REPRESENTATIONS CONCERNING SITE CONDITIONS**

In submitting this Bid, Bidder acknowledges and agrees that:

- (a) All information and data included in this RFB package relating to the surface, subsurface and other conditions of the Site are from presently available sources and are being provided only for the information and convenience of the bidders;
- (b) CRRA does not assume any responsibility for the accuracy or completeness of such information and data, if any, shown or indicated in the Contract Documents with respect to any surface, subsurface or other conditions of the Site(s);
- (c) Bidder is solely responsible for investigating and satisfying itself as to all actual and existing Site conditions, including surface conditions, subsurface conditions and underground facilities; and
- (d) Bidder has visited the Site and has become familiar with and is satisfied as to the general, local, and site conditions that may affect cost, progress, performance, furnishing and completion of the Work.



**7. BIDDER'S REPRESENTATIONS CONCERNING INFORMATION MADE AVAILABLE**

In submitting this Bid, Bidder acknowledges and agrees that Bidder shall not use any information made available to it or obtained in any examination made by it in connection with this RFB in any manner as a basis or grounds for a claim or demand of any nature against CRRA arising from or by reason of any variance which may exist between information offered or so obtained and the actual materials, conditions, or structures encountered during performance of any of the Work.

**8. BIDDER'S REPRESENTATIONS CONCERNING STATE OF CONNECTICUT TAXES**

In submitting this Bid, Bidder acknowledges and agrees that CRRA is exempt from all State of Connecticut taxes and assessments, including sales and use taxes. Accordingly, Bidder shall not charge CRRA any State of Connecticut taxes or assessments at any time in connection with Bidder's performance of this Agreement, nor shall Bidder include any State of Connecticut taxes or assessments in any rates, costs, prices or other charges to CRRA hereunder. Bidder represents and warrants that no State of Connecticut taxes or assessments were included in any rates, costs, prices or other charges presented to CRRA in any bid or other submittal to CRRA in connection with this RFB.

**9. BIDDER'S REPRESENTATIONS CONCERNING DISCLOSURE OF INFORMATION**

In submitting this Bid, Bidder:

- (a) Recognizes and agrees that CRRA is subject to the Freedom of Information provisions of the *Connecticut General Statutes* and, as such, any information contained in or submitted with or in connection with Bidder's Bid is subject to disclosure if required by law or otherwise; and
- (b) Expressly waives any claim(s) that Bidder or any of its successors and/or assigns has or may have against CRRA or any of its directors, officers, employees or authorized agents as a result of any such disclosure.

**10. BIDDER'S REPRESENTATIONS CONCERNING NON-COLLUSION**

By submission of this Bid, the Bidder, together with any affiliates or related persons, the guarantor and any joint ventures, hereby represents that, under risk of termination of the Agreement, if awarded, to the best of its knowledge and belief:

- (a) The prices in the Bid have been arrived at as the result of an independent business judgment without collusion, consultation, communication, agreement or otherwise for the purpose of restricting competition, as to any matter relating to such prices and any other person or company;

- (b) Unless otherwise required by law, the prices that have been quoted in this Bid have not, directly or indirectly, been knowingly disclosed by the Bidder prior to "opening" to any other person or company;
- (c) No attempt has been made or will be made by the Bidder to induce any other person, partnership or corporation to submit, or not to submit, a bid for the purpose of restricting competition;
- (d) Bidder has not directly or indirectly induced or solicited any other bidder to submit a false or sham bid; and
- (e) Bidder has not sought by collusion to obtain for itself any advantage for the Work over any other bidder for the Work or over CRRA.

#### **11. BIDDER'S REPRESENTATIONS CONCERNING RFB FORMS**

By submission of this Bid, the Bidder, together with any affiliates or related business entities or persons, the guarantor and any joint ventures, hereby represents that, under risk of termination of the Agreement, if awarded, all of the forms included in the RFB that are submitted to CRRA as part of its Bid are identical in form and content to the preprinted forms in the RFB except that information requested by the forms has been inserted in the spaces on the forms provided for the insertion of such requested information.

#### **12. BIDDER'S WAIVER OF DAMAGES**

Bidder and all its affiliates and subsidiaries understand that by submitting a Bid, Bidder is acting at its and their own risk and Bidder does for itself and all its affiliates, subsidiaries, successors and assigns hereby waive any rights any of them may have to receive any damages for any liability, claim, loss or injury resulting from:

- (a) Any action or inaction on the part of CRRA or any of its directors, officers, employees or authorized agents concerning the evaluation, selection, non-selection and/or rejection of any or all bids by CRRA or any of its directors, officers, employees or authorized agents;
- (b) Any agreement entered into for the Work (or any part thereof) described in the Contract Documents; and/or
- (c) Any award or non-award of a contract for the Work (or any part thereof) pursuant to the Contract Documents.

#### **13. BIDDER'S REPRESENTATION REGARDING THE CONNECTICUT CAMPAIGN CONTRIBUTION AND SOLICITATION BAN**

With regard to a State contract as defined in P.A. 07-1 having a value in a calendar year of \$50,000 or more or a combination or series of such agreement or contracts having a value of \$100,000 or more, the authorized signatory to this submission in response to CRRA's solicitation expressly acknowledges receipt of the State Elections Enforcement

Commission's notice advising prospective state contractors of state campaign contribution and solicitation prohibitions, and will inform its principals of the contents of the notice. See Section 12 [SEEC Form 11] of the Contract Documents.

#### **14. ATTACHMENTS**

The following documents are attached hereto and made a part of this Bid:

- (a) The completed Bid Price Form;
- (b) The completed References Form;
- (c) The completed Background And Experience Form;
- (d) Questionnaire Concerning Affirmative Action, Small Business Contractors And Occupational Health and Safety that has been completely filled out by the Bidder;
- (e) Affidavit Of Third Party Fees that has been completely filled out by Bidder and signed before a Notary Public or Commissioner of the Superior Court;
- (f) Certification Concerning Nondiscrimination that has been completely filled out and signed by Bidder, with the Bidder's nondiscrimination policies and procedures attached;
- (g) Background Questionnaire that has been completely filled out by the Bidder and signed before a Notary Public or Commissioner of the Superior Court; and
- (h) A copy of the Bidder's up-to-date certificate of insurance showing all current insurance coverage.

#### **15. NOTICES**

Communications concerning this Bid should be addressed to Bidder at the address set forth below.

Bidder Name:	
Bidder Contact:	
Title:	
Address:	
Telephone Number:	
Fax Number:	
E-Mail Address:	

**16. ADDITIONAL REPRESENTATION**

Bidder hereby represents that the undersigned is duly authorized to submit this Bid on behalf of Bidder.

**AGREED TO AND SUBMITTED ON** \_\_\_\_\_, 200\_\_

Name of Bidder (Firm):	
Signature of Bidder Representative:	
Name (Typed/Printed):	
Title (Typed/Printed):	

**REQUEST FOR BIDS  
FOR  
REFURBISHMENT OF  
PRIMARY SHREDDERS CV-104/204 AT THE  
MID-CONNECTICUT WASTE PROCESSING FACILITY**

**SECTION 5**

**BID PRICE FORM**



<b>BID PRICE FORM</b>
-----------------------

Bidder will complete the Work as specified in the Contract Documents for the refurbishment of Primary Shredders CV-104/204 at the Mid-Connecticut Waste Processing Facility for the following lump sum bid price (please use tables below).

Dollars	Cents
(Use Numbers)	

(Use Words)

Bidder affirms that the total bid price above represents the entire cost to complete the Work in accordance with the Contract Documents, and that no claim will be made on account of any increase in wage scales, material prices, delivery delays, taxes, insurance, cost indexes or any other rates affecting the construction industry or this Project, and that each and every such claim is hereby expressly waived by Bidder.

Name of Bidder (Firm):	
Signature of Bidder Representative:	
Name (Type/Print):	
Title:	
Date:	

**REQUEST FOR BIDS  
FOR  
REFURBISHMENT OF  
PRIMARY SHREDDERS CV-104/204 AT THE  
MID-CONNECTICUT WASTE PROCESSING FACILITY**

**SECTION 6**

**REFERENCES FORM**



# REFERENCES FORM

In space below, provide the names of three (3) references who can attest to the quality of work performed/services provided by Bidder/Proposer. Include job title, affiliation, address, phone number and a brief description of the work performed/services provided for each reference.

## REFERENCE 1

Name of Person:	
Title:	
Name of Firm:	
Address:	
Telephone Number:	
Description Of Work Performed:	

## REFERENCE 2

Name of Person:	
Title:	
Name of Firm:	
Address:	
Telephone Number:	
Description Of Work Performed:	



**REFERENCE 3**

Name of Person:	
Title:	
Name of Firm:	
Address:	
Telephone Number:	
Description Of Work Performed:	

**REQUEST FOR BIDS  
FOR  
REFURBISHMENT OF  
PRIMARY SHREDDERS CV-104/204 AT THE  
MID-CONNECTICUT WASTE PROCESSING FACILITY**

**SECTION 7**

**BACKGROUND AND EXPERIENCE FORM**

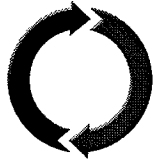

CONNECTICUT  
RESOURCES  
RECOVERY  
AUTHORITY

## BACKGROUND AND EXPERIENCE FORM

### BACKGROUND AND EXPERIENCE FORM

In the space below, summarize work performed/services provided of a similar nature to that specified in the Contract Documents which has been performed by the bidder/proposer and which will enable CRRA to evaluate the experience and professional capabilities of the bidder/proposer.

[Attach Additional Pages If Necessary]

**REQUEST FOR BIDS  
FOR  
REFURBISHMENT OF  
PRIMARY SHREDDERS CV-104/204 AT THE  
MID-CONNECTICUT WASTE PROCESSING FACILITY**

**SECTION 8**

**QUESTIONNAIRE CONCERNING AFFIRMATIVE  
ACTION, SMALL BUSINESS CONTRACTORS  
AND OCCUPATIONAL HEALTH AND SAFETY**



**QUESTIONNAIRE CONCERNING AFFIRMATIVE ACTION, SMALL BUSINESS CONTRACTORS AND OCCUPATIONAL HEALTH AND SAFETY**

Because CRRA is a political subdivision of the State of Connecticut, it is required by various statutes and regulations to obtain background information on prospective contractors prior to entering into a contract. The questions below are designed to assist CRRA in procuring this information. Many of the questions are required to be asked by RCSA 46a-68j-31. For the purposes of this form, "Contractor" means Bidder or Proposer, as appropriate.

	Yes	No
1. Is the Contractor an Individual? <i>If you answered "Yes" to Question 1, skip to Question 2. If you answered "No" to Question 1, proceed to Question 1A and then to Question 2.</i>	<input type="checkbox"/>	<input type="checkbox"/>
1A. How many employees does the Contractor have? <input type="text"/>		
2. Is the Contractor a Small Contractor based on the criteria in Schedule A? <i>If you answered "Yes" to Question 2, proceed to Question 2A and then to Question 3. If you answered "No" to Question 2, skip to Question 3.</i>	<input type="checkbox"/>	<input type="checkbox"/>
2A. Is the Contractor registered with the DAS as a Certified Small Business? <i>If you answered "Yes" to Question 2A, please provide a copy of your Set-Aside Certificate.</i>	<input type="checkbox"/>	<input type="checkbox"/>
3. Is the Contractor a MWDP Business Enterprise based on the criteria in Schedule B? <i>If you answered "Yes" to Question 3, proceed to Question 3A and then to Question 4. If you answered "No" to Question 3, skip to Question 4.</i>	<input type="checkbox"/>	<input type="checkbox"/>
3A. Is the Contractor registered with DAS as a MWDP Small Business?	<input type="checkbox"/>	<input type="checkbox"/>
4. Does the Contractor have an Affirmative Action Plan? <i>If you answered "Yes" to Question 4, proceed to Question 4A and then to Question 5. If you answered "No" to Question 4, skip to Question 4B and then to Question 5.</i>	<input type="checkbox"/>	<input type="checkbox"/>
4A. Has the Affirmative Action Plan been approved by the CHRO?	<input type="checkbox"/>	<input type="checkbox"/>
4B. Will the Contractor develop and implement an Affirmative Action Plan?	<input type="checkbox"/>	<input type="checkbox"/>
5. Does the Contractor have an apprenticeship program complying with RCSA 46a-68-1 through 46a-68-17?	<input type="checkbox"/>	<input type="checkbox"/>
6. Has the Contractor been cited for three or more willful or serious violations of any occupational safety and health act?	<input type="checkbox"/>	<input type="checkbox"/>
7. Has the Contractor received one or more criminal convictions related to the injury or death of any employee in the three-year period preceding the issuance of this Request For Bids/Proposals/Qualifications?	<input type="checkbox"/>	<input type="checkbox"/>
8. Has the Contractor been the recipient of one or more ethical violations from the State of Connecticut Ethics Commission during the three-year period preceding the issuance of this Request For Bids/Proposals/Qualifications?	<input type="checkbox"/>	<input type="checkbox"/>
9. Will subcontractors be involved? <i>If you answered "Yes" to Question 9, proceed to Question 9A. If you answered "No" to Question 9, you are finished with the questionnaire.</i>	<input type="checkbox"/>	<input type="checkbox"/>
9A. How many subcontractors will be involved? <input type="text"/>		

## LIST OF ACRONYMS

RCSA	-	Regulations of Connecticut State Agencies
CHRO	-	State of Connecticut Commission on Human Rights and Opportunities
DAS	-	State of Connecticut Department of Administrative Services
MWDP	-	Minority/Women/Disabled Person

## FOOTNOTE

- <sup>1</sup> If the Contract is a "public works contract" (as defined in Section 46a-68b of the Connecticut General Statutes), the dollar amount exceeds \$50,000.00 in any fiscal year, and the Contractor has 50 or more employees, the Contractor, in accordance with the provisions of Section 46a-68c of the Connecticut General Statutes, shall develop and file an affirmative action plan with the Connecticut Commission on Human Rights and Opportunities.

## SCHEDULE A CRITERIA FOR A SMALL CONTRACTOR

Contractor must meet all of the following criteria to qualify as a Small Contractor:

1. Has been doing business and has maintained its principal place of business in the State for a period of at least one year immediately preceding the issuance of the Request For Bids/Proposals/Qualifications;
2. Has had gross revenues not exceeding ten million dollars in the most recently completed fiscal year;
3. Is headquartered in Connecticut; and,
4. At least 51% of the ownership of the Contractor is held by a person or persons who are active in the daily affairs of the business and have the power to direct the management and policies of the business.

## SCHEDULE B CRITERIA FOR A MINORITY/WOMAN/DISABLED PERSON BUSINESS ENTERPRISE

Contractor must meet all of the following criteria to qualify as a Minority/Woman/Disabled Person Business Enterprise:

1. Satisfies all of the criteria in Schedule A for a Small Contractor;
2. 51% or more of the business and/or its assets must be owned by a person or persons who are minorities as defined in Connecticut General Statutes Section 32-9n (please see below) or is an individual with a disability;
3. The Minority/Woman/Disabled Person must have the power to change policy and management of the business; and,
4. The Minority/Woman/Disabled Person must be active in the day-to-day affairs of the business.

## CONNECTICUT GENERAL STATUTES SECTION 32-9n

Sec. 32-9n. Office of Small Business Affairs. (a) There is established within the Department of Economic and Community Development an Office of Small Business Affairs. Such office shall aid and encourage small business enterprises, particularly those owned and operated by minorities and other socially or economically disadvantaged individuals in Connecticut. As used in this section, minority means: (1) Black Americans, including all persons having origins in any of the Black African racial groups not of Hispanic origin; (2) Hispanic Americans, including all persons of Mexican, Puerto Rican, Cuban, Central or South American, or other Spanish culture or origin, regardless of race; (3) all persons having origins in the Iberian Peninsula, including Portugal, regardless of race; (4) women; (5) Asian Pacific Americans and Pacific islanders; or (6) American Indians and persons having origins in any of the original peoples of North America and maintaining identifiable tribal affiliations through membership and participation or community identification.

**REQUEST FOR BIDS  
FOR  
REFURBISHMENT OF  
PRIMARY SHREDDERS CV-104/204 AT THE  
MID-CONNECTICUT WASTE PROCESSING FACILITY**

**SECTION 9**

**AFFIDAVIT OF THIRD PARTY FEES**



# AFFIDAVIT OF THIRD PARTY FEES (Form A2)

All Bidders/Proposers must complete and properly execute this Affidavit of Third Party Fees. The purpose of this Affidavit is to ascertain if the Bidder/Proposer has made or promised any payment to a third party attributable to this Agreement. If no such payment has been made or promised, Bidder/Proposer should write "None" in the first box in the table and execute this Affidavit. For purposes of the Affidavit, Bidder's/Proposer's subcontractors, if any, are not considered third parties.

I, \_\_\_\_\_, a duly authorized officer and/or representative of \_\_\_\_\_ (firm name), being duly sworn, hereby depose and say that:

1. I am over eighteen (18) years of age and believe in the obligations of an oath;
2. \_\_\_\_\_ (firm name) seeks to enter into the Refurbishment Of Steel Pan Conveyor CV-101 At The Mid-Connecticut Waste Processing Facility Agreement (the "Agreement") with the Connecticut Resources Recovery Authority; and
3. All third party fees and agreements to pay third party fees attributable to the "Agreement" are as follows:

Name Of Payee	Dollar Amount Paid Or Value Of Non-Cash Compensation <u>AND</u> Date	Fee Arrangement	Specific Services Performed Or To Be Performed By Payee <sup>1</sup>

*(Attach additional copies of this page as necessary.)*

**NOTE:** For each third party fee arrangement described above (if any), complete the attached Form A2a.

4. The information set forth herein is true, complete and accurate to the best of my knowledge and belief under penalty of perjury.

Signed: \_\_\_\_\_

Name (Print): \_\_\_\_\_

Title: \_\_\_\_\_

Sworn to before me this \_\_\_\_\_ day of \_\_\_\_\_ 200 \_\_\_\_\_

\_\_\_\_\_  
Notary Public/Commissioner of the Superior Court

<sup>1</sup> Please attach documents evidencing the terms of the fee arrangement and services.





**ADDENDUM TO  
AFFIDAVIT OF THIRD PARTY FEES  
(Form A2a)**

For each third party fee arrangement disclosed in the attached Affidavit, please explain whether and how each such payment falls within one or more of the following categories of compensation:

- (1) Compensation earned for the rendering of legal services when provided by an attorney while engaged in the ongoing practice of law;
- (2) Compensation earned for the rendering of investment services, other than legal services, when provided by an investment professional while engaged in the ongoing business of providing investment services;
- (3) Compensation for placement agent, due diligence or comparable tangible marketing services when paid to a person who is an investment professional (i) engaged in the ongoing business of representing providers of investment services, or (ii) in connection with the issuance of bonds, notes or other evidence of indebtedness by a public agency;
- (4) Compensation earned by a licensed real estate broker or real estate salesperson while engaging in the real estate business on an ongoing basis; or
- (5) Payments for client solicitation activities meeting the requirements of Rule 206(4)-3 under the Investment Advisers Act of 1940.

***Attach additional pages as necessary.***

**REQUEST FOR BIDS  
FOR  
REFURBISHMENT OF  
PRIMARY SHREDDERS CV-104/204 AT THE  
MID-CONNECTICUT WASTE PROCESSING FACILITY**

**SECTION 10**

**CERTIFICATION CONCERNING  
NONDISCRIMINATION**



**CERTIFICATION CONCERNING  
NONDISCRIMINATION**

(This certification must be executed by an individual or business entity submitting a bid/proposal to the Connecticut Resources Recovery Authority regarding support of nondiscrimination against persons on account of their race, color, religious creed, age, marital or civil union status, national origin, ancestry, sex, mental retardation, physical disability or sexual orientation.)

I, \_\_\_\_\_, a duly authorized officer and/or representative  
of \_\_\_\_\_ (firm name),  
(the "Consultant"), hereby certify that:

1. Consultant seeks to enter into the Refurbishment Of Primary Shredders CV-1-4/204 At The Mid-Connecticut Waste Processing Facility Agreement (the "Agreement") with the Connecticut Resources Recovery Authority; and
2. In carrying out its obligation under the Agreement, Consultant will abide by the nondiscrimination agreements and warranties required under Connecticut General Statutes Sections 4a-60(a)(1) and 4a-60a(a)(1), as amended in State of Connecticut Public Act 07-245 and Sections 9(a)(1) and 10(a)(1) of Public Act 07-142; and
3. Attached are the policies and procedures concerning nondiscrimination, which have not been modified or rescinded, adopted by the appropriate governing body or management of Consultant; and
4. The information set forth herein is true, complete and accurate to the best of my knowledge and belief.

IN WITNESS WHEREOF, the undersigned has executed this certificate this

\_\_\_\_\_ day of \_\_\_\_\_ 200 \_\_\_\_\_

By (Signature): \_\_\_\_\_

Name (Print): \_\_\_\_\_

Title: \_\_\_\_\_

**REQUEST FOR BIDS  
FOR  
REFURBISHMENT OF  
PRIMARY SHREDDERS CV-104/204 AT THE  
MID-CONNECTICUT WASTE PROCESSING FACILITY**

**SECTION 11**

**BACKGROUND QUESTIONNAIRE**



**BIDDER'S/PROPOSER'S BACKGROUND QUESTIONNAIRE**

Please answer the following questions by placing an "X" in the appropriate box.

	Yes	No
<p>1. Has the Bidder/Proposer or any of its principals, owners, officers, partners, directors or stockholders holding more than 50% of the stock of the Bidder/Proposer ever been the subject of a <b>criminal</b> investigation?</p> <p><i>If you answered "Yes" to Question 1, proceed to Question 1A and, on a separate sheet of paper, state the following: the court in which the investigation is taking or took place; the approximate date the investigation commenced and, if applicable, concluded; the subject matter of the investigation; and the identity of the person or entity involved.</i></p> <p><i>If you answered "No" to Question 1, proceed to Question 2.</i></p>	<input type="checkbox"/>	<input type="checkbox"/>
<p>1A. Has any indictment arisen out of any such investigation?</p> <p><i>If you answered "Yes" to Question 1A, proceed to Question 2 and, on a separate sheet of paper, state the following: the name of the person or entity indicted; and the status of any such indictment.</i></p> <p><i>If you answered "No" to Question 1A, proceed to Question 2.</i></p>	<input type="checkbox"/>	<input type="checkbox"/>
<p>2. Has the Bidder/Proposer or any of its principals, owners, officers, partners, directors or stockholders holding more than 50% of the stock of the Bidder/Proposer ever been the subject of a <b>civil</b> investigation?</p> <p><i>If you answered "Yes" to Question 2, proceed to Question 3 and, on a separate sheet of paper, state the following: the court or other forum in which the investigation took or is taking place; the approximate date the investigation commenced and, if applicable, concluded; the subject matter of the investigation; the identity of the person or entity involved; and the status of the investigation.</i></p> <p><i>If you answered "No" to Question 2, proceed to Question 3.</i></p>	<input type="checkbox"/>	<input type="checkbox"/>
<p>3. Has any entity (e.g., corporation, partnership, etc.) in which a principal, owner, officer, partner, director or stockholder of the Bidder/Proposer has an ownership interest in excess of 50% in such entity ever been the subject of a <b>criminal</b> investigation?</p> <p><i>If you answered "Yes" to Question 3, proceed to Question 3A and, on a separate sheet of paper, state the following: the court in which the investigation is taking or took place; the approximate date the investigation commenced and, if applicable, concluded; the subject matter of the investigation; and the identity of the person or entity involved.</i></p> <p><i>If you answered "No" to Question 3, proceed to Question 4.</i></p>	<input type="checkbox"/>	<input type="checkbox"/>
<p>3A. Has any indictment arisen out of any such investigation?</p> <p><i>If you answered "Yes" to Question 3A, proceed to Question 4 and, on a separate sheet of paper, state the following: the name of the person or entity indicted; and the status of any such indictment.</i></p> <p><i>If you answered "No" to question 3A, proceed to Question 4.</i></p>	<input type="checkbox"/>	<input type="checkbox"/>
<p>4. Has any entity (e.g., corporation, partnership, etc.) in which a principal, owner, officer, partner, director or stockholder of the Bidder/Proposer has an ownership interest in excess of 50% in such entity ever been the subject of a <b>civil</b> investigation?</p> <p><i>If you answered "Yes" to Question 4, on a separate sheet of paper state the following: the court in which the investigation is taking or took place; the approximate date the investigation commenced and, if applicable, concluded; the subject matter of the investigation; the identity of the person or entity involved; and the status of the investigation.</i></p>	<input type="checkbox"/>	<input type="checkbox"/>

	Yes	No
5. Has the Bidder/Proposer or any of its principals, owners, officers, partners, directors or stockholders holding more than 50% of the stock of the Bidder/Proposer ever been debarred from bidding on, or otherwise applying for, any contract with the State of Connecticut or any other governmental authority? <i>If you answered "Yes" to Question 5, on a separate sheet of paper please explain.</i>	<input type="checkbox"/>	<input type="checkbox"/>

Signature: \_\_\_\_\_  
 Name (print/type): \_\_\_\_\_  
 Title: \_\_\_\_\_  
 State Of: \_\_\_\_\_  
 County Of: \_\_\_\_\_

\_\_\_\_\_, being fully sworn, deposes and says that  
 he/she is the \_\_\_\_\_ (Title) of  
 \_\_\_\_\_ (Firm Name),  
 the Bidder/Proposer herein, that he/she has provided answers to the foregoing questions on the Bidder's/  
 Proposer's background, and, under the penalty of perjury, certifies that each and every answer is true.

Sworn to before me this \_\_\_\_\_ day of \_\_\_\_\_ 200\_\_

\_\_\_\_\_  
 Notary Public/Commissioner of the Superior Court

**REQUEST FOR BIDS  
FOR  
REFURBISHMENT OF  
PRIMARY SHREDDERS CV-104/204 AT THE  
MID-CONNECTICUT WASTE PROCESSING FACILITY**

**SECTION 12**

**SEEC FORM 11  
NOTICE TO EXECUTIVE BRANCH STATE  
CONTRACTORS AND PROSPECTIVE STATE  
CONTRACTORS OF CAMPAIGN CONTRIBUTION  
AND SOLICITATION BAN**

## SEEC FORM 11

### **NOTICE TO EXECUTIVE BRANCH STATE CONTRACTORS AND PROSPECTIVE STATE CONTRACTORS OF CAMPAIGN CONTRIBUTION AND SOLICITATION BAN**

This notice is provided under the authority of Connecticut General Statutes 9-612(g)(2), as amended by P.A. 07-1, and is for the purpose of informing state contractors and prospective state contractors of the following law (italicized words are defined on the following page):

#### **Campaign Contribution and Solicitation Ban**

No *state contractor, prospective state contractor, principal of a state contractor or principal of a prospective state contractor*, with regard to a *state contract or state contract solicitation* with or from a state agency in the executive branch or a quasi-public agency or a holder, or principal of a holder of a valid prequalification certificate, shall make a contribution to, or *solicit* contributions on behalf of (i) an exploratory committee or candidate committee established by a candidate for nomination or election to the office of Governor, Lieutenant Governor, Attorney General, State Comptroller, Secretary of the State or State Treasurer, (ii) a political committee authorized to make contributions or expenditures to or for the benefit of such candidates, or (iii) a party committee;

In addition, no holder or principal of a holder of a valid prequalification certificate, shall make a contribution to, or solicit contributions on behalf of (i) an exploratory committee or candidate committee established by a candidate for nomination or election to the office of State senator or State representative, (ii) a political committee authorized to make contributions or expenditures to or for the benefit of such candidates, or (iii) a party committee.

#### **Duty to Inform**

State contractors and prospective state contractors are required to inform their principals of the above prohibitions, as applicable, and the possible penalties and other consequences of any violation thereof.

#### **Penalties for Violations**

Contributions or solicitations of contributions made in violation of the above prohibitions may result in the following civil and criminal penalties:

Civil penalties--\$2000 or twice the amount of the prohibited contribution, whichever is greater, against a principal or a contractor. Any state contractor or prospective state contractor which fails to make reasonable efforts to comply with the provisions requiring notice to its principals of these prohibitions and the possible consequences of their violations may also be subject to civil penalties of \$2000 or twice the amount of the prohibited contributions made by their principals.

Criminal penalties—Any knowing and willful violation of the prohibition is a Class D felony, which may subject the violator to imprisonment of not more than 5 years, or \$5000 in fines, or both.

#### **Contract Consequences**

Contributions made or solicited in violation of the above prohibitions may result, in the case of a state contractor, in the contract being voided.

Contributions made or solicited in violation of the above prohibitions, in the case of a prospective state contractor, shall result in the contract described in the state contract solicitation not being awarded to the prospective state contractor, unless the State Elections Enforcement Commission determines that mitigating circumstances exist concerning such violation.

The State will not award any other state contract to anyone found in violation of the above prohibitions for a period of one year after the election for which such contribution is made or solicited, unless the State Elections Enforcement Commission determines that mitigating circumstances exist concerning such violation.

Additional information and the entire text of P.A 07-1 may be found on the website of the State Elections Enforcement Commission, [www.ct.gov/seec](http://www.ct.gov/seec). Click on the link to "State Contractor Contribution Ban."



Definitions:

"State contractor" means a person, business entity or nonprofit organization that enters into a state contract. Such person, business entity or nonprofit organization shall be deemed to be a state contractor until December thirty-first of the year in which such contract terminates. "State contractor" does not include a municipality or any other political subdivision of the state, including any entities or associations duly created by the municipality or political subdivision exclusively amongst themselves to further any purpose authorized by statute or charter, or an employee in the executive or legislative branch of state government or a quasi-public agency, whether in the classified or unclassified service and full or part-time, and only in such person's capacity as a state or quasi-public agency employee.

"Prospective state contractor" means a person, business entity or nonprofit organization that (i) submits a response to a state contract solicitation by the state, a state agency or a quasi-public agency, or a proposal in response to a request for proposals by the state, a state agency or a quasi-public agency, until the contract has been entered into, or (ii) holds a valid prequalification certificate issued by the Commissioner of Administrative Services under section 4a-100. "Prospective state contractor" does not include a municipality or any other political subdivision of the state, including any entities or associations duly created by the municipality or political subdivision exclusively amongst themselves to further any purpose authorized by statute or charter, or an employee in the executive or legislative branch of state government or a quasi-public agency, whether in the classified or unclassified service and full or part-time, and only in such person's capacity as a state or quasi-public agency employee.

"Principal of a state contractor or prospective state contractor" means (i) any individual who is a member of the board of directors of, or has an ownership interest of five per cent or more in, a state contractor or prospective state contractor, which is a business entity, except for an individual who is a member of the board of directors of a nonprofit organization, (ii) an individual who is employed by a state contractor or prospective state contractor, which is a business entity, as president, treasurer or executive vice president, (iii) an individual who is the chief executive officer of a state contractor or prospective state contractor, which is not a business entity, or if a state contractor or prospective state contractor has no such officer, then the officer who duly possesses comparable powers and duties, (iv) an officer or an employee of any state contractor or prospective state contractor who has *managerial or discretionary responsibilities with respect to a state contract*, (v) the spouse or a *dependent child* who is eighteen years of age or older of an individual described in this subparagraph, or (vi) a political committee established or controlled by an individual described in this subparagraph or the business entity or nonprofit organization that is the state contractor or prospective state contractor.

"State contract" means an agreement or contract with the state or any state agency or any quasi-public agency, let through a procurement process or otherwise, having a value of fifty thousand dollars or more, or a combination or series of such agreements or contracts having a value of one hundred thousand dollars or more in a calendar year, for (i) the rendition of services, (ii) the furnishing of any goods, material, supplies, equipment or any items of any kind, (iii) the construction, alteration or repair of any public building or public work, (iv) the acquisition, sale or lease of any land or building, (v) a licensing arrangement, or (vi) a grant, loan or loan guarantee. "State contract" does not include any agreement or contract with the state, any state agency or any quasi-public agency that is exclusively federally funded, an education loan or a loan to an individual for other than commercial purposes.

"State contract solicitation" means a request by a state agency or quasi-public agency, in whatever form issued, including, but not limited to, an invitation to bid, request for proposals, request for information or request for quotes, inviting bids, quotes or other types of submittals, through a competitive procurement process or another process authorized by law waiving competitive procurement.

"Managerial or discretionary responsibilities with respect to a state contract" means having direct, extensive and substantive responsibilities with respect to the negotiation of the state contract and not peripheral, clerical or ministerial responsibilities.

"Dependent child" means a child residing in an individual's household who may legally be claimed as a dependent on the federal income tax of such individual.

"Solicit" means (A) requesting that a contribution be made, (B) participating in any fund-raising activities for a candidate committee, exploratory committee, political committee or party committee, including, but not limited to, forwarding tickets to potential contributors, receiving contributions for transmission to any such committee or bundling contributions, (C) serving as chairperson, treasurer or deputy treasurer of any such committee, or (D) establishing a political committee for the sole purpose of soliciting or receiving contributions for any committee. Solicit does not include: (i) making a contribution that is otherwise permitted by Chapter 155 of the Connecticut General Statutes; (ii) informing any person of a position taken by a candidate for public office or a public official, (iii) notifying the person of any activities of, or contact information for, any candidate for public office; or (iv) serving as a member in any party committee or as an officer of such committee that is not otherwise prohibited in this section.

**REQUEST FOR BIDS  
FOR  
REFURBISHMENT OF  
PRIMARY SHREDDERS CV-104/204 AT THE  
MID-CONNECTICUT WASTE PROCESSING FACILITY**

**SECTION 13**

**NOTICE OF AWARD**



## NOTICE OF AWARD

**TO:** [NAME OF SUCCESSFUL BIDDER]  
[ADDRESS OF SUCCESSFUL BIDDER]

**PROJECT:** Mid-Connecticut

**RFB NO.:** FY08-OP-004

**CONTRACT:** Refurbishment Of Primary Shredders CV-104/204 At The Mid-Connecticut Waste Processing Facility

The Connecticut Resources Recovery Authority ("CRRA") has considered the Bid submitted by you dated [DATE] in response to CRRA's Notice To Contractors – Invitation To Bid for the above-referenced Work, which Work is more particularly described in the Refurbishment Of Primary Shredder CV-104/204 At The Mid-Connecticut Waste Processing Facility Agreement (the "Work").

You are hereby notified that your Bid has been accepted of the Work. The amount of the award for the Work is \$[CONTRACT PRICE].

Within ten (10) days from the date of this Notice of Award you are required to:

- (a) Execute the required number of the attached counterparts of the non-negotiable Agreement and deliver such executed counterparts to CRRA;
- (b) Execute the attached Contractor's Certification Concerning Gifts and deliver such executed Certification to CRRA;
- (c) Deliver to CRRA the requisite certificates of insurance;
- (d) Deliver to CRRA all other Contract Documents attached to the Notice Of Award; and
- (e) Satisfy all other conditions set forth herein.

**As you have agreed, the terms and conditions of the Agreement, as attached, are non-negotiable.**

If you fail within ten (10) days from the date of this Notice Of Award to perform and complete any of your obligations set forth in items (a) through (e) above, CRRA will be entitled to consider all your rights arising out of CRRA's acceptance of your Bid as abandoned and terminated. CRRA will also be entitled to such other rights and remedies as may be granted at law or in equity.

You are required to acknowledge your receipt of this Notice Of Award by signing below and returning the same to CRRA.

Dated this [DAY] day of [MONTH], [YEAR].

Connecticut Resources Recovery Authority

By: \_\_\_\_\_  
[NAME OF CRRA OFFICIAL]  
Title: [TITLE OF CRRA OFFICIAL]

**ACCEPTANCE OF NOTICE**

Receipt of this NOTICE OF AWARD is hereby acknowledged this \_\_\_\_\_ day of \_\_\_\_\_, 200\_.

By:

Signature: \_\_\_\_\_

Name (print/type): \_\_\_\_\_

Title: \_\_\_\_\_

**ATTACHMENT A**

**To**

**NOTICE OF AWARD**

**CONTRACTORS CERTIFICATION CONCERNING  
GIFTS**



## CONTRACTOR'S CERTIFICATION CONCERNING GIFTS

### REFURBISHMENT OF PRIMARY SHREDDERS CV-104/204 AT THE MID-CONNECTICUT WASTE PROCESSING FACILITY

(This CERTIFICATION is to be signed by an authorized officer of the Contractor or the Contractor's managing general partner.)

Section 4-252 of the *Connecticut General Statutes* requires that a Contractor (i.e., the successful bidder/proposer for an Agreement) complete and properly execute this Certification Concerning Gifts at the same time that the Contractor executes the Agreement. If the Contractor fails to make the required certifications, the Contractor shall be disqualified for the Agreement.

I, \_\_\_\_\_, a duly authorized officer and/or representative of \_\_\_\_\_ (firm name) (the "Contractor"), being duly sworn, hereby depose and say that:

1. I am over eighteen (18) years of age and believe in the obligations of an oath; and
2. The Contractor has submitted a bid/proposal for the Refurbishment Of Primary Shredders CV-104/204 At The Mid-Connecticut Waste Processing Facility Agreement (the "Agreement") to the Connecticut Resources Recovery Authority ("CRRA"), has been selected by CRRA as the successful bidder/proposer for the Agreement and is prepared to enter into the Agreement with CRRA; and
3. No gifts were made between April 1, 2007 and the date of execution of the Agreement, by
  - (a) The Contractor,
  - (b) Any principals and key personnel of the Contractor who participated substantially in preparing the Contractor's bid/proposal for or the negotiation of the Agreement, or
  - (c) Any agent of the Contractor or principals and key personnel who participated substantially in preparing the Contractor's bid/proposal for or the negotiation of the Agreement

to

- (1) Any public official or employee of CRRA who participated substantially in the preparation of the bid/proposal solicitation for or the negotiation or award of the Agreement (such CRRA employees are listed in Table 2 below), or
- (2) Any public official or state employee of any state agency who has supervisory or appointing authority over CRRA (such public officials and state employees are listed in Table 3 below); and

4. No such principals and key personnel of the Contractor or agent of the Contractor or principals and key personnel knows of any action by Contractor to circumvent the prohibition on gifts by providing for any other principals and key personnel, official, employee or agent of the Contractor to provide a gift to any such public official or state employee; and
5. The Contractor made the bid/proposal for the Agreement without fraud or collusion with any person;
6. The information set forth herein is true, to the best of my knowledge and belief, subject to the penalties of false statement.

**TABLE 2: CRRA Substantial Participants in the Preparation of the Request for Bids/Proposals for the Agreement**

Richard Quelle, Senior Engineer
Michael Tracey, Operations Manager, Construction Management

**TABLE 3: Public Officials and State Employees of State Agencies Who Have Supervisory or Appointing Authority over CRRA**

Governor M. Jodi Rell
Senator Donald E. Williams, Jr., President Pro Tempore of the Senate
Senator John McKinney, Minority Leader of the Senate
Representative James A. Amann, Speaker of the House of Representatives
Representative Lawrence F. Cafero, Jr., Minority Leader of the House of Representatives

Signature: \_\_\_\_\_

Name (type/print): \_\_\_\_\_

Title: \_\_\_\_\_

State Of: \_\_\_\_\_

County Of: \_\_\_\_\_

\_\_\_\_\_, being fully sworn, deposes and says that he/she is the \_\_\_\_\_ (Title) of \_\_\_\_\_ (Firm Name), the Contractor herein, that he/she has read the foregoing statement concerning gifts, and, under the penalty of perjury, certifies that each and every part of said statement is true to his/her best knowledge and belief.

Sworn to before me this \_\_\_\_\_ day of \_\_\_\_\_ 200\_\_

\_\_\_\_\_  
Notary Public/Commissioner of the Superior Court

For the purposes of this Certification Concerning Gifts, the following terms are defined as follows:

"Gift" means anything of value, which is directly and personally received, unless consideration of equal or greater value is given in return. "Gift" shall not include:

- (1) A political contribution otherwise reported as required by law or a donation or payment as described in subdivision (9) or (10) of subsection (b) of section 9-333b of the *Connecticut General Statutes*;
- (2) Services provided by persons volunteering their time, if provided to aid or promote the success or defeat of any political party, any candidate or candidates for public office or the position of convention delegate or town committee member or any referendum question;
- (3) A commercially reasonable loan made on terms not more favorable than loans made in the ordinary course of business;
- (4) A gift received from (A) an individual's spouse, fiancé or fiancée, (B) the parent, brother or sister of such spouse or such individual, or (C) the child of such individual or the spouse of such child;
- (5) Goods or services (A) which are provided to the state (i) for use on state property, or (ii) to support an event or the participation by a public official or state employee at an event, and (B) which facilitate state action or functions. As used in this Affidavit Concerning Gifts, "state property" means (i) property owned by the state, or (ii) property leased to an agency in the Executive or Judicial Department of the state;
- (6) A certificate, plaque or other ceremonial award costing less than one hundred dollars;
- (7) A rebate, discount or promotional item available to the general public;
- (8) Printed or recorded informational material germane to state action or functions;
- (9) Food or beverage or both, costing less than fifty dollars in the aggregate per recipient in a calendar year, and consumed on an occasion or occasions at which the person paying, directly or indirectly, for the food or beverage, or his representative, is in attendance;
- (10) Food or beverage or both, costing less than fifty dollars per person and consumed at a publicly noticed legislative reception to which all members of the General Assembly are invited and which is hosted not more than once in any calendar year by a lobbyist or business organization. For the purposes of such limit, (A) a reception hosted by a lobbyist who is an individual shall be deemed to have also been hosted by the business organization which he owns or is employed by, and (B) a reception hosted by a business organization shall be deemed to have also been hosted by all owners and employees of the business organization who are lobbyists. In making the calculation for the purposes of such fifty-dollar limit, the donor shall divide the amount spent on food and beverage by the number of persons whom the donor reasonably expects to attend the reception;
- (11) Food or beverage or both, costing less than fifty dollars per person and consumed at a publicly noticed reception to which all members of the General Assembly from a region of the state are

invited and which is hosted not more than once in any calendar year by a lobbyist or business organization. For the purposes of such limit, (A) a reception hosted by a lobbyist who is an individual shall be deemed to have also been hosted by the business organization which he owns or is employed by, and (B) a reception hosted by a business organization shall be deemed to have also been hosted by all owners and employees of the business organization who are lobbyists. In making the calculation for the purposes of such fifty-dollar limit, the donor shall divide the amount spent on food and beverage by the number of persons whom the donor reasonably expects to attend the reception. As used in this subdivision, "region of the state" means the established geographic service area of the organization hosting the reception;

- (12) Gifts costing less than one hundred dollars in the aggregate or food or beverage provided at a hospitality suite at a meeting or conference of an interstate legislative association, by a person who is not a registrant or is not doing business with the state of Connecticut;
- (13) Admission to a charitable or civic event, including food and beverage provided at such event, but excluding lodging or travel expenses, at which a public official or state employee participates in his official capacity, provided such admission is provided by the primary sponsoring entity;
- (14) Anything of value provided by an employer of (A) a public official, (B) a state employee, or (C) a spouse of a public official or state employee, to such official, employee or spouse, provided such benefits are customarily and ordinarily provided to others in similar circumstances; or
- (15) Anything having a value of not more than ten dollars, provided the aggregate value of all things provided by a donor to a recipient under this subdivision in any calendar year shall not exceed fifty dollars.

"Participated substantially" means participation that is direct, extensive and substantive, and not peripheral, clerical or ministerial.

"Principals and key personnel" means officers, directors, shareholders, members, partners and managerial employees.



**REQUEST FOR BIDS  
FOR  
REFURBISHMENT OF  
PRIMARY SHREDDERS CV-104/204 AT THE  
MID-CONNECTICUT WASTE PROCESSING FACILITY**

**SECTION 14  
NOTICE TO PROCEED**



**NOTICE TO PROCEED**

**TO:** [NAME OF SUCCESSFUL BIDDER]  
[ADDRESS OF SUCCESSFUL BIDDER]

**PROJECT:** Mid-Connecticut

**CONTRACT NO.:** [TO BE ADDED LATER BY CRRA]

**CONTRACT:** Refurbishment Of Primary Shredders CV-104/204 At The Mid-Connecticut Waste Processing Facility

You are hereby notified to commence the Work related to refurbishing Primary Shredders CV-104/204 in accordance with the Agreement, dated [DATE OF AGREEMENT], and that the Contract Time under the Agreement will commence to run on [DATE CONTRACT TIME STARTS]. By this date, you are to start performing the Work required by the Contract Documents. Pursuant to the Agreement, the date for completing all of the Work related to refurbishing the Primary Shredders CV-104/204 and having such Work ready for CRRA's acceptance is as follows:

Completion Date: [COMPLETION DATE]

You are required to acknowledge your receipt of this Notice To Proceed by signing below and returning such receipted Notice To Proceed to CRRA.

Dated this [DAY] day of [MONTH], [YEAR].

Connecticut Resources Recovery Authority

By: \_\_\_\_\_  
[NAME OF CRRA OFFICIAL]  
Title: [TITLE OF CRRA OFFICIAL]

**ACCEPTANCE OF NOTICE**

Receipt of this NOTICE TO PROCEED is hereby acknowledged this \_\_\_\_\_ day of \_\_\_\_\_, 200\_.

By:

Signature: \_\_\_\_\_

Name (print/type): \_\_\_\_\_

Title: \_\_\_\_\_

**REQUEST FOR BIDS  
FOR  
REFURBISHMENT OF  
PRIMARY SHREDDERS CV-104/204 AT THE  
MID-CONNECTICUT WASTE PROCESSING FACILITY**

**SECTION 15**

**REFURBISHMENT OF PRIMARY SHREDDERS  
CV-104/204 AT THE MID-CONNECTICUT WASTE  
PROCESSING FACILITY AGREEMENT**

**REFURBISHMENT OF PRIMARY SHREDDERS CV-104/204  
AT THE  
MID-CONNECTICUT WASTE PROCESSING FACILITY  
AGREEMENT**

**CONTENTS**

PRELIMINARY STATEMENT ..... 3

1. DEFINITIONS, CONSTRUCTION AND INTERPRETATION..... 3

    1.1 Definitions ..... 3

    1.2 Construction And Interpretation ..... 4

2. SCOPE OF WORK ..... 5

    2.1 Contractor’s Responsibilities..... 5

    2.2 Performance and Completion of Work..... 5

    2.3 CRRA’s Responsibilities..... 6

    2.4 Direction of Work..... 6

    2.5 CRRA’s Inspection Rights ..... 6

    2.6 Access ..... 7

    2.7 Change in Scope of Work..... 7

    2.8 Site and Subsurface Conditions ..... 7

    2.9 Proprietary Information ..... 8

    2.10 Books and Records ..... 8

    2.11 Status of Contractor ..... 8

    2.12 Subcontractors ..... 9

    2.13 Contractor’s Employees..... 9

    2.14 Mechanic’s Liens..... 9

3. COMPENSATION AND PAYMENT ..... 10

    3.1 Compensation ..... 10

    3.2 Payment Procedure ..... 10

    3.3 Accounting Obligations ..... 10

    3.4 Withholding Taxes And Other Payments ..... 10

    3.5 State of Connecticut Taxes ..... 11

4. TERM OF AGREEMENT ..... 11

    4.1 Term ..... 11

    4.2 Time is of the Essence ..... 11

    4.3 Termination ..... 12

    4.4 Restoration..... 12

5. INDEMNIFICATION ..... 13

    5.1 Contractor’s Indemnity..... 13

    5.2 Workmanship and Materials Warranty; Other Warranties and Guarantees ..... 13

6. INSURANCE ..... 14

6.1	Required Insurance .....	14
6.2	Certificates.....	14
6.3	Specific Requirements.....	15
6.4	Issuing Companies.....	15
6.5	Contractor’s Subcontractors .....	15
6.6	No Limitation on Liability.....	15
6.7	Other Conditions .....	15
7.	<b>SECURITY FOR FAITHFUL PERFORMANCE .....</b>	<b>16</b>
7.1	Required Security .....	16
7.2	Submission Of Security.....	16
7.3	Specific Requirements – Performance Bond and Payment Bond.....	16
7.4	Specific Requirements – Letter Of Credit .....	16
7.5	Failure To Maintain The Security.....	17
7.6	Exercise Of Rights And Remedies .....	17
7.7	Issuing Companies.....	17
8.	<b>MISCELLANEOUS .....</b>	<b>17</b>
8.1	Non-Discrimination.....	17
8.2	Entire Agreement.....	18
8.3	Governing Law .....	18
8.4	Assignment .....	18
8.5	No Waiver .....	18
8.6	Modification .....	19
8.7	Prevailing Wages.....	19
8.8	Campaign Contribution And Solicitation Prohibitions .....	19
8.9	Notices.....	20
8.10	Benefit and Burden.....	20
8.11	Severability.....	20
8.12	Counterparts .....	21
	EXHIBIT A – Parts And Labor Specifications .....	A-1
	EXHIBIT B – Drawings .....	B-1
	EXHIBIT C – Project Schedule.....	C-1
	EXHIBIT D – Performance Bond Form and Letter Of Credit Form.....	D-1
	EXHIBIT E – Payment Bond.....	E-1
	EXHIBIT F – Prevailing Wage Bid Package .....	F-1
	EXHIBIT G – Schedule Of Prevailing Wages .....	G-1
	EXHIBIT H – SEEC Form 11, Notice To Executive Branch State Contractors And Prospective State Contractors Of Campaign Contribution And Solicitation Ban.....	H-1

**THIS REFURBISHMENT OF PRIMARY SHREDDERS CV-104/204 AT THE MID-CONNECTICUT WASTE PROCESSING FACILITY AGREEMENT** (“Agreement”) is made and entered into as of this [DAY] day of [MONTH], [YEAR] by and between the **CONNECTICUT RESOURCES RECOVERY AUTHORITY**, a body politic and corporate, constituting a public instrumentality and political subdivision of the State of Connecticut, having its principal offices at 100 Constitution Plaza, 6<sup>th</sup> Floor, Hartford, Connecticut 06103 (hereinafter “CRRA” or “Owner”) and [NAME OF CONTRACTOR], having its principal offices at [ADDRESS OF CONTRACTOR] (hereinafter “Contractor”).

## **PRELIMINARY STATEMENT**

**WHEREAS** CRRA owns a certain parcel of real property located at 300 Maxim Road, Gate 70, in Hartford, Connecticut (the “Property”), upon which property CRRA operates the Mid-Connecticut Waste Processing Facility (the “Facility”).

**WHEREAS** CRRA now desires to enter into this Agreement with Contractor in order for Contractor to refurbish primary shredders CV-104/204 at the Facility within the boundaries of the Property, and other related work, in accordance with the Contract Documents (the “Project”).

**NOW, THEREFORE**, in consideration of the mutual covenants, promises, and representations contained herein, and for other good and valuable consideration, the receipt and sufficiency of which are hereby acknowledged, the parties hereto agree as follows.

## **1. DEFINITIONS, CONSTRUCTION AND INTERPRETATION**

### **1.1 Definitions**

As used in this Agreement and in other Contract Documents (as defined herein) the following terms shall have the meanings as set forth below:

- (a) “**Addenda**” means written or graphic documents issued prior to the bid due date, which clarify, correct or change any or all of the Contract Documents.
- (b) “**Acceptance Date**” means the date on which CRRA determines that the Work (as defined herein) has been completed by Contractor in accordance with the Contract Documents.
- (c) “**Contract Documents**” means this Agreement (including all exhibits attached hereto), Notice To Contractors - Invitation To Bid, Instructions To Bidders, Addenda, Contractor’s bid (including all documentation accompanying such bid, all other documentation submitted in connection with such bid, and all post-bid documentation submitted prior to the Notice Of Award), Notice Of Award, the Notice To Proceed (as defined herein), the Bonds (as defined herein), the Plans

(as defined herein), any written amendments to any of the Contract Documents and any change order issued pursuant to Section 2.7 and/or 8.6 hereof.

- (d) **“Contract Time”** means the number of days or the date, as set forth in **Exhibit C** of this Agreement, to perform and complete the Work and have such Work ready for CRRA’s acceptance.
- (e) **“Effective Date”** means the date set forth above in this Agreement.
- (f) **“Engineer”** means a dully authorized agent of CRRA.
- (g) **“Laws And Regulations”** means any and all applicable current or future laws, rules, regulations, ordinances, codes, orders and permits of any and all federal, state and local governmental and quasi-governmental bodies, agencies, authorities and courts having jurisdiction.
- (h) **“Notice Of Award”** means written notification from CRRA to the apparent successful bidder which states that CRRA has accepted such bidder’s bid and sets forth the remaining conditions that must be fulfilled by such bidder before CRRA executes the Agreement.
- (i) **“Owner”** means CRRA.
- (j) **“Owner’s Designee”** or **“Owner’s Representative”** means Engineer.
- (k) **“Site”** means those areas of the Property upon which the Work is to be performed, furnished and completed by Contractor in accordance with the Contract Documents.

## 1.2 Construction And Interpretation

For purposes of this Agreement:

- (a) Capitalized terms used herein shall have the meanings set forth herein;
- (b) Whenever nouns or pronouns are used in this Agreement, the singular shall mean the plural, the plural shall mean the singular, and any gender shall mean all genders or any other gender, as the context may require;
- (c) Words that have well-known technical or trade meanings are used herein in accordance with such recognized meanings unless otherwise specifically provided;
- (d) All accounting terms not otherwise defined herein have the meanings assigned to them in accordance with “generally accepted accounting principles,” and the term “generally accepted accounting principles” with respect to any computation required or permitted hereunder shall mean such accounting principles that are generally accepted as of the Effective Date of this Agreement;



- (e) The words “herein”, “hereof” and “hereunder” and words of similar import refer to this Agreement as a whole and not to any particular Article, Section or Sub-section;
- (f) Reference to any particular party shall include that party’s employees and the authorized agents of that party;
- (g) All references to agreements are references to the agreements as the provisions thereof that may be amended, modified or waived from time to time; and,
- (h) The captions contained in this Agreement have been inserted for convenience only and shall not affect or be effective to interpret, change or restrict the terms of provisions of this Agreement.

## **2. SCOPE OF WORK**

### **2.1 Contractor’s Responsibilities**

Contractor shall be responsible for:

- (a) Preparing engineering drawings of various parts for Primary Shredders CV-104/204, fabricating the parts and installing the parts at the Facility;
- (b) Performing all other work required for the Project, all of which is in accordance with and as required by the Contract Documents, including but not limited to, the parts and labor specifications set forth in **Exhibit A** attached hereto and made a part hereof (the “Parts And Labor Specifications”) and the drawings set forth in **Exhibit B** attached hereto and made a part hereof (the “Drawings”);
- (c) Furnishing all labor, materials, supplies, tools, equipment and other facilities and necessary appurtenances or property for or incidental to the Project and the performance and completion of the Work (as hereinafter defined);
- (d) Restoring any part of the Property, the improvements thereon, including but not limited to any access roads, or the Work (as hereinafter defined) that require restoration pursuant to the terms and conditions in Section 4.4 hereof; and
- (e) Making all required notifications and obtaining all local, state, and federal permits and approvals necessary for the completion of the Work.

Items (a) through (e) above are hereinafter collectively referred to as the “Work.”

### **2.2 Performance and Completion of Work**

All Work shall be performed and completed by Contractor in a good workmanlike manner consistent and in accordance with:

- (a) Any and all instructions, guidance and directions provided by CRRA or Engineer to Contractor;
- (f) The Contract Documents;
- (g) Sound practices for providing and installation of parts for conveyor systems;
- (h) The highest industry standards applicable to Contractor and its performance of the Work hereunder;
- (i) The schedule for the Work set forth in **Exhibit C** attached hereto and made a part hereof; and
- (j) All Laws And Regulations.

Items (a) through (f) above are hereinafter collectively referred to as the “Standards.”

Contractor shall obtain any locally required building or other permits required for the Work, and Contractor shall also assist and fully cooperate with CRRA in obtaining any other applicable permits necessary to begin and complete the Work.

### **2.3 CRRA's Responsibilities**

CRRA and/or its Engineer shall be responsible for administering this Agreement, accepting the Work that is performed and completed by Contractor in accordance with the Contract Documents, and receiving and paying invoices for such Work.

### **2.4 Direction of Work**

CRRA and/or its Engineer may, where necessary or desired, provide Contractor with instructions, guidance and directions in connection with Contractor's performance of the Work hereunder. CRRA reserves the right to determine whether Contractor will, upon completion of any phase of the Work, proceed to any or all remaining phases of the Work. If CRRA determines that Contractor shall not proceed with the remaining Work, CRRA shall terminate this Agreement in accordance with Section 4.3 hereof.

### **2.5 CRRA's Inspection Rights**

Contractor's performance of the Work hereunder, as well as Contractor's work products resulting from such performance, are subject to inspection by CRRA. Inspections may be conducted at any time by CRRA. In the event of an inspection, Contractor shall provide to CRRA any documents or other materials that may be necessary in order for CRRA to conduct the inspection. If, after any such inspection, CRRA is unsatisfied with Contractor's performance of the Work hereunder or any of the work products resulting therefrom, Contractor shall, at the direction of CRRA, render such performance or work products satisfactory to CRRA at no additional cost or expense to CRRA and without any extension of or addition to

any Contract Time for the remaining Work. For purpose of this Section 2.5, CRRA shall mean CRRA and/or its authorized agents, including but not limited to Engineer.

## **2.6 Access**

CRRA hereby grants to Contractor, during such times as directed by CRRA and/or its Engineer, access to only those areas of the Property necessary for Contractor to perform the Work hereunder, provided that:

- (a) Contractor shall not interfere with any other operations or activities being conducted on the Property by either CRRA or any other person or entity;
- (k) Contractor directly coordinates with CRRA and/or its Engineer on such access and Contractor's storage of any equipment or materials on the Property; and
- (l) Contractor is in compliance with all of the terms and conditions of this Agreement.

CRRA reserves the right to revoke the access granted to Contractor herein if Contractor fails to comply with any of the foregoing conditions of access.

## **2.7 Change in Scope of Work**

In the event that CRRA determines during the term of this Agreement that any revisions, modifications or changes are necessary to the scope of Work as set forth in Section 2.1 hereof, then pursuant to CRRA's request, Contractor shall promptly commence and perform the work required for such revisions, modifications or changes, which work shall be performed in accordance with the Standards unless otherwise specifically agreed to in writing by CRRA and Contractor. If any adjustment(s) to the Contract Price and/or the Contract Time is required as a result of such revisions, modifications or changes, CRRA and Contractor shall mutually agree in writing on the amount of such adjustment(s) provided that the schedule of values (including the unit prices set forth therein) approved by CRRA for the Project, to the extent applicable, shall be used to determine the appropriate increase or decrease in the quantity or cost of the materials or Work necessitated by such revisions, modifications or changes. Contractor shall promptly commence and perform any work required by such revisions, modifications or changes even if CRRA and Contractor cannot agree on the amount of such adjustment(s).

## **2.8 Site and Subsurface Conditions**

All information and data shown or indicated in the Contract Documents with respect to underground facilities, surface conditions, subsurface conditions or other conditions at or contiguous to the Site are furnished for information only and CRRA does not assume any responsibility for the accuracy or completeness of such information and data. Contractor acknowledges and agrees that CRRA does not assume any responsibility for such information and data and that Contractor is solely responsible for investigating and satisfying itself as to all actual and existing Site conditions, including but not limited to surface conditions, subsur-

face conditions and underground facilities. Contractor has carefully studied all such information and data and Contractor has obtained and carefully studied (or assumes responsibility for having done so) all such additional or supplementary examinations, investigations, explorations, tests, studies and data concerning conditions (including but not limited to surface conditions, subsurface conditions and underground facilities) at or contiguous to the Site and all other conditions or factors which may affect cost, progress, performance, furnishing or completion of the Work or which relate to any aspect of the means, methods, techniques, sequences, and procedures of construction or performance of the Work to be employed by Contractor and safety precautions and programs incident thereto. Contractor does not consider that any additional examinations, investigations, explorations, tests, studies or data are necessary for Contractor to conclusively determine, and Contractor has so determined, that the Work can be performed, furnished and completed in accordance with the Contract Time, the Contract Price and the other terms and conditions of the Contract Documents. In the event that the information or data shown or indicated in the Contract Documents with respect to underground facilities or surface, subsurface or other conditions at or contiguous to the Site differs from conditions encountered by Contractor during performance of the Work, there shall be no increase in the Contract Price and/or no extension of the Contract Time as a result of such differing conditions, unless CRRA, in its sole and absolute discretion, agrees in writing to such increase and/or extension.

## **2.9 Proprietary Information**

Contractor shall not use, publish, distribute, sell or divulge any information obtained from CRRA by virtue of this Agreement for Contractor's own purposes or for the benefit of any person, firm, corporation or other entity (other than CRRA) without the prior written consent of CRRA. Any report or other work product prepared by Contractor in connection with the performance of the Work hereunder shall be owned solely and exclusively by CRRA and cannot be used by Contractor for any purpose beyond the scope of this Agreement without the prior written consent of CRRA.

## **2.10 Books and Records**

Contractor shall maintain proper books and records containing complete and correct information on all Work performed by Contractor pursuant to this Agreement in accordance with generally accepted accounting principles and practices. CRRA has the right to inspect and review all such books and records during Contractor's business hours.

## **2.11 Status of Contractor**

CRRA and Contractor acknowledge and agree that Contractor is acting as an independent contractor in performing any Work for CRRA hereunder and that Contractor shall perform such Work in its own manner and method subject to the terms of this Agreement. Nothing in this Agreement shall be construed or interpreted as creating a partnership, a joint venture, an agency, a master-servant relationship, an employer-employee relationship or any other relationship between CRRA and Contractor other than that of an owner and an independent contractor. Contractor is expressly forbidden from transacting any business in the name of or on

account of CRRA, and Contractor has no power or authority to assume or create any obligation or responsibility for or on behalf of CRRA in any manner whatsoever.

## **2.12 Subcontractors**

Contractor shall consult with CRRA before hiring any subcontractors to perform any Work hereunder. Contractor shall require all of its subcontractors to abide by the terms and conditions of this Agreement. Moreover, Contractor's subcontracts with such subcontractors shall specifically provide that, in the event of a default by Contractor thereunder or under this Agreement, CRRA may directly enforce such subcontracts and make payments thereunder. Contractor shall provide CRRA with all contracts, amendments, books, records, accounts, correspondence and other materials necessary to enforce such subcontracts. Also Contractor's subcontracts with its subcontractors shall specifically include CRRA as a third party beneficiary and shall provide that such subcontractors shall not be excused from any of their obligations under such subcontracts by reason of any claims, setoffs, or other rights whatsoever that they may have with or against Contractor other than through such subcontracts.

## **2.13 Contractor's Employees**

All persons employed by Contractor shall be subject and responsible solely to the direction of Contractor and shall not be deemed to be employees of CRRA.

## **2.14 Mechanic's Liens**

Contractor shall claim no interest in the Property or any equipment, fixtures or improvements located or to be located thereon, including but not limited to the Site or any part thereof. Contractor shall not file any mechanic's liens or other liens or security interests against CRRA or any of its properties, including but not limited to the Property. Contractor shall defend, indemnify and hold harmless CRRA against all costs associated with the filing of such liens or interests by Contractor or any of its subcontractors or materialmen. Before any subcontractor or materialman of Contractor commences any Work hereunder, Contractor shall deliver to CRRA an original waiver of mechanic's liens properly executed by such subcontractor or materialman. If any mechanic's lien is filed against CRRA or any of its properties in connection with the Work hereunder, Contractor shall cause the same to be canceled and discharged of record within fifteen (15) days after the filing of such lien and, if Contractor fails to do so, CRRA may, at its option but without any obligation to do so, make any payment necessary to obtain such cancellation or discharge and the cost thereof, at CRRA's election, shall be either deducted from any payment due to Contractor hereunder or reimbursed to CRRA promptly upon demand by CRRA to Contractor.

### **3. COMPENSATION AND PAYMENT**

#### **3.1 Compensation**

The total amount of compensation to be paid to Contractor by CRRA for the Work hereunder shall not exceed [AMOUNT OF CONTRACT] Dollars ([\$NUMBER]) (the "Contract Price"), which Contract Price shall be payable as set forth in Section 3.2 below. Contractor acknowledges and agrees that the Contract Price constitutes the full compensation to Contractor for the Work to be performed by Contractor hereunder and includes all expenses and costs to be incurred by Contractor in performing such Work.

#### **3.2 Payment Procedure**

After Contractor completes the Work, except for the one (1) year warranty period, Contractor shall submit to CRRA a written request for payment for all the Work completed by Contractor. The written request for payment shall be submitted in accordance with the General Requirements, and such request shall include the name of the Project, the contract number, and all of the other information and documentation required by the General Requirements.

If CRRA determines in its sole and absolute discretion that the Work for which Contractor is requesting payment has been properly performed and completed in conformance with the Standards, Contractor is not in default hereunder and CRRA does not dispute the amount of the payment requested, then CRRA shall pay Contractor the amount requested (the "Authorized Sum") within thirty (30) days after CRRA's receipt of such written request. If, however, CRRA determines that any of the Work for which Contractor has requested payment is not in conformance with the Standards, then CRRA may in its sole and absolute discretion withhold all or a portion of the Authorized Sum, and Contractor shall, if requested by CRRA, immediately take, at Contractor's sole cost and expense, all action necessary to render such Work in conformance with the Standards. CRRA shall have no obligation under this Agreement to pay for any Work that CRRA determines has not been performed and/or completed in conformance with the Standards. CRRA shall have no obligation to pay Contractor any amounts due Contractor under this Agreement if Contractor is in default hereunder.

#### **3.3 Accounting Obligations**

Contractor shall maintain books and accounts of the costs incurred by Contractor in performing the Work pursuant to this Agreement by contract number and in accordance with generally accepted accounting principles and practices. CRRA, during normal business hours, for the duration of this Agreement, shall have access to such books and accounts to the extent required to verify such costs incurred.

#### **3.4 Withholding Taxes And Other Payments**

No FICA (social security) payroll tax, state or federal income tax, federal unemployment tax or insurance payments, state disability tax or insurance payments or state unemployment tax or insurance payments shall be paid or deposited by CRRA with respect to Contractor, nor be withheld from payment to Contractor by CRRA. No workers' compensation insurance has

been or will be obtained by CRRA on account of the Work to be performed hereunder by Contractor, or any of Contractor's employees or subcontractors. Contractor shall be responsible for paying or providing for all of the taxes, insurance and other payments described or similar to those described in this Section 3.4 and Contractor hereby agrees to indemnify CRRA and hold CRRA harmless against any and all such taxes, insurance or payments, or similar costs which CRRA may be required to pay in the event that Contractor's status hereunder is determined to be other than that of an independent contractor.

### **3.5 State of Connecticut Taxes**

Contractor agrees that, pursuant to *Connecticut General Statutes* § 22a-270 (as the same may be amended or superceded from time to time) CRRA is exempt from all State of Connecticut taxes and assessments. Without limiting the generality of the preceding sentence, Contractor also agrees that, pursuant to *Connecticut General Statutes* § 12-412(92) (as the same may be amended or superceded from time to time), "[t]he sales and use of any services or tangible personal property to be incorporated into or used or otherwise consumed in the operation of any project of [CRRA] . . . whether such purchases are made directly by [CRRA] or are reimbursed by [CRRA] to the lessee or operator of such project" is not subject to Connecticut Sales and Use Taxes. Accordingly, Contractor shall not charge CRRA any State of Connecticut taxes or assessments at any time in connection with Contractor's performance of this Agreement, nor shall Contractor include any State of Connecticut taxes or assessments in any rates, costs, prices or other charges to CRRA hereunder. The obligations of Contractor contained in the preceding sentence are absolute and shall apply notwithstanding any payment by Contractor of any State of Connecticut taxes or assessments in connection with its performance of this Agreement. Contractor represents and warrants that no State of Connecticut taxes or assessments were included in any rates, costs, prices or other charges presented to CRRA in any RFB or other submittal or proposal to CRRA in connection with this Agreement.

## **4. TERM OF AGREEMENT**

### **4.1 Term**

The term of this Agreement shall commence upon the Effective Date and shall terminate, unless otherwise terminated or extended in accordance with the terms and provisions hereof, on the first anniversary of the Acceptance Date.

### **4.2 Time is of the Essence**

CRRA and Contractor hereby acknowledge and agree that time is of the essence with respect to Contractor's performance of the Work hereunder. Accordingly, upon CRRA's issuance to Contractor of a notice to proceed with the Work (the "Notice To Proceed"), which Notice To Proceed shall be issued after the parties hereto receive all of the local, state and federal permits required for the Work hereunder, Contractor shall immediately commence performance of the Work and continue to perform the same during the term of this Agreement in accor-

dance with the schedule set forth in attached **Exhibit C** in order to complete all of the Work and have such Work ready for CRRA's acceptance at the end of the number of days specified in **Exhibit C** following the issuance of such Notice To Proceed (the "Completion Date").

CRRA and Contractor recognize the difficulties involved in proving actual damages and losses suffered by CRRA if the Work is not completed and ready for CRRA's acceptance by the Completion Date. Accordingly, instead of requiring any such proof, CRRA and Contractor agree that as liquidated damages for any such delay in completion or readiness for acceptance (but not as a penalty) Contractor shall pay CRRA one hundred dollars (\$100.00) for each calendar day beyond the Completion Date that Contractor fails to complete all of the Work or have the same ready for CRRA's acceptance until all such Work is completed by Contractor and readied by Contractor for acceptance by CRRA.

### **4.3 Termination**

CRRA may terminate this Agreement at any time by providing Contractor with ten (10) days' prior written notice of such termination. Upon receipt of such written notice from CRRA, Contractor shall immediately cease performance of all Work, unless otherwise directed in writing by CRRA. Prior to any termination of this Agreement, Contractor shall remove all of its personnel and equipment from the Property, restore any part of the Property, any of the improvements located or to be located thereon, including but not limited to any access roads, or any of the Work that requires restoration pursuant to the terms and conditions of Section 4.4 hereof. Upon termination of this Agreement pursuant to this Section 4.3,

- (a) CRRA shall pay Contractor for all Work performed and completed by Contractor prior to the termination date, provided:
  - (1) Such Work has been performed and completed by Contractor in conformance with the Standards;
  - (2) Payment for such Work has not been previously made or is not disputed by CRRA;
  - (3) Contractor is not in default hereunder; and,
  - (4) Contractor has performed and completed all its obligations under this Section 4.3 and Section 4.4 hereof to CRRA's satisfaction, and
- (m) CRRA shall have no further liability hereunder.

Except for the payment that may be required pursuant to the preceding sentence, CRRA shall not be liable to Contractor in any other manner whatsoever in the event CRRA exercises its right to terminate this Agreement.

### **4.4 Restoration**

Unless otherwise directed in writing by CRRA, Contractor shall:



- (a) Restore any part of the Property or any of the improvements located or to be located thereon, other than those areas of the Property or such improvements improved by Contractor pursuant to this Agreement, disturbed or damaged by Contractor or any of its directors, officers, employees, agents, subcontractors or materialmen to the same condition existing immediately prior to such disturbance or damage; and
- (n) Restore or repair any completed Work so disturbed or damaged to the condition required by the Contract Documents for acceptance of such Work by CRRA.

## **5. INDEMNIFICATION**

### **5.1 Contractor's Indemnity**

Contractor shall at all times defend, indemnify and hold harmless CRRA and its board of directors, officers, agents and employees from and against any and all claims, damages, losses, judgments, liability, workers' compensation payments and expenses (including but not limited to attorneys' fees) arising out of injuries to the person (including death), damage to property or any other damages alleged to have been sustained by: (a) CRRA or any of its directors, officers, agents, employees or other contractors, or (b) Contractor or any of its directors, officers, agents, employees, subcontractors or materialmen, or (c) any other person, to the extent any such injuries, damage or damages are caused or alleged to have been caused in whole or in part by the acts, omissions or negligence of Contractor or any of its directors, officers, agents, employees, subcontractors or materialmen. Contractor further undertakes to reimburse CRRA for damage to property of CRRA caused by Contractor or any of its directors, officers, agents, employees, subcontractors or materialmen, or by faulty, defective or unsuitable material or equipment used by it or any of them. The existence of insurance shall in no way limit the scope of this indemnification. Contractor's obligations under this Section 5.1 shall survive the termination or expiration of this Agreement.

### **5.2 Workmanship and Materials Warranty; Other Warranties and Guarantees**

For a period of one (1) year following the Acceptance Date (the "Warranty Period"), Contractor warrants the workmanship, equipment, and materials furnished under this Agreement for the Project against defects. If during or at the end of the Warranty Period, CRRA determines that any of such workmanship, equipment or materials is or has become defective, Contractor shall, at its own cost and expense, promptly repair or replace such defective workmanship, equipment or materials in order to render the same to the same condition as warranted above. Any repairs to or replacements of such workmanship, equipment or materials required under this Section 5.2 must be approved by CRRA before Contractor may commence performance of such repairs or replacements, and all such repairs or replacements shall be performed by Contractor in accordance with all applicable Standards. In connection therewith Contractor shall obtain all warranties and guarantees for all material and equipment furnished hereunder by Contractor that are assignable to CRRA. Contractor shall assign such

warranties and guarantees to CRRA upon the Acceptance Date. Contractor's obligations under this Section 5.2 shall survive the termination or expiration of this Agreement.

## **6. INSURANCE**

### **6.1 Required Insurance**

Contractor shall procure and maintain, at its own cost and expense, throughout the term of this Agreement and any extension thereof, the following insurance, including any required endorsements thereto and amendments thereof:

- (a) Commercial General Liability insurance alone or in combination with Commercial Umbrella insurance with a limit of not less than three million dollars (\$3,000,000) each occurrence covering liability arising from premises, operations, independent contractors, products-completed operations, personal injury and advertising injury, and liability assumed under an insurance contract (including the tort liability of another assumed in a business contract).
- (b) Business Automobile Liability insurance alone or in combination with Commercial Umbrella insurance covering any auto (including owned, hired, and non-owned autos), with a limit of not less than one million dollars (\$1,000,000) each accident.
- (c) Workers' Compensation with statutory limits and Employers' Liability limits of not less than five hundred thousand dollars (\$500,000) each accident for bodily injury by accident or five hundred thousand dollars (\$500,000) for each employee for bodily injury by disease.
- (d) Product Liability insurance with a limit of one million dollars (\$1,000,000). The policy shall remain in effect for period of one (1) year following delivery of the finished product.
- (e) Contractor's Property and Equipment insurance covering one hundred percent (100%) of the actual cash value of all equipment owned and/or leased for or by Contractor for this Project.

### **6.2 Certificates**

Within five (5) days after CRRA issues the Notice Of Award, and prior to commencement of activities on site, Contractor shall submit to CRRA a certificate or certificates for each required insurance referenced in Section 6.1 above certifying that such insurance is in full force and effect and setting forth the information required by Section 6.3 below. Additionally, Contractor shall furnish to CRRA within thirty (30) days before the expiration date of the coverage of each required insurance set forth in Section 6.1 above, a certificate or certificates containing the information required by Section 6.3 below and certifying that such insurance has been renewed and remains in full force and effect.

### **6.3 Specific Requirements**

All policies for each insurance required hereunder shall:

- (a) Name CRRA as an additional insured (this requirement shall not apply to workers' compensation insurance/employers' liability insurance or contractor's property and equipment insurance);
- (b) Include a standard severability of interest clause;
- (c) Provide for not less than thirty (30) days' prior written notice to CRRA by registered or certified mail of any cancellation, restrictive amendment, non-renewal or change in coverage;
- (d) Contain a waiver of subrogation holding CRRA free and harmless from all subrogation rights of the insurer; and
- (e) Provide that such required insurance hereunder is the primary insurance and that any other similar insurance that CRRA may have shall be deemed in excess of such primary insurance.

### **6.4 Issuing Companies**

All policies for each insurance required hereunder shall be issued by insurance companies that are either licensed by the State of Connecticut and have a Best's Key Rating Guide of A-VII or better, or otherwise deemed acceptable by CRRA in its sole discretion.

### **6.5 Contractor's Subcontractors**

Contractor shall either have its subcontractors covered under the insurance required hereunder, or require such subcontractors to procure and maintain the insurance that Contractor is required to procure and maintain under this Agreement.

### **6.6 No Limitation on Liability**

No provision of this Article 6 shall be construed or deemed to limit Contractor's obligations under this Agreement to pay damages or other costs and expenses.

### **6.7 Other Conditions**

CRRA shall not, because of accepting, rejecting, approving, or receiving any certificate of insurance required hereunder, incur any liability for:

- (a) The existence, non-existence, form or legal sufficiency of the insurance described on such certificate,
- (b) The solvency of any insurer, or

- (c) The payment of losses.

## **7. SECURITY FOR FAITHFUL PERFORMANCE**

### **7.1 Required Security**

Contractor shall procure and maintain in full force and effect, at its own cost and expense, throughout the term of this Agreement and any extension thereof, the following:

- (a) A performance bond or letter of credit (the “Performance Bond” or the “Letter Of Credit”) in the full amount of the Contract Price and such Performance Bond or Letter Of Credit shall be in and drawn on the forms set forth in **Exhibit D** attached hereto and made a part hereof; and
- (b) A payment bond (the “Payment Bond”) in the full amount of the Contract Price and such Construction Payment Bond shall be in and drawn on the form set forth in **Exhibit E** attached hereto and made a part hereof.

### **7.2 Submission Of Security**

Within ten (10) days after CRRA issues the Notice of Award, Contractor shall furnish CRRA with the following:

- (a) The Performance Bond or the Letter Of Credit; and
- (b) The Payment Bond.

### **7.3 Specific Requirements – Performance Bond and Payment Bond**

If the surety on the Performance Bond and/or the Payment Bond furnished by Contractor is declared a bankrupt or becomes insolvent or its right to do business is terminated in the State of Connecticut or it ceases to meet the above requirements or the surety elects not to renew the Performance Bond and/or the Payment Bond due to no fault of Contractor, Contractor shall immediately substitute another bond and surety, subject to the requirements set forth in this Article 7.

### **7.4 Specific Requirements – Letter Of Credit**

The Letter Of Credit required hereunder shall be automatically renewed by Contractor on an annual basis, unless not later than ninety (90) days prior to the then current expiration date of the Letter Of Credit, Contractor notifies CRRA by registered mail that the issuer of the Letter Of Credit elects not to renew such Letter Of Credit. If the issuer of the Letter Of Credit furnished by Contractor is declared a bankrupt or becomes insolvent or its right to do business is terminated in the State of Connecticut or it ceases to meet the above requirements or the issuer elects not to renew the Letter Of Credit due to no fault of Contractor, Contractor shall

immediately substitute another letter of credit (or bond) and surety, subject to the requirements set forth in this Section 7.

#### **7.5 Failure To Maintain The Security**

Failure to maintain or renew the Performance Bond, the Letter Of Credit and/or the Payment Bond under the aforesaid terms shall constitute a default by Contractor of this Agreement.

#### **7.6 Exercise Of Rights And Remedies**

In the event Contractor fails to perform any of its obligations under this Agreement, CRRA shall have the right, in addition to all other rights and remedies available to CRRA hereunder or otherwise, to exercise any or all of CRRA's rights and remedies under the Performance Bond, the Letter Of Credit and the Payment Bond.

#### **7.7 Issuing Companies**

The Performance Bond and the Payment Bond shall be issued and executed by a surety company or companies acceptable to CRRA. The Letter Of Credit shall be issued and executed by a Connecticut Bank or by a national banking association acceptable to CRRA.

### **8. MISCELLANEOUS**

#### **8.1 Non-Discrimination**

Contractor agrees to the following:

- (a) Contractor agrees and warrants that in the performance of the Work for CRRA Contractor will not discriminate or permit discrimination against any person or group of persons on the grounds of race, color, religious creed, age, marital status, including civil union status, national origin, ancestry, sex, sexual orientation, mental retardation or physical disability, including, but not limited to, blindness, unless it is shown by Contractor that such disability prevents performance of the Work involved, in any manner prohibited by the laws of the United States or of the State of Connecticut. Contractor further agrees to take affirmative action to insure that applicants with job related qualifications are employed and that employees are treated when employed without regard to their race, color, religious creed, age, marital status, including civil union status, national origin, ancestry, sex, sexual orientation, mental retardation, or physical disability, including, but not limited to, blindness, unless it is shown by Contractor that such disability prevents performance of the Work involved;
- (c) Contractor agrees, in all solicitations or advertisements for employees placed by or on behalf of Contractor, to state that it is an "affirmative action-equal opportunity employer" in accordance with regulations adopted by the Connecticut Commission on Human Rights and Opportunities (The "Commission");

- (d) Contractor agrees to provide each labor union or representative of workers with which Contractor has a collective bargaining agreement or other contract or understanding and each vendor with which Contractor has a contract or understanding, a notice to be provided by the Commission, advising the labor union, workers' representative and vendor of Contractor's commitments under Sections 4a-60 and 4a-60a of the *Connecticut General Statutes* and to post copies of the notice in conspicuous places available to employees and applicants for employment;
- (e) Contractor agrees to comply with each applicable provision of Sections 4a-60, 4a-60a, 46a-68e, and 46a-68f, inclusive, of the *Connecticut General Statutes* and with each regulation or relevant order issued by the Commission pursuant to Sections 46a-56, 46a-68e, and 46a-68f of the *Connecticut General Statutes*; and
- (f) Contractor agrees to provide the Commission with such information requested by the Commission, and permit access to pertinent books, records and accounts concerning the employment practices and procedures of Contractor as related to the applicable provisions of Sections 4a-60, 4a-60a and 46a-56 of the *Connecticut General Statutes*. If this Agreement is a public works contract, Contractor agrees and warrants that it will make good faith efforts to employ minority business enterprises as subcontractors and suppliers of materials in such public works project.

## **8.2 Entire Agreement**

This Agreement constitutes the entire agreement and understanding between the parties hereto and concerning the subject matter hereof, and supersedes any previous agreements, written or oral, between the parties hereto and concerning the subject matter hereof.

## **8.3 Governing Law**

This Agreement shall be governed by, and construed, interpreted and enforced in accordance with the laws of the State of Connecticut as such laws are applied to contracts between Connecticut residents entered into and to be performed entirely in Connecticut.

## **8.4 Assignment**

This Agreement may not be assigned in whole or in part by either party without the prior written consent of the other party or such assignment shall be void.

## **8.5 No Waiver**

Failure to enforce any provision of this Agreement or to require at any time performance of any provision hereof shall not be construed to be a waiver of such provision, or to affect the validity of this Agreement or the right of any party to enforce each and every provision in accordance with the terms hereof. No waiver of any provision of this Agreement shall affect the right of CRRA or Contractor thereafter to enforce such provision or to exercise any right or

remedy available to it in the event of any other default involving such provision or any other provision. Making payment or performing pursuant to this Agreement during the existence of a dispute shall not be deemed to be and shall not constitute a waiver of any claims or defenses of the party so paying or performing.

## **8.6 Modification**

This Agreement may not be amended, modified or supplemented except by a writing signed by the parties hereto that specifically refers to this Agreement. Any oral representations or letters by the parties or accommodations shall not create a pattern or practice or course of dealing contrary to the written terms of this Agreement unless this Agreement is formally amended, modified or supplemented.

## **8.7 Prevailing Wages**

Contractor hereby represents that the Contractor's Wage Certification Form, as executed by Contractor and attached hereto as part of **Exhibit F**, which Exhibit in its entirety is made a part hereof, has been submitted by Contractor to the State of Connecticut's Department of Labor for Contractor's performance of the Work. Contractor shall pay wages on an hourly basis to any mechanic, laborer or workman employed upon the Work herein and the amount of payment or contribution paid or payable on behalf of each such employee to an employee welfare fund, as defined in *Connecticut General Statutes* § 31-53(h), at rates equal to the rates customary or prevailing for the same work in the same trade or occupation in the town in which the Work is being conducted, which rates are more specifically set forth in **Exhibit G** attached hereto and made a part hereof. If Contractor is not obligated by agreement to make payment or contribution on behalf of such employees to any such employee welfare fund, Contractor shall pay to each employee as part of his or her wages the amount of payment or contribution for his or her classification on each payday. Contractor shall keep, maintain and preserve records relating to the wages and hours worked by each employee and a schedule of the occupation or work classification at which each mechanic, laborer, or workman under this Agreement is employed during each work day and week in such manner and form as the labor commissioner establishes to assure the proper payments due to such employees or employee welfare funds under *Connecticut General Statutes* §§ 31-53 and 31-54. Pursuant to *Connecticut General Statutes* § 31-53(f), Contractor shall complete and submit to CRRA on a weekly basis during the term of this Agreement and any extension thereof the payroll certification forms also set forth in **Exhibit F**. Contractor hereby represents and covenants that it is not now, and has not been for at least three (3) years previous to the date of this Agreement, listed by the labor commissioner as a person who has violated laws and regulations relating to prevailing wages.

## **8.8 Campaign Contribution And Solicitation Prohibitions**

For all State contracts as defined in P.A. 07-1 having a value in a calendar year of \$50,000 or more or a combination or series of such agreements or contracts having a value of \$100,000 or more, the authorized signatory to this Agreement expressly acknowledges receipt of the State Elections Enforcement Commission's notice advising state contractors of state cam-

paign contribution and solicitation prohibitions, and will inform its principals of the contents of the notice. See **Exhibit H** [SEEC Form 11].

**8.9 Notices**

All notices, requests, demands and other communications hereunder shall be in writing and shall be deemed to have been duly given if mailed via certified first class mail return receipt requested postage prepaid or overnight express mail service to the pertinent address below.

(a) If to CRRA:

Connecticut Resources Recovery Authority  
100 Constitution Plaza, 6<sup>th</sup> Floor  
Hartford, Connecticut 06103  
Attention: Richard Quelle

With a copy to:

Connecticut Resources Recovery Authority  
100 Constitution Plaza, 6<sup>th</sup> Floor  
Hartford, Connecticut 06103  
Attention: President

(g) If to Contractor:

\_\_\_\_\_  
\_\_\_\_\_  
\_\_\_\_\_  
Attention: \_\_\_\_\_

**8.10 Benefit and Burden**

This Agreement shall inure to the benefit of and be binding upon the heirs, personal representatives, successors and assigns of the parties hereto.

**8.11 Severability**

CRRA and Contractor hereby understand and agree that if any part, term or provision of this Agreement is held by any court to be invalid, illegal or in conflict with any applicable law, the validity of the remaining portions of this Agreement shall not be affected, and the rights and obligations of the parties shall be construed and enforced as if this Agreement did not contain the particular part, term or provision held to be invalid, illegal or in conflict with any applicable law.



**8.12 Counterparts**

This Agreement may be executed in any number of counterparts by the parties hereto. Each such counterpart so executed shall be deemed to be an original and all such executed counterparts shall constitute but one and the same instrument.

**IN WITNESS WHEREOF**, the parties hereto have set their hands and seals as of the day and year first written above.

CONNECTICUT RESOURCES RECOVERY AUTHORITY

By: \_\_\_\_\_  
Thomas D. Kirk  
Its President  
Duly Authorized

CONTRACTOR

By: \_\_\_\_\_  
Its  
Duly Authorized

**EXHIBIT A**

To

**REFURBISHMENT OF  
PRIMARY SHREDDERS CV-104/204 AT THE MID-  
CONNECTICUT WASTE PROCESSING FACILITY  
AGREEMENT**

**PARTS AND LABOR SPECIFICATIONS**

**PARTS AND LABOR SPECIFICATIONS  
FOR  
REFURBISHMENT OF PRIMARY SHREDDERS CV-104/204  
AT THE  
MID-CONNECTICUT WASTE PROCESSING FACILITY**

**CONTENTS**

1.	SHREDDER LOCATION/PLANT OPERATION .....	2
2.	SCOPE OF WORK .....	2
2.1	Engineering .....	2
2.2	Fabrication .....	3
2.3	Installation .....	3
3.	WORK TO BE PERFORMED .....	4
4.	WORK BY OTHERS .....	4
5.	DRAWINGS .....	5
6.	ENGINEERING REQUIREMENTS .....	5
6.1	General Performance Conditions .....	5
6.2	Installation – Method Of Replacement .....	5
7.	CHECKOUT, STARTUP AND INITIAL OPERATIONS .....	6
7.1	General .....	6
7.2	Operational Control And System Turnover .....	6
8.	COMPLETION SCHEDULE .....	6
9.	WARRANTY .....	7
10.	WORKING ON SITE .....	7
10.1	Cleaning Of The Work Area .....	7
10.2	Safety At The WPF .....	7

## 1. SHREDDER LOCATION/PLANT OPERATION

The Waste Processing Facility (“WPF”) portion of the Connecticut Resources Recovery Authority (“CRRA”) Mid-Connecticut Resource Recovery Facility (“RRF”) is located at 300 Maxim Road, Gate 70, Hartford, Connecticut. The Mid-Connecticut RRF is a waste-to-energy plant. The WPF is operated by the Metropolitan District Commission (“MDC”) under contract to CRRA. The MDC shall designate a representative to work closely with CRRA and the Contractor throughout the duration of the Agreement (the “MDC Representative”). “Engineer” means the duly authorized agent of CRRA.

At the WPF, municipal solid waste (“MSW”) is fed onto a series of conveyors and from there the waste is processed by a series of process equipment, which size the material into a burnable product, removing recyclables and other unwanted material from the waste stream. The WPF has two processing lines that are identical to each other and that are designated by CRRA as processing line 1 and processing line 2. Along each processing line there are primary shredders. The primary shredders are flail mills which break the bags of MSW and prepare the material for the additional separation and final shredding. The primary shredders have the equipment number of CV-104 and CV-204.

The Contractor shall supply the engineering drawings, material, equipment and the labor to replace all steel casings and wear pieces for both primary shredders. This is to include, but not be limited to, replacement of the top cover, lower chute, bearing base, anvil plate and target plate as well as repair or replacement, as needed, of the structural steel around the shredder. The scope of work also requires rotor removal and reinstallation after all work has been completed.

## 2. SCOPE OF WORK

### 2.1 Engineering

The Contractor shall generate engineering drawings that will be used to fabricate the shredder parts. The Contractor shall use the drawings included as **Exhibit B** as a reference. The Contractor must field measure the primary shredder housings and generate its own drawings. The primary shredder room will be made available to the Contractor for making the field measurements Monday through Saturday only after processing is completed and all day Sunday. The Contractor shall notify the MDC at least one day in advance of when it intends to make the field measurements to obtain MDC’s approval for the visit. The CRRA and MDC reserve the right to change, modify or add to any of the drawings as appropriate to comply with the nature of the operation of the primary shredders.

The drawings shall include, but not be limited to, the following parts:

- Primary shredder hood upper section;
- Primary shredder lower section;
- Hood cylinder mounting flanges;

- Primary shredder bearing mounting base structure for the rotor;
- Location of anvil plate and structure support; and
- Location of target plate and structure support.

## 2.2 Fabrication

The Contractor shall be responsible for designing, constructing and the fabrication of the primary shredders at the WPF in accordance with all applicable codes, standards, regulations and applicable laws, including:

- American Iron and Steel Institute (AISI);
- American National Standards institute (ANSI);
- American Society of Mechanical Engineers (ASME);
- American Welding Society (AWS);
- American Society for Testing And Material (ASTM);
- National Fire Protection Association (NFPA);
- Occupational Safety and Health Administration (OSHA);
- City of Hartford Codes and regulations; and
- All other applicable codes and regulations.

All new steel used in the fabrication shall meet the requirements of ASTM A-36 steel unless other wise noted. Structural bolts shall be ASTM A-325. Attachment bolts shall be grade 8 or higher.

The Contractor shall monitor the quality of incoming material, employee workmanship and the workmanship of subcontractors, and site conditions so as to produce work of the quality specified in this Exhibit A. Any work or products that are found by the CRRA or the MDC to be deficient shall be immediately removed or corrected.

The Contractor shall complete field fabrication of the housing parts of the primary shredders as specified in the drawings prepared pursuant to Section 2.1.

All steel erection done shall meet or exceed “Specification for Design, Fabrication and Erection of Structural Steel Buildings” of American Institute of Steel Construction, 1991 (or latest) edition.

## 2.3 Installation

This specification covers the removal of the existing primary shredders and the installation of new components. New component include the shredder upper cover, the lower housing, the hood liner plates, the side liner plates, the hydraulic hood cylinders, bearings bases, anvil and target plates. It is the Contractor responsibility as part of this contract to remove and reinstall the primary shredder rotors after completing the primary shredders installation.

It is the responsibility of the Contractor to install the rotor bearings and the drive belts and align the drive motor and rotor.

### 3. WORK TO BE PERFORMED

- (a) The Contractor will remove, modify and install material and components, and install new replacement parts for the primary shredders as per the drawings required by Section 2.1. The Contractor will insure that the primary shredders are in good running condition after all work is complete. All the steel will be provided by the Contractor. The following table specifies the material schedule.

Item	Description	Quantity
Complete shredder housing	Upper hood, Shredder body, Discharge Hopper and all attachments	1
Bearings base	Per Contractor's drawings	1 set
Hood liner plates	See drawing 104/204 Hood	1 set
Side liner plates	See drawing 104/204 Side	1 set
Anvil plate	See drawing 104/204 Anvil	1
Target plate w/ retaining bars	See drawing 104/204 Target	1
Bolts and Nuts	As needed	As needed
Structural support steel	As needed	As needed

- (b) The Contractor shall agree that all parts of the primary shredder system, which are not being replaced, have to be left as-is or reinstalled by the Contractor when the primary shredder replacement is completed.
- (c) The Contractor shall not proceed with the installation, until the inventory of all fabricated sections are completed and delivered to the site; any pre-assembly that is required shall be done prior to commencing the work.
- (d) Any material removed can be disposed of inside the WPF site metals container, but must be cut to fit properly in this container.
- (e) The Contractor shall comply with the time schedule and complete all required work on time. Any deviations by the Contractor will result in fines.

### 4. WORK BY OTHERS

- (a) The CRRA or MDC will perform work and supply material not included in this specification that may affect the installation.

- (b) The MDC or others will connect the safety and bearings protection devices.
- (c) The MDC will assist and guide the Contractor through the project to make sure that the project is executed in accordance with the schedule.

## **5. DRAWINGS**

The Contractor will be supplied with drawings showing the general structure of the primary shredders. The drawings supplied by CRRA may or may not have all dimensions that are required for the fabrication. Therefore, these drawing are for reference only. Exact dimensions must be field measured by the Contractor as specified in Section 2.1 of this document. The Contractor shall submit one electronic Auto CAD set of drawings and three sets of hard copy size A, stamped by a professional engineer licensed in Connecticut.

The reference drawings included in **Exhibit B** are provided with this specification and are to be considered as part of this specification.

## **6. ENGINEERING REQUIREMENTS**

### **6.1 General Performance Conditions**

These provisions shall apply to all fabricated and purchased assemblies supplied under this specification.

Any equipment supplied by the Contractor shall be the product of a manufacturer experienced in the design, fabrication and installation of equipment for the purpose required.

### **6.2 Installation – Method Of Replacement**

The Contractor shall decide the method of removal/replacement, review the proposed method with CRRA and MDC engineers and shall receive approval from the engineers for Contractor's desired method prior to the work commencement. The Contractor shall supply all tools, welding supplies and rigging equipment as required to complete the work. If the Contractor needs any conduits and/or sprinkler piping removed to do the work, he must specifically request this of the MDC five (5) days prior to commencement of the work. Any bracing, conduits, guarding or other obstructions that the Contractor requires removed in order to remove/install the floor plates will be performed by the Contractor, including reinstallation of those items. Any process equipment, piping, building structure or conduit damaged during this work must be repaired to a pre-existing condition. If during the removal/installation of the floor, an unforeseen problem occurs or the job cannot be finished within the allocated time, the MDC shall be notified immediately by the Contractor. The Project Engineer must approve any downtime occurring due to overage on installation time. If parts of the sidewall or the frame are

found to be deteriorated or excessively worn, the Contractor is expected to modify and replace any part that has excessive wear or corrosion to overcome these problems.

## 7. CHECKOUT, STARTUP AND INITIAL OPERATIONS

### 7.1 General

The Contractor shall render all services and do all work required to refurbish the primary shredders.

### 7.2 Operational Control And System Turnover

Prior to start up, The Contractor shall review the work with the Shift Supervisor and the MDC Project Engineer to insure that the primary shredder and other affected equipment are ready for start up and that all personnel, tools, fabrication material and other items that may affect operation have been cleared from the area.

Testing and checking of equipment will not limit or minimize in any way the Contractor's responsibility for the equipment or its operation or its long-term performance.

## 8. COMPLETION SCHEDULE

The Contractor shall comply with the following schedule:

Description	Total Time	Notes
Field measurement	1 week	Primary Shredder available for field measurements 12:00 a.m. to 7:00 a.m. Monday through Saturday and all day Sunday.
Drawings	3 weeks	Must be approved by CRRA and the MDC Engineer.
Fabrication	4 weeks	Must be delivered on site and stacked before the start of installation.
Installation	80 hours	Installation for each Primary Shredder must start on a Friday night at 2300 and must be completed by Tuesday morning at 0700.

The MDC will surrender ONE primary shredder at a time for this work. The MDC will surrender one of the primary shredders on a Friday at 11:00 p.m. and the Contractor must complete the work on the shredder by Tuesday at 7:00 a.m. The second primary shredder will be surrendered by MDC on a subsequent Friday at 11:00 p.m. and the Contractor must complete the work on the shredder within the same time frame as for the first primary shredder.



During the time allocated for the installation of the primary shredder assembly inside the shredder room, the MDC may choose to process MSW on the other processing line. Therefore the front door area of the running line will be off-limits for any use. The Contractor shall keep its tools, equipment and personnel out of the taped area.

## **9. WARRANTY**

The Contractor shall warrant the labor and any material supplied by the Contractor for a period of one year after CRRA and MDC acceptance of the work.

## **10. WORKING ON SITE**

Work areas are to be left clean at the end of each working day. Material that is to be stored on site will be stored in a location as specified by the MDC. The CRRA or MDC shall not take responsibility for any material or equipment left on site. The Contractor shall take all the necessary precautions to prevent damage to new and existing utilities, facilities and structures, and to prevent injury to personnel. The Contractor shall be responsible for all damage to utilities, structures and injuries to personnel resulting from its operations. The Contractor will be allowed to bring a portable office onto the site and place it in a suitable area approved by the MDC Project Engineer. The Contractor shall be responsible for providing all safety devices and or protection for all his employees or subcontractors while working at the facility.

### **10.1 Cleaning Of The Work Area**

Prior to start of work by the Contractor on a particular primary shredder, the MDC will clean that primary shredder by use of air wands. This cleaning will be completed prior to 12:00 p.m. All of the equipment and walkways associated with the subject shredder will be cleaned. The process line will be run clean before the shredder is turned over to the Contractor. Due to the nature of the facility, some residue will be left on the equipment and floor.

Any additional cleaning needed by the Contractor above and beyond normal daily cleaning (Contractor is to observe prior to starting of work), shall be the responsibility of the Contractor. The cleaning time will be included in the hours allowed for removal/installation.

### **10.2 Safety At The WPF**

In order to protect the safety and health of the Contractor's employees under this Agreement, the Contractor will comply with all pertinent provisions of the regulations of U.S. Department of Labor's Occupational Safety and Health Administration (CFR Chapter XVII parts 1910 and parts 1926 and the latest revisions and amendments).

The Contractor shall abide by the WPF lock out/tag out program and shall apply its lock-out locks to equipment that have been de-energized to perform the work under this Agreement. These locks shall be easily identified as the Contractor's lock-out locks.

Cutting and welding inside the plant will only be permitted when the Contractor has the approval of the MDC. A hot work permit will be issued and signed by both the Contractor and the MDC shift supervisor. In any case, the Contractor shall provide a person assigned solely to fire watch when welding or torching takes place in the WPF. The Contractor will be required to provide a tightly sealed firebreak between the work area and other conveyors. The Contractor shall also be responsible to protect any equipment that may be potentially damaged by cutting and welding sparks (i.e. motors, rubber belting etc.). The Contractor must be extremely careful when perform welding works near running conveyors due to a significant fire hazard.

The Contractor shall be responsible for the safety, efficiency and adequacy of its appliances and methods. Any and all damage that may result from the failure or improper construction, maintenance or operation shall be repaired or replaced at the Contractor's expense. Damage shall include personnel injuries and costs associated with limiting production.

The Contractor shall be responsible for the acts and omissions of its agents, employees and its subcontractors and their agents and employees. The Contractor shall hold the CRRA and MDC harmless and defend the CRRA and MDC against damages or claims for damages arising out of injuries to others or property of others that result from said acts or omissions. A brochure titled "Information for Contractors Working on Site" will be provided by the MDC and should be thoroughly reviewed by the Contractor. Also the Contractor will be responsible for meeting with the MDC and verifying all restricted areas by reviewing drawing #MGI13098-A3. While the Contractor is working on site, these restricted areas must not be entered during processing as operations can create potentially explosive environments. If a Contractor does enter these areas, processing will be immediately shut down. Any extensive down time caused by the Contractor will result in back charges.

If at any time, in the sole judgment of the CRRA or MDC, the work is not safe in regard to persons on or about the work, the CRRA or MDC shall have the right to order such safeguards to be erected. The CRRA or MDC shall not be responsible for the safety of any of the Contractor's employees or subcontractors at the WPF. The Contractor has the sole responsibility for the safety of its employees and following the operation and safety procedures of the WPF. If under such circumstances, the Contractor does not or can not immediately put the work and the safeguards into proper and approved conditions, the CRRA or MDC may put the work into such condition that it shall be, in the CRRA or MDC opinion, safe in all respects. The Contractor shall pay all costs and expenses incurred by the CRRA or MDC or owner in so doing. Such action of the CRRA or MDC or failure of the CRRA or MDC to take such action, shall in no way diminish the responsibility of the Contractor for any and all costs, expenses, losses, liability, claims, suits, proceedings, judgments, awards or damages resulting from the insufficiency of the safety precautions taken by it or by the Engineer acting under authority of this subsection.

Hard hats, steel toed shoes, pants, shirts and safety glasses must be worn while working on site at all times. All OSHA requirements will be abided by when working in the WPF (e.g., fall protection).

The CRRA and MDC hold the right to dismiss any of the Contractor's workers or subcontractors working at the WPF with proper justification. This is at the discretion of the CRRA or MDC.

Operating and Safety procedures for the WPF will be reviewed with the Contractor prior to work being performed at the WPF.

**EXHIBIT B**

To

**REFURBISHMENT OF  
PRIMARY SHREDDERS CV-104/204 AT THE MID-  
CONNECTICUT WASTE PROCESSING FACILITY  
AGREEMENT**

**DRAWINGS**

**EXHIBIT B**  
**DRAWINGS**

The following drawings are hereby incorporated by reference and made a part of this Agreement as if such plans had been attached in their entirety to this Agreement:

<b>DRAWING NO.</b>	<b>DRAWING DESCRIPTION</b>
D-WF-109-1	Primary Shredder Body
D-WF-165-1	Discharge Hopper Assembly
D-WF-166-1	Discharge Hopper
D-WF-101-5	General Arrangement
D-WF-102-3	Shredder Assembly
104-204 Anvil	Anvil Plate
6645-1	Shredder Liner Plate
6645-2	Shredder Liner Plate
104/204 Side	Side Liner Plates
101/204 Target	Target Plate











ITEM	PART No.	DESCRIPTION	QTY.
1	WF-108	SHREDDER COVER	1
2	WF-107	SHREDDER BODY	1
3	WF-170	ROTOR	1
4	WF-171	ANVIL PLATE	1
5	MI-2179	PILLOW Bk. BEARING FREE	1
6	MI-2179A	PILLOW Bk. BEARING FILED	1
7	SEE B/M	HAMMER	32
8	SEE B/M	HAMMER SPACER	32
9	SEE B/M	HAMMER SPACER	32
10	WF-174	HAMMER PIN	4
11	WF-101	SIDE LINER	1
12	WF-101A	SIDE LINER	1
13		1/8" HEX. SCR. NO. CAP. SCR. X 2 1/4" L.	14
14		3/4" HEX. BOLT X 2 1/2" L. S. X 1/4" DIA.	22
15		1" WOOD SCREW X 4 1/2" L. S. X 1/4" DIA.	8
16		1" WOOD SCREW X 4 1/2" L. S. X 1/4" DIA.	8
17		METRIC HD. BUSHING 3/8" X 1/2"	2
18		1/4" PIPE STREET ELBOW	1
19		1/4" PIPE NIPPLE X 6 L.	1
20		1/4" PIPE COUPLING	1
21	MP-11436	SIGHT GAUGE F.S. w/ INCH SCALES	2
22	MP-1283	SERIAL No. PLATE	1
23	MP-1281A	CAUTION TAG	2
24		1/4" MET. DR. SCR. X 3/16" L. W. TTPE-LI	12
25		1/8" HEX. NUT	14

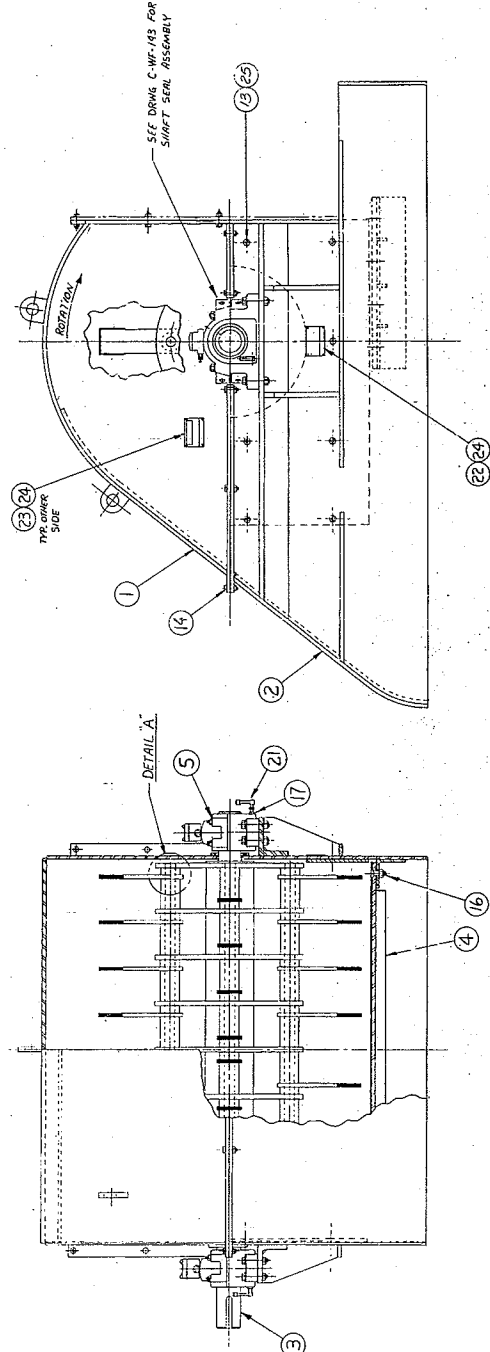
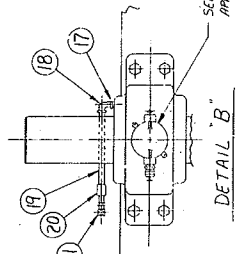
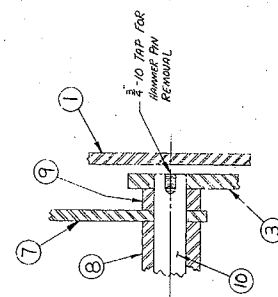
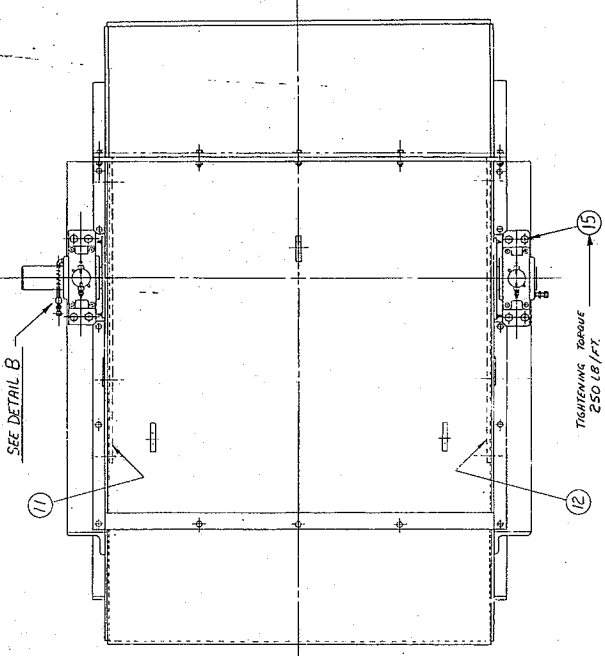

FOR HAMMER ASSEMBLY DRAWING SEE B/M

EST. WT. = 14,200 LBS.

CONTRACT NO. 45385  
**SHREDDER ASSEMBLY**  
 FOR **PRIMARY SHREDDER**  
 M.S.W. PROCESSING  
 M.S.W. PROCESSING  
 CHECKED BY: [Signature]  
 APPROVED BY: [Signature]  
 DATE: 12-19-15  
 THIS DRAWING IS THE PROPERTY OF  
 CONSULTING ENGINEERS, INC.  
 IT IS TO BE KEPT IN CONFIDENCE AND  
 NOT TO BE REPRODUCED OR COPIED  
 FOR ANY PURPOSE WITHOUT THE WRITTEN  
 PERMISSION OF CONSULTING ENGINEERS, INC.  
 BY AGREEMENT WITH SAID COMPANY.

DRAWING NO. **D-WF-102-3**  
 0-54-5554  
 0-72-44

ORIGINAL

J-1

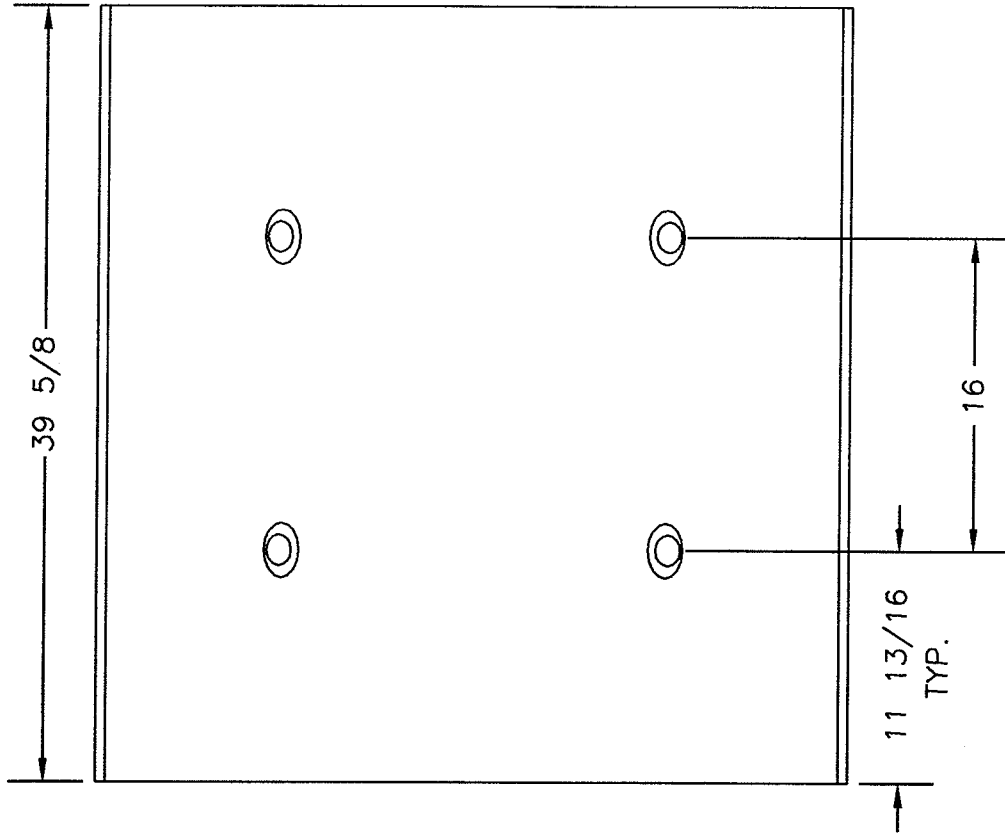

MATERIAL = NI BRAZE--A  
 REQUIRED: 6 pieces

5" ALONG PERIF. (37 1/2 IS RAD.) TYP.

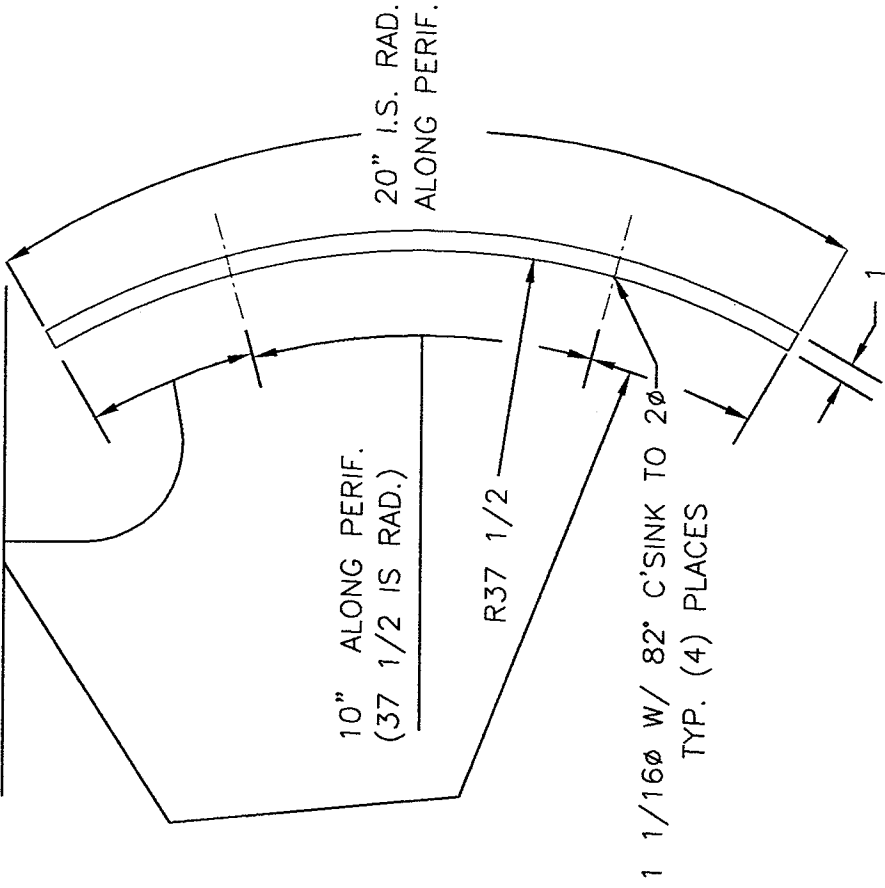

DRAWN BY	DRAWING TITLE		DATE	CUSTOMER	SIZE	DWG	REV.
	APPROVED BY	SHREDDER COVER LINER PLATES					
DATE	8/9/92	WORK ORDER	ABB-RRS	6645-1	1		
SCALE	1/10						
TOLERANCES							
FRACTIONS ± F-10L							
DECIMALS ± .01							
ANGLES ± 0'-15"							

1 1/16Ø W/82° C'SINK TO 2Ø  
TYP. (4) PLACES

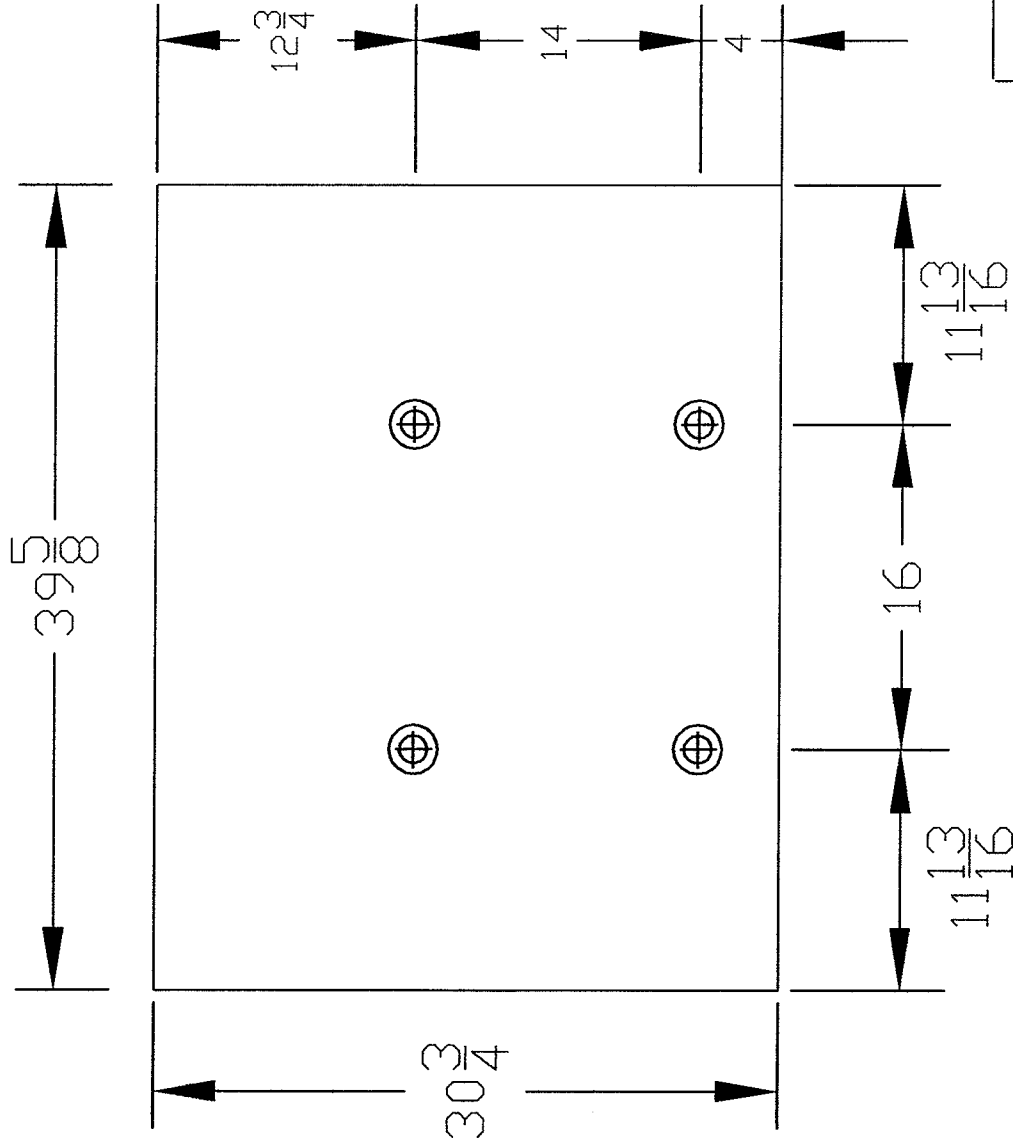

MATERIAL = NI BRAZE-A  
REQUIRED: 2 pieces

DRAWN BY	DRAWING TITLE		SIZE	DWG	REV.
	APPROVED BY	SHREDDER COVER LINER PLATES			
DATE	CUSTOMER	WORK ORDER	A	6645-2	1
8/9/92	ABB-RRS				
SCALE	TOLERANCES				
1/10	FRACTIONS ± F-TOL				
	DECIMALS ± 0.01				
	ANGLES ± 0-15'				

# PRIMARY SHREDDER SIDE LINER MODIFIED

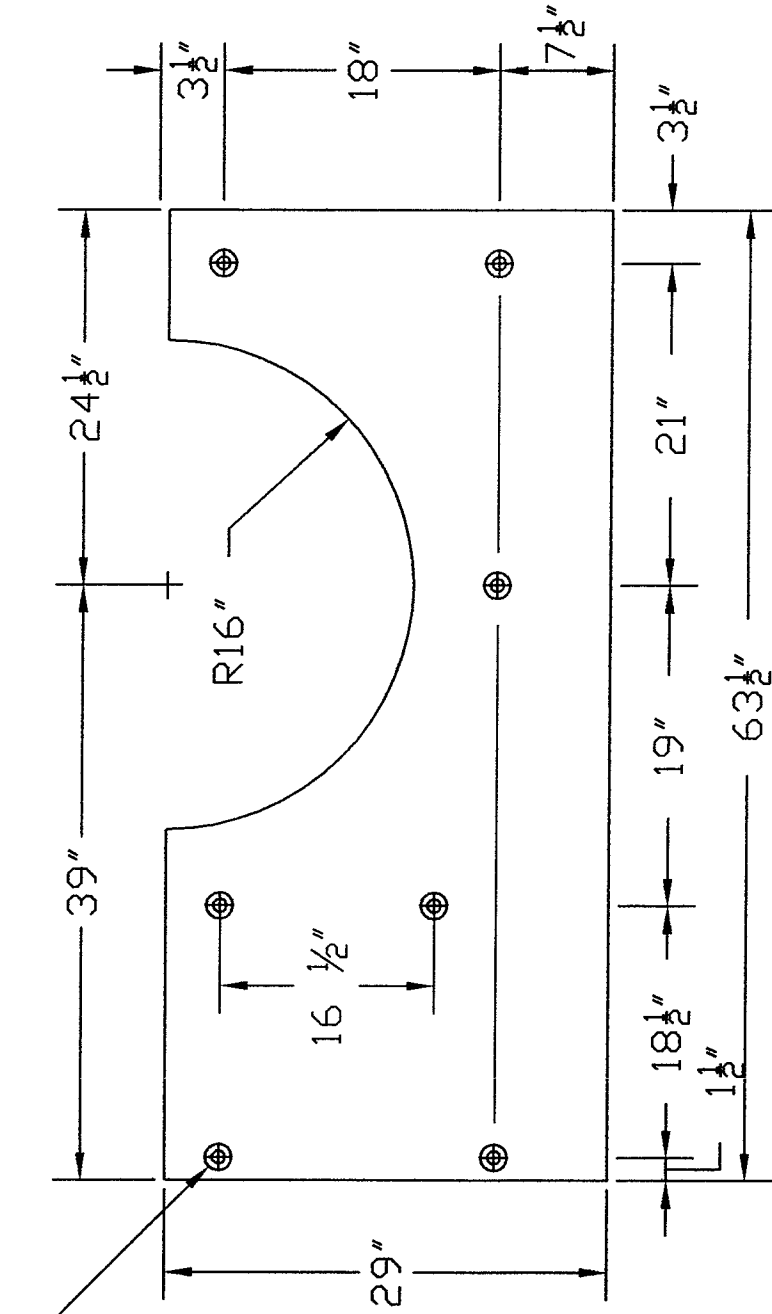

7/8"  $\phi$  7 HOLES

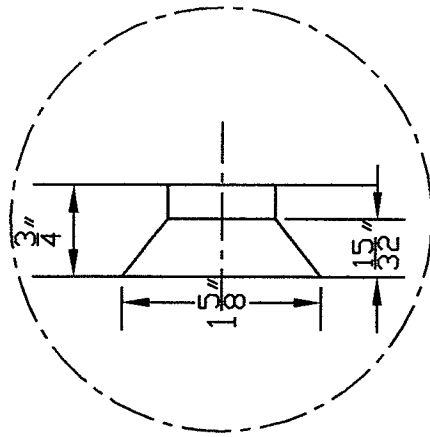

TOLERANCES:  $\pm \frac{1}{32}$ "  
 ANGULAR  $\pm \frac{1}{16}$ "  
 PUNCHED HOLES  $\pm \frac{1}{32}$ "  
 DRILLED HOLES  $+0.010$   
 -0.000

**MATL: 3/4" THICK AR400  
 REQUIRED 1 L.H & 1 R.H**

DRAWING BY ABDUL RABAH		DRAWING TITLE 104 SIDE LINER	
APPROVED BY		DRAWING NO. 104/204	
DATE 8/12/04	SCALE	REV.	SIZE
TOLERANCE			

**104/204 Target Plate**

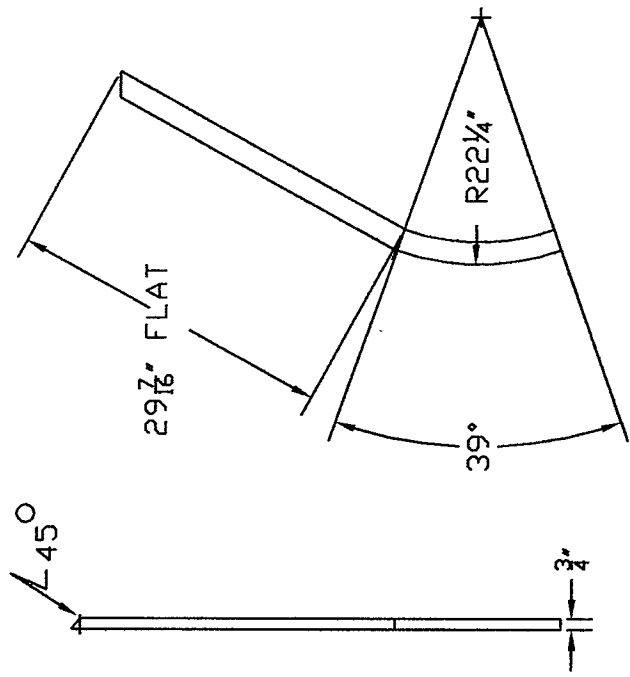
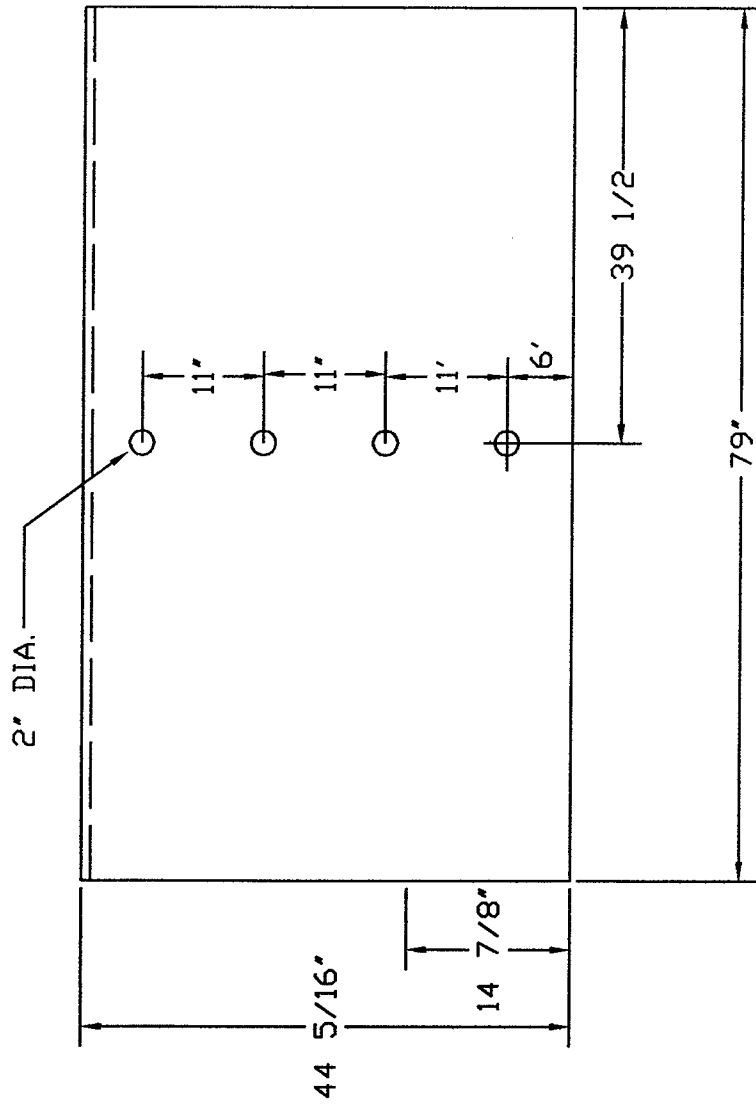

**Material AR400 / Mancro 400**

**Tolerance: Plate  $\pm 1/32$**

**: drilled holes  $+0.0156$   
-0.000**

**REQUIRED 1 PLATE**

DESIGNED BY ABDUL RABAH	DRAWING TITLE 104 target Plate
APPROVED BY	DRAWING NO. 104/204
DATE 11/18/02	REV.
SCALE	SIZE
TOLERANCE	

**EXHIBIT C**

To

**REFURBISHMENT OF  
PRIMARY SHREDDERS CV-104/204 AT THE MID-  
CONNECTICUT WASTE PROCESSING FACILITY  
AGREEMENT**

**PROJECT SCHEDULE**

**EXHIBIT C**  
**PROJECT SCHEDULE**

Description	Total Time	Notes
Field measurement	1 week	Primary Shredder available for field measurements 12:00 a.m. to 7:00 a.m. Monday through Saturday and all day Sunday.
Drawings	3 weeks	Must be approved by CRRA and the MDC Engineer.
Fabrication	4 weeks	Must be delivered on site and stacked before the start of installation.
Installation	80 hours	Installation for each Primary Shredder must start on a Friday night at 2300 and must be completed by Tuesday morning at 0700.



**EXHIBIT D**

To

**REFURBISHMENT OF  
PRIMARY SHREDDERS CV-104/204 AT THE MID-  
CONNECTICUT WASTE PROCESSING FACILITY  
AGREEMENT**

**PERFORMANCE BOND FORM**

**AND**

**LETTER OF CREDIT FORM**

# PERFORMANCE BOND

Any singular reference to Contractor, Surety, Owner or other party shall be considered plural where applicable. The below addresses are to be used for giving required notice.

**CONTRACTOR** (Name and Address):

**SURETY** (Name and Principal Place of Business):

--	--

**OWNER** (Name and Address):

Connecticut Resources Recovery Authority 100 Constitution Plaza, 6 <sup>th</sup> Floor Hartford, CT 06103-1722
--

**AGREEMENT**

<b>DATE:</b>	
<b>AMOUNT:</b>	
<b>PROJECT DESCRIPTION</b> <small>(Including Name and Location):</small>	Refurbishment Of Primary Shredders CV-104/204 At The Mid-Connecticut Waste Processing Facility Mid-Connecticut Waste Processing Facility 300 Maxim Road, Gate 70 Hartford, Connecticut 06114

**BOND**

<b>BOND NUMBER:</b>	
<b>DATE:</b> (Not earlier than Agreement Date)	
<b>AMOUNT:</b>	DOLLARS (\$ _____ )

IN WITNESS WHEREOF, Surety and Contractor, intending to be legally bound hereby, subject to the terms printed on Pages 2 and 3 hereof, do each cause this Performance Bond to be duly executed on its behalf by its authorized officer, agent, or representative.

**CONTRACTOR AS PRINCIPAL**

**SURETY**

--

(SEAL)

--

(SEAL)

Contractor's Name and Corporate Seal

Surety's Name and Corporate Seal

<b>SIGNATURE:</b>		<b>SIGNATURE:</b>	
<b>NAME AND TITLE:</b>		<b>NAME AND TITLE:</b>	

## TERMS AND CONDITIONS TO PERFORMANCE BOND

1. The Contractor and the Surety jointly and severally bind themselves, their heirs, executors, administrators, successors and assigns to the Owner for the performance of the foregoing Agreement, the terms of which are incorporated herein by reference. Any singular reference to the Contractor, the Surety, the Owner or any other party herein shall be considered plural where applicable.
2. If the Contractor performs the Agreement, the Surety and the Contractor shall have no obligation under this Bond, except to participate in conferences as provided in Subparagraph 3.1.
3. If there is no Owner Default (as hereinafter defined), the Surety's obligation under this Bond shall arise after:
  - 3.1 The Owner has notified the Contractor and the Surety at its address described in Paragraph 10 below, that the Owner is considering declaring a Contractor Default (as hereinafter defined) and has requested and attempted to arrange a conference with the Contractor and the Surety to be held not later than fifteen (15) days after the receipt of such notice to discuss methods of performing the Agreement. If the Owner, the Contractor and the Surety agree, the Contractor shall be allowed a reasonable time to perform the Agreement, but such an agreement shall not waive the Owner's right, if any, to subsequently declare a Contractor Default; and
  - 3.2 The Owner has declared a Contractor Default (as hereinafter defined) and formally terminated the Contractor's right to complete the Agreement. Such Contractor Default shall not be declared earlier than twenty (20) days after the Contractor and the Surety have received notice as provided in Subparagraph 3.1.
  - 3.3 The Owner has agreed to pay the Balance of the Agreement Price to the Surety in accordance with the terms of the Agreement or to a contractor selected to perform the Agreement in accordance with the terms of the agreement with the Owner.
4. When the Owner has satisfied the conditions of Paragraph 3, the Surety shall promptly and at the Surety's expense take one of the following actions:
  - 4.1 Arrange for the Contractor, with the consent of the Owner, to perform and complete the Agreement; or
  - 4.2 Undertake to perform and complete the Agreement itself, through its agents or through independent contractors; or
  - 4.3 Obtain bids or negotiated proposals from qualified contractors acceptable to the Owner for a contract for performance and completion of the Agreement, arrange for a contract to be prepared for execution by the Owner and the contractor selected with the Owner's concurrence, to be secured with a performance bond executed by a qualified surety equivalent to the bond issued on the Agreement, and pay to the Owner the amount of damages described in Paragraph 6; or
  - 4.4 Waive its right to perform and complete, arrange for completion or obtain a new contractor and with reasonable promptness under the circumstances:
    - 4.4.1 After investigation, determine the amount for which it may be liable to the Owner and, as soon as practicable after the amount is determined, tender payment therefor to the Owner; or
    - 4.4.2 Deny liability in whole or in part and notify the Owner citing reasons therefor.
5. If the Surety does not proceed as provided in Paragraph 4 with reasonable promptness, the Surety shall be deemed to be in default on this Bond fifteen (15) days after receipt of an additional written notice from the Owner to the Surety demanding that the Surety perform its obligations under this Bond, and the Owner shall be entitled to enforce any remedy available to the Owner. If the Surety proceeds as provided in Subparagraph 4.4 and the Owner refuses the payment tendered or the Surety has denied liability, in whole or in part, without further notice the Owner shall be entitled to enforce any remedy available to the Owner.
6. After the Owner has terminated the Contractor's right to complete the Agreement, and if the Surety elects to act under Subparagraph 4.1, 4.2 or 4.3 above, then the responsibilities of the Surety to the Owner shall not be greater than those of the Contractor under the Agreement, and the responsibilities of the Owner to the Surety shall not be greater than those of the Owner under the Agreement. To the limit of the amount of this Bond, the Surety is obligated without duplication for:
  - 6.1 The responsibilities of the Contractor for correction of defective work and completion of the Agreement;
  - 6.2 Additional legal and delay costs resulting from the Contractor's Default and resulting from the actions or failure to act of the Surety under Paragraph 4; and
  - 6.3 Liquidated damages, or if no liquidated damages are specified in the Agreement, actual damages caused by delayed performance or non-performance of the Contractor.
7. The Surety shall not be liable to the Owner or others for obligations of the Contractor that are unrelated to the Agreement. No right of action shall accrue on this Bond to any person or entity other than the Owner or its successors and assigns.
8. The Surety hereby waives notice of any change, including changes of time, to the Agreement or to related subcontracts, purchase orders and other obligations.
9. Any proceeding, legal or equitable, under this Bond may be instituted in any court of competent jurisdiction in the location in which the work or part of the work is located and shall be instituted within two (2) years after Contractor Default or within two (2) years after the Contractor ceased working or within two (2) years after the Surety refuses or fails to perform its obligations under this Bond, whichever occurs first. If the provisions

of this Paragraph are void or prohibited by law, the minimum period of limitation available to sureties as a defense in the jurisdiction of the suit shall be applicable.

10. Notice to the Surety, the Owner or the Contractor shall be mailed or delivered to the address shown on the signature page of this Bond.
11. When this Bond has been furnished to comply with a statutory or other legal requirement in the location where the Agreement was to be performed, any provision in this Bond conflicting with said statutory or legal requirement shall be deemed deleted here from and provisions confirming to such statutory or other legal requirement shall be deemed incorporated herein. The intent is that this Bond shall be construed as a statutory bond and not as a common law bond.

12. Definitions.

12.1 Balance of the Agreement Price: The total amount payable by the Owner to the Contractor under the Agreement after all proper adjustments have been made, including allowance to the Contractor of any amounts received or to be received by the Owner in settlement of insurance or other claims for damages to which the Contractor is entitled, reduced by all valid and proper payments made to or on behalf of the Contractor under the Agreement.

12.2 Agreement: The agreement between the Owner and the Contractor identified on the signature page, including all Agreement Documents and changes thereto.

12.3 Contractor Default: Failure of the Contractor, which has neither been remedied nor waived, to perform or otherwise to comply with any of the terms of the Agreement.

12.4 Owner Default: Failure of the Owner, which has neither been remedied nor waived, to perform or otherwise to comply with the terms of the Agreement or to perform and complete or comply with the other terms hereof.

# LETTER OF CREDIT

To Be Issued By a Connecticut Bank Or By a National Banking Association

Irrevocable Standby Letter Of Credit No.	[LETTER OF CREDIT #]		
Issuance Date:	[DATE]	Expiration Date:	[DATE]
Beneficiary:	Connecticut Resources Recovery Authority 100 Constitution Plaza, 6th Floor Hartford, CT 06103		

Gentlemen:

We hereby establish our Irrevocable Standby Letter Of Credit No. **[Letter Of Credit #]** in favor of the "Beneficiary," Connecticut Resources Recovery Authority ("CRRA"), at the request and for the account of **[Name of Contractor]**, for the sum or sums up to the aggregate amount of **[amount of Letter Of Credit]** available for payment against your draft(s) at sight on us.

Drafts must be drawn and presented to us at this office not later than our close of business on **[Date]** or any duly extended expiration date, and each draft must bear the following clause: "Drawn Under Letter Of Credit No. **[Letter Of Credit #]**."

Drafts must be accompanied by a certified statement from the Beneficiary that **[name of Contractor]** has failed to satisfy or perform one or more of its obligations or breached one or more of its covenants or representations under a certain Refurbishment Of Primary Shredders CV-104/204 At The Mid-Connecticut Waste Processing Facility Agreement between **[name of Contractor]** and CRRA, dated as of **[Date]**.

Partial drawings hereunder are permitted.

We hereby agree with you that drafts drawn under and in compliance with the above terms of this Letter Of Credit shall be duly and promptly honored on due presentation and delivery to us on or before the above-referenced expiration date or any duly extended expiration date.

The term "Beneficiary" includes any successor by operation of law of the named Beneficiary including, without limitation, any liquidator, rehabilitator, receiver or conservator.

Except as expressly stated herein, this undertaking is not subject to any agreement, condition or qualification. The obligation of **[name of the issuing Connecticut Bank or National Banking Association]** under this Letter of Credit is the individual obligation of **[name of the issuing Connecticut Bank or National Banking Association]** and is in no way contingent upon reimbursement with respect thereto.

It is a condition of this Letter Of Credit that it is deemed to be automatically extended without amendment for one (1) year from the expiration date stated above, or any future expiration date, unless not later than ninety (90) days prior to the expiration date stated above or the then current expiration date we notify you by registered mail that we elect not to renew this Letter Of Credit for any such additional period.

We hereby agree that all drafts drawn under and in compliance with the terms of this Letter Of Credit shall be duly honored by us at your first demand, notwithstanding any contestation or dispute between you and **[name of Contractor]**, if presented to us in accordance with the provisions hereof.

This Letter of Credit is subject to and governed by the laws of the State of Connecticut, the decisions of the courts of that state, and the Uniform Customs and Practice for Documentary Credits (1993 Revision) International Chamber of Commerce Publication No. 500 and in the event of any conflict, the laws of the State of Connecticut and the decisions of the courts of that state will control. If this Letter Of Credit expires during an interruption of business of this bank as described in Article 17 of said Publication 500, **[name of issuing Connecticut Bank or National Banking Association]** hereby specifically agrees to effect payment if this Letter of Credit is drawn against within thirty (30) days after the resumption of business from such interruption.

Very truly yours,

---

Authorized Signature for  
**[name of issuing Connecticut Bank or National Banking Association]**

**EXHIBIT E**

To

**REFURBISHMENT OF  
PRIMARY SHREDDERS CV-104/204 AT THE MID-  
CONNECTICUT WASTE PROCESSING FACILITY  
AGREEMENT**

**PAYMENT BOND FORM**

# PAYMENT BOND

Any singular reference to Contractor, Surety, Owner or other party shall be considered plural where applicable. The below addresses are to be used for giving required notice.

**CONTRACTOR** (Name and Address):

**SURETY** (Name and Principal Place of Business):

--	--

**OWNER** (Name and Address):

Connecticut Resources Recovery Authority 100 Constitution Plaza, 6 <sup>th</sup> Floor Hartford, CT 06103-1722
--

**AGREEMENT**

<b>DATE:</b>	
<b>AMOUNT:</b>	
<b>PROJECT DESCRIPTION</b> <small>(Including Name and Location):</small>	Refurbishment of Primary Shredders CV-104/204 At The Mid-Connecticut Waste Processing Facility Mid-Connecticut Waste Processing Facility 300 Maxim Road, Gate 70 Hartford, Connecticut 06114

**BOND**

<b>BOND NUMBER:</b>	
<b>DATE:</b> <small>(Not earlier than Agreement Date)</small>	
<b>AMOUNT:</b>	DOLLARS (\$ _____ )

IN WITNESS WHEREOF, Surety and Contractor, intending to be legally bound hereby, subject to the terms printed on Pages 2 and 3 hereof, do each cause this Payment Bond to be duly executed on its behalf by its authorized officer, agent, or representative.

**CONTRACTOR AS PRINCIPAL**

**SURETY**

--

(SEAL)

--

(SEAL)

Contractor's Name and Corporate Seal

Surety's Name and Corporate Seal

<b>SIGNATURE:</b>		<b>SIGNATURE:</b>	
<b>NAME AND TITLE:</b>		<b>NAME AND TITLE:</b>	



## TERMS AND CONDITIONS TO PAYMENT BOND

1. The Contractor and the Surety, jointly and severally, bind themselves, their heirs, executors, administrators, successors and assigns to the Owner to pay for labor, materials and equipment furnished for use in the performance of the Agreement, which is incorporated herein by reference.

thereof, to the Owner, stating that a claim is being made under this Bond and enclosing a copy of the previous written notice furnished to the Contractor.
2. With respect to the Owner, this obligation shall be null and void if the Contractor:
  - 2.1 Promptly makes payment, directly or indirectly, for all sums due Claimants, and
  - 2.2 Defends, indemnifies and holds harmless the Owner from claims, demands, liens or suits by any person or entity whose claim, demand, lien or suit is for the payment for labor, materials or equipment furnished for use in the performance of the Agreement, provided the Owner has promptly notified the Contractor and the Surety (at the address described in Paragraph 12) of any claims, demands, liens or suits and tendered defense of such claims, demands, liens or suits to the Contractor and the Surety, and provided there is no Owner Default.
3. With respect to Claimants, this obligation shall be null and void if the Contractor promptly makes payment, directly or indirectly, for all sums due.
4. The Surety shall have no obligation to Claimants under this Bond until:
  - 4.1 Claimants who are employed by or have a direct contract with the Contractor have given notice to the Surety (at the address described in Paragraph 12) and sent a copy, or notice thereof, to the Owner, stating that a claim is being made under this Bond and, with substantial accuracy, the amount of the claim.
  - 4.2 Claimants who do not have a direct contract with the Contractor:
    - 4.2.1 Have furnished written notice to the Contractor and sent a copy, or notice thereof to the Owner, within 90 days after having last performed labor or last furnished materials or equipment included in the claim stating, with substantial accuracy, the amount of the claim and the name of the party to whom the materials were furnished or supplied or for whom the labor was done or performed; and
    - 4.2.2 Have either received a rejection in whole or in part from the Contractor, or not received within 30 days of furnishing the above notice any communication from the Contractor by which the Contractor has indicated the claim will be paid directly or indirectly; and
    - 4.2.3 Not having been paid within the above 30 days, have sent a written notice to the Surety (at the address described in Paragraph 12) and sent a copy, or notice
5. If a notice required by Paragraph 4 is given by the Owner to the Contractor or to the Surety, that is sufficient compliance.
6. When the Claimant has satisfied the conditions of Paragraph 4, the Surety shall promptly and at the Surety's expense take the following actions:
  - 6.1 Send an answer to the Claimant, with a copy to the Owner, within 45 days after receipt of the claim, stating the amounts that are undisputed and the basis for challenging any amounts that are disputed.
  - 6.2 Pay or arrange for payment of any undisputed amounts.
7. The Surety's total obligation shall not exceed the amount of this Bond, and the amount of this Bond shall be credited for any payments made in good faith by the Surety.
8. Amounts owed by the Owner to the Contractor under the Agreement shall be used for the performance of the Agreement and to satisfy claims, if any, under any Performance Bond. By the Contractor furnishing and the Owner accepting this Bond, they agree that all funds earned by the Contractor in the performance of the Agreement are dedicated to satisfy obligations of the Contractor and the Surety under this Bond, subject to the Owner's priority to use the funds for the completion of the work.
9. The Surety shall not be liable to the Owner, Claimants or others for obligations of the Contractor that are unrelated to the Agreement. The Owner shall not be liable for payment of any costs or expenses of any Claimant under this Bond, and shall have under this Bond no obligations to make payments to, give notices on behalf of, or otherwise have obligations to Claimants under this Bond.
10. The Surety hereby waives notice of any change, including changes of time, to the Agreement or to related subcontracts, purchase orders and other obligations.
11. No suit or action shall be commenced by a Claimant under this Bond other than in a court of competent jurisdiction in the location in which the work or part of the work is located or after the expiration of one year from the date (1) on which the Claimant gave the notice required by Subparagraph 4.1 or Clause 4.2.3, or (2) on which the last labor or service was performed by anyone or the last materials or equipment were furnished by anyone under the Agreement, whichever of (1) or (2) first occurs. If the provisions of this Paragraph are void or prohibited by law, the minimum period of limitation available to sureties as a defense in the jurisdiction of the suit shall be applicable.

12. Notice to the Surety, the Owner or the Contractor shall be mailed or delivered to the address shown on the signature page. Actual receipt of notice by Surety, the Owner or the Contractor, however accomplished, shall be sufficient compliance as of the date received at the address shown on the signature page.
13. When this Bond has been furnished to comply with a statutory or other legal requirement in the location where the construction was to be performed, any provision in this Bond conflicting with said statutory or legal requirement shall be deemed deleted herefrom and provisions conforming to such statutory or other legal requirement shall be deemed incorporated herein. The intent is that this Bond shall be construed as a statutory bond and not as a common law bond.
14. Upon request by any person or entity appearing to be a potential beneficiary of this Bond, the Contractor shall promptly furnish a copy of this Bond or shall permit a copy to be made.
15. Definitions
  - 15.1 Claimant: An individual or entity having a direct contract with the Contractor or with a subcontractor of the Contractor to furnish labor, materials or

equipment for use in the performance of the Agreement. The intent of this Bond shall be to include without limitation in the terms "labor, materials or equipment" that part of water, gas, power, light, heat, oil, gasoline, telephone service or rental equipment used in the Agreement, architectural and engineering services required for performance of the work of the Contractor and the Contractor's subcontractors, and all other items for which a mechanic's lien may be asserted in the jurisdiction where the labor, materials or equipment were furnished,

- 15.2 Agreement: The agreement between the Owner and the Contractor identified on the signature page, including all Agreement Documents and changes thereto.
- 15.3 Owner Default: Failure of the Owner, which has neither been remedied nor waived, to pay the Contractor as required by the Agreement or to perform and complete or comply with the other terms thereof.

**EXHIBIT F**

**To**

**REFURBISHMENT OF  
PRIMARY SHREDDERS CV-104/204 AT THE MID-  
CONNECTICUT WASTE PROCESSING FACILITY  
AGREEMENT**

**PREVAILING WAGE BID PACKAGE**

# Prevailing Wage Bid Package

Last Updated: July 03, 2007

**You are here:** [DOL Web Site](#) › [Wage and Workplace Issues](#) › [Prevailing Wage Bid Package](#)

- › [Section 31-53b: Construction safety and Health Course. Proof of completion required for employees on public building projects. \(PDF, 10KB\)](#)
  - › [Informational Bulletin - The 10-Hour OSHA Construction Safety and Health Course \(PDF, 20KB\)](#)
- › [Notice For All Mason Contractors \(PDF, 5KB\)](#)
- › [CT General Statute 31-55a](#)
- › [Contracting Agency Certification Form \(PDF, 89KB\)](#)
- › [Contractor's Wage Certification Form \(PDF, 11KB\)](#)
- › [Payroll Certification - Public Works Projects](#)
- › [Occupational Classification Bulletin](#)
- › [Footnotes \(PDF, 101KB\)](#)

Published by the Connecticut Department of Labor, Automation Support Unit

**Sec. 31-53b. Construction safety and health course. Proof of completion required for employees on public building projects. Enforcement. Regulations.** (a) Each contract entered into on or after July 1, 2007, for the construction, remodeling, refinishing, refurbishing, rehabilitation, alteration or repair of any public building project by the state or any of its agents, or by an political subdivision of the state or any of its agents, where the total cost of all work to be performed by all contractors and subcontractors in connection with the contract is at least one hundred thousand dollars, shall contain a provision requiring that, not later than thirty days after the date such contract is awarded, each contractor furnish proof to the Labor Commissioner that all employees performing manual labor on or in such public building, pursuant to such contract, have completed a course of at least ten hours in duration in construction safety and health approved by the federal Occupational Safety and Health Administration or, in the case of telecommunications employees, have completed at least ten hours of training in accordance with 29 CFR 1910.268.

(b) Any employee required to complete a construction safety and health course required under subsection (a) of this section who has not completed the course shall be subject to removal from the worksite if the employee does not provide documentation of having completed such course by the fifteenth day after the date the employee is found to be in noncompliance. The Labor Commissioner or said commissioner's designee shall enforce this section.

(c) Not later than January 1, 2007, the Labor Commissioner shall adopt regulations, in accordance with the provisions of chapter 54, to implement the provisions of subsections (a) and (b) of this section. Such regulations shall require that the ten-hour construction safety and health courses required under subsection (a) of this section be conducted in accordance with federal Occupational Safety and Health Administration Training Institute standards, or in accordance with 29 CFR 1910.268, as appropriate. The Labor Commissioner shall accept as sufficient proof of compliance with the provisions of subsection (a) or (b) of this section a student course completion card issued by the federal Occupational Safety and Health Administration Training Institute, or such other proof of compliance said commissioner deems appropriate, dated no earlier than five years before the commencement date of such public works project.

(d) For the purposes of this section, "public building" means a structure, paid for in whole or in part with state funds, within a roof and within exterior walls or fire walls, designed for the housing, shelter, enclosure and support or employment of people, animals or property of any kind, including, but not limited to, sewage treatment plants and water treatment plants, "Public building" does not include site work, roads or bridges, rail lines, parking lots or underground water, sewer or drainage systems including pump houses or other utility systems.

## **Informational Bulletin**

### **THE 10-HOUR OSHA CONSTRUCTION SAFETY AND HEALTH COURSE**

(applicable to public building contracts entered into *on or after July 1, 2007*, where the total cost of all work to be performed is at least \$100,000)

- (1) This requirement was created by Public Act No. 06-175, which is codified in Section 31-53b of the Connecticut General Statutes (pertaining to the prevailing wage statutes);
- (2) The course is required for public building construction contracts (projects funded in whole or in part by the state or any political subdivision of the state) entered into on or after July 1, 2007;
- (3) It is required of private employees (not state or municipal employees) and apprentices who perform manual labor for a general contractor or subcontractor on a public building project where the total cost of all work to be performed is at least \$100,000;
- (4) The ten-hour construction course pertains to the ten-hour Outreach Course conducted in accordance with federal OSHA Training Institute standards, and, for telecommunications workers, a ten-hour training course conducted in accordance with federal OSHA standard, 29 CFR 1910.268;
- (5) The internet website for the federal OSHA Training Institute is [http://www.osha.gov/fso/ote/training/edcenters/fact\\_sheet.html](http://www.osha.gov/fso/ote/training/edcenters/fact_sheet.html);
- (6) The statutory language leaves it to the contractor and its employees to determine who pays for the cost of the ten-hour Outreach Course;
- (7) Within 30 days of receiving a contract award, a general contractor must furnish proof to the Labor Commissioner that all employees and apprentices performing manual labor on the project will have completed such a course;
- (8) Proof of completion may be demonstrated through either: (a) the presentation of a *bona fide* student course completion card issued by the federal OSHA Training Institute; *or* (2) the presentation of documentation provided to an employee by a trainer certified by the Institute pending the actual issuance of the completion card;
- (9) Any card with an issuance date more than 5 years prior to the commencement date of the construction project shall not constitute proof of compliance;

- (10) Each employer shall affix a copy of the construction safety course completion card to the certified payroll submitted to the contracting agency in accordance with Conn. Gen. Stat. § 31-53(f) on which such employee's name first appears;
- (11) Any employee found to be in non-compliance shall be subject to removal from the worksite if such employee does not provide satisfactory proof of course completion to the Labor Commissioner by the fifteenth day after the date the employee is determined to be in noncompliance;
- (12) Any such employee who is determined to be in noncompliance may continue to work on a public building construction project for a maximum of fourteen consecutive calendar days while bringing his or her status into compliance;
- (13) The Labor Commissioner may make complaint to the prosecuting authorities regarding any employer or agent of the employer, or officer or agent of the corporation who files a false certified payroll with respect to the status of an employee who is performing manual labor on a public building construction project;
- (14) The statute provides the minimum standards required for the completion of a safety course by manual laborers on public construction contracts; any contractor can exceed these minimum requirements; and
- (15) Regulations clarifying the statute are currently in the regulatory process, and shall be posted on the CTDOL website as soon as they are adopted in final form.
- (16) Any questions regarding this statute may be directed to the Wage and Workplace Standards Division of the Connecticut Labor Department via the internet website of <http://www.ctdol.state.ct.us/wgwkstnd/wgemenu.htm>; or by telephone at (860)263-6790.

**THE ABOVE INFORMATION IS PROVIDED EXCLUSIVELY AS AN EDUCATIONAL RESOURCE, AND IS NOT INTENDED AS A SUBSTITUTE FOR LEGAL INTERPRETATIONS WHICH MAY ULTIMATELY ARISE CONCERNING THE CONSTRUCTION OF THE STATUTE OR THE REGULATIONS.**

November 29, 2006

## Notice

### **To All Mason Contractors and Interested Parties Regarding Construction Pursuant to Section 31-53 of the Connecticut General Statutes (Prevailing Wage)**

The Connecticut Labor Department Wage and Workplace Standards Division is empowered to enforce the prevailing wage rates on projects covered by the above referenced statute.

Over the past few years the Division has withheld enforcement of the rate in effect for workers who operate a forklift on a prevailing wage rate project due to a potential jurisdictional dispute.

The rate listed in the schedules and in our Occupational Bulletin (see enclosed) has been as follows:

#### **Forklift Operator:**

- **Laborers (Group 4) Mason Tenders** - operates forklift solely to assist a mason to a maximum height of nine feet only.

- **Power Equipment Operator (Group 9)** - operates forklift to assist any trade and to assist a mason to a height over nine feet.

The U.S. Labor Department conducted a survey of rates in Connecticut but it has not been published and the rate in effect remains as outlined in the above Occupational Bulletin.

*Since this is a classification matter and not one of jurisdiction, effective January 1, 2007 the Connecticut Labor Department will enforce the rate on each schedule in accordance with our statutory authority.*

Your cooperation in filing appropriate and accurate certified payrolls is appreciated.



# Statute 31-55a

Last Updated: October 23, 2006

You are here: [DOL Web Site](#) » [Wage and Workplace Issues](#) » [Statute 31-55a](#)

## - Special Notice -

**To All State and Political Subdivisions, Their Agents, and Contractors**

**Connecticut General Statute 31-55a - Annual adjustments to wage rates by contractors doing state work.**

*Each contractor that is awarded a contract on or after October 1, 2002, for (1) the construction of a state highway or bridge that falls under the provisions of section 31-54 of the general statutes, or (2) the construction, remodeling, refinishing, refurbishing, rehabilitation, alteration or repair of any public works project that falls under the provisions of section 31-53 of the general statutes shall contact the Labor Commissioner on or before July first of each year, for the duration of such contract, to ascertain the prevailing rate of wages on an hourly basis and the amount of payment or contributions paid or payable on behalf of each mechanic, laborer or worker employed upon the work contracted to be done, and shall make any necessary adjustments to such prevailing rate of wages and such payment or contributions paid or payable on behalf of each such employee, effective each July first.*

- The prevailing wage rates applicable to any contract or subcontract awarded on or after October 1, 2002 are subject to annual adjustments each July 1st for the duration of any project which was originally advertised for bids on or after October 1, 2002.
- Each contractor affected by the above requirement shall pay the annual adjusted prevailing wage rate that is in effect each July 1st, as posted by the Department of Labor.
- It is the **contractor's** responsibility to obtain the annual adjusted prevailing wage rate increases directly from the Department of Labor's Web Site. The annual adjustments will be posted on the Department of Labor Web page: [www.ctdol.state.ct.us](http://www.ctdol.state.ct.us). For those without internet access, please contact the division listed below.
- The Department of Labor will continue to issue the initial prevailing wage rate schedule to the Contracting Agency for the project. All subsequent annual adjustments will be posted on our Web Site for contractor access.

**Any questions should be directed to the Contract Compliance Unit, Wage and Workplace Standards Division, Connecticut Department of Labor, 200 Folly Brook Blvd., Wethersfield, CT 06109 at (860)263-6790.**

[Workplace Laws](#)

Published by the Connecticut Department of Labor, Automation Support Unit

~NOTICE~

TO ALL CONTRACTING AGENCIES

Please be advised that Connecticut General Statutes Section 31-53, requires the contracting agency to certify to the Department of Labor, the total dollar amount of work to be done in connection with such public works project, regardless of whether such project consists of one or more contracts.

Please find the attached "Contracting Agency Certification Form" to be completed and returned to the Department of Labor, Wage and Workplace Standards Division, Public Contract Compliance Unit.

 Inquiries can be directed to (860)263-6543.

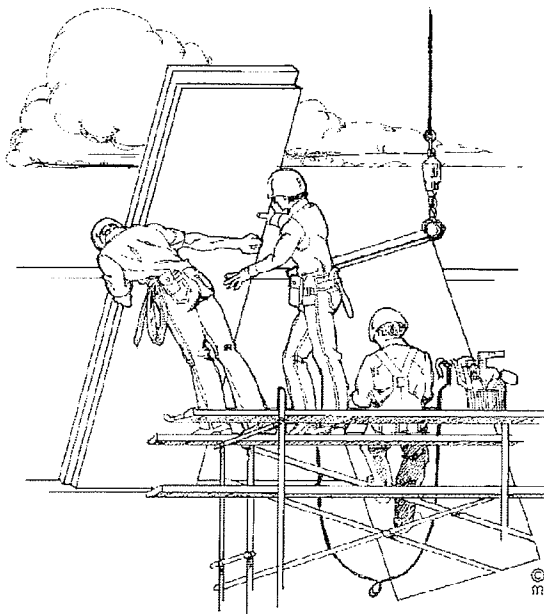

CONNECTICUT DEPARTMENT OF LABOR  
WAGE AND WORKPLACE STANDARDS DIVISION  
CONTRACT COMPLIANCE UNIT

*CONTRACTING AGENCY CERTIFICATION FORM*

I, \_\_\_\_\_, acting in my official capacity as \_\_\_\_\_,  
authorized representative title

for \_\_\_\_\_, located at \_\_\_\_\_,  
contracting agency address

do hereby certify that the total dollar amount of work to be done in connection with

\_\_\_\_\_, located at \_\_\_\_\_,  
project name and number address

shall be \$\_\_\_\_\_, which includes all work, regardless of whether such project  
consists of one or more contracts.

*CONTRACTOR INFORMATION*

Name: \_\_\_\_\_

Address: \_\_\_\_\_

Authorized Representative: \_\_\_\_\_

Approximate Starting Date: \_\_\_\_\_

Approximate Completion Date: \_\_\_\_\_

\_\_\_\_\_  
Signature

\_\_\_\_\_  
Date

Return To: Connecticut Department of Labor  
Wage & Workplace Standards Division  
Contract Compliance Unit  
200 Folly Brook Blvd.  
Wethersfield, CT 06109

Date Issued: \_\_\_\_\_

CONNECTICUT DEPARTMENT OF LABOR  
WAGE AND WORKPLACE STANDARDS DIVISION

**CONTRACTORS WAGE CERTIFICATION FORM**

I, \_\_\_\_\_ of \_\_\_\_\_  
Officer, Owner, Authorized Rep. Company Name

do hereby certify that the \_\_\_\_\_  
Company Name

\_\_\_\_\_  
Street

\_\_\_\_\_  
City

and all of its subcontractors will pay all workers on the

\_\_\_\_\_  
Project Name and Number

\_\_\_\_\_  
Street and City

the wages as listed in the schedule of prevailing rates required for such project (a copy of which is attached hereto).

\_\_\_\_\_  
Signed

Subscribed and sworn to before me this \_\_\_\_\_ day of \_\_\_\_\_, :

\_\_\_\_\_  
Notary Public

 Return to:

Connecticut Department of Labor  
Wage & Workplace Standards Division  
200 Folly Brook Blvd.  
Wethersfield, CT 06109

# Certified Payroll Form WWS - CPI

Last Updated: May 03, 2007

**You are here:** [DOL Web Site](#) » [Wage and Workplace Issues](#) » [Certified Payroll Form WWS - CPI](#)

In accordance with [Connecticut General Statutes, 31-53](#) Certified Payrolls with a statement of compliance shall be submitted monthly to the contracting agency.

**Note:** Once you have downloaded these forms and are ready to print them out, set the print function on your PC to the horizontal print orientation.

**Note2:** Please download both the Payroll Certification for Public Works Projects **and** the Certified Statement of Compliance for a complete package. The Certified Statement of Compliance appears on the same page as the Fringe Benefits Explanation page.

**Announcement: The Certified Payroll Form WWS-CPI can now be completed on-line!**

**[Certified Payroll Form WWS-CPI](#)** (PDF, 439KB)

Published by the Connecticut Department of Labor, Automation Support Unit



**\*FRINGE BENEFITS EXPLANATION (P):**

Bona fide benefits paid to approved plans, funds or programs, except those required by Federal or State Law (unemployment tax, worker's compensation, income taxes, etc.)

Please specify the type of benefits provided:

- 1) Medical or hospital care \_\_\_\_\_
- 2) Pension or retirement \_\_\_\_\_
- 3) Life Insurance \_\_\_\_\_
- 4) Disability \_\_\_\_\_
- 5) Vacation, holiday \_\_\_\_\_
- 6) Other (please specify) \_\_\_\_\_

**CERTIFIED STATEMENT OF COMPLIANCE**

For the week ending date of \_\_\_\_\_,

I, \_\_\_\_\_ of \_\_\_\_\_, (hereafter known as Employer)

in my capacity as \_\_\_\_\_ (title) do hereby certify and state:

All persons employed on said project have been paid the full weekly wages earned by them during the week in accordance with Connecticut General Statutes, section 31-53, as amended. Further, I hereby certify and state the following:

- A) The records submitted are true and accurate;
- B) The rate of wages paid to each mechanic, laborer or workman and the amount of payment or contributions paid or payable on behalf of each such employee to any employee welfare fund, as defined in Connecticut General Statutes, section 31-53 (h), are not less than the prevailing rate of wages and the amount of payment or contributions paid or payable on behalf of each such employee to any employee welfare fund, as determined by the Labor Commissioner pursuant to subsection Connecticut General Statutes, section 31-53 (d), and said wages and benefits are not less than those which may also be required by contract;
- C) The Employer has complied with all of the provisions in Connecticut General Statutes, section 31-53 (and Section 31-54 if applicable for state highway construction);
- D) Each such employee of the Employer is covered by a worker's compensation insurance policy for the duration of his employment which proof of coverage has been provided to the contracting agency;
- E) The Employer does not receive kickbacks, which means any money, fee, commission, credit, gift, gratuity, thing of value, or compensation of any kind which is provided directly or indirectly, to any prime contractor, prime contractor employee, subcontractor, or subcontractor employee for the purpose of improperly obtaining or rewarding favorable treatment in connection with a prime contract or in connection with a prime contractor in connection with a subcontractor relating to a prime contractor; and
- F) The Employer is aware that filing a certified payroll which he knows to be false is a class D felony for which the employer may be fined up to five thousand dollars, imprisoned for up to five years or both.

Submitted on

\_\_\_\_\_  
(Date)

\_\_\_\_\_  
(Signature)

\_\_\_\_\_  
(Title)

**\*\*\*THIS IS A PUBLIC DOCUMENT\*\*\*  
\*\*\*DO NOT INCLUDE SOCIAL SECURITY NUMBERS\*\*\***





# Occupational Classification Bulletin

Last Updated: October 02, 2007

**You are here:** [DOL Web Site](#) › [Wage and Workplace Issues](#) › Occupational Classification Bulletin

- **new** [Informational Bulletin - 10/1/07 \(PDF, 1,572KB\)](#)

Published by the Connecticut Department of Labor, Automation Support Unit

Revised: October 1, 2007

## Informational Bulletin

### *Occupational Classifications*

The Connecticut Department of Labor has the responsibility to properly determine "job classification" on prevailing wage projects covered under C.G.S. Section 31-53.

*✓Note: This information is intended to provide a sample of some occupational classifications for guidance purposes only. It is not an all-inclusive list of each occupation's duties. This list is being provided only to highlight some areas where a contractor may be unclear regarding the proper classification.*

On any construction project, an assortment of workers are needed to carry out all of the required tasks. Employees include various skilled crafts people, machine operators, general laborers, and apprentices. Prevailing wage rate schedules identify the classes of workers likely to be employed on each of the four types of construction projects. (If a contractor wants to use a class of worker not listed in a wage determination, there is a process for requesting the U.S. Department of Labor to establish a prevailing wage rate for that additional classification). (Contact U.S. Department of Labor at 202.693.0062 or 215.861.5800)

A registered apprentice is not a separate prevailing wage job classification. Apprentices are paid a percentage of the base rate received by the craft that they are training to become and the full fringe rate. This percentage increases in steps, as the apprentice advances through the stages of the apprenticeship process.

 Any questions regarding the proper classification should be directed to the Contract Compliance Unit, Wage and Workplace Standards Division, Connecticut Department of Labor, 200 Folly Brook Blvd, Wethersfield, CT 06109 at 860.263.6543.

Below are additional clarifications of specific job duties performed for certain classifications:

⇒ ASBESTOS WORKERS/INSULATORS:

- ▶ Handle, install, apply, fabricate, distribute, prepare, alter, repair, or dismantle heat and frost insulation, including penetration and fire stopping work on all penetration fire stop systems.

⇒ BOILERMAKERS:

- ▶ Erects hydro plants, incomplete vessels, steel stacks, storage tanks for water, fuel, etc. Builds incomplete boilers, repairs heat exchanges and steam generators.

⇒ BRICKLAYERS, CEMENT MASONS, CEMENT FINISHERS, MARBLE MASONS, PLASTERERS, STONE MASONS, PLASTERERS, STONE MASONS, TERRAZZO WORKERS, TILE SETTERS:

- ▶ Lays building materials such as brick, structural tile and concrete cinder, glass, gypsum, terra cotta block. Cuts, tools and sets marble, sets stone, finishes concrete, applies decorative steel, aluminum and plastic tile, applies cements, sand, pigment and marble chips to floors, stairways, etc.

⇒ CARPENTERS, MILLWRIGHTS, PILEDRIVERMEN, LATHERS, RESILIENT FLOOR LAYERS, DOCK BUILDERS, DIVERS, DIVER TENDERS:

- ▶ Constructs, erects, installs and repairs structures and fixtures of wood, plywood and wallboard. Installs, assembles, dismantles, moves industrial machinery. Drives piling into ground to provide foundations for structures such as buildings and bridges, retaining walls for earth embankments, such as cofferdams. Fastens wooden, metal or rockboard lath to walls, ceilings and partitions of buildings, acoustical tile layer, concrete form builder. Applies firestopping materials on fire resistive joint systems only. Installation of curtain/window walls only where attached to wood or metal studs.
- ▶ Assembly and installation of modular furniture/furniture systems.  
[New] a. Free-standing furniture is not covered. This includes: student chairs, study top desks, book box desks, computer furniture, dictionary stand, atlas stand, wood shelving, two- position information access station, file cabinets, storage cabinets, tables, etc.

⇒ CLEANING LABORER:

- ▶ The clean up of any construction debris and the general cleaning, including sweeping, wash down, mopping, wiping of the construction facility, washing, polishing, dusting, etc., prior to the issuance of a certificate of occupancy falls under the *Labor classification*.

☞ continued

⇒DELIVERY PERSONNEL:

- ▶ If delivery of supplies/building materials is to one common point and stockpiled there, prevailing wages are not required. If the delivery personnel are involved in the distribution of the material to multiple locations within the construction site then they would have to be paid prevailing wages for the type of work performed: laborer, equipment operator, electrician, ironworker, plumber, etc.
- ▶ An example of this would be where delivery of drywall is made to a building and the delivery personnel distribute the drywall from one "stockpile" location to further sub-locations on each floor. Distribution of material around a construction site is the job of a laborer/tradesman and not a delivery personnel.

⇒ELECTRICIANS:

- ▶ Install, erect, maintenance, alteration or repair of any wire, cable, conduit, etc., which generates, transforms, transmits or uses electrical energy for light, heat, power or other purposes. **\*License required per Connecticut General Statutes: E-1,2 L-5,6 C-5,6 T-1,2 L-1,2 V-1,2,7,8,9.**

⇒ELEVATOR CONSTRUCTORS:

- ▶ Install, erect, maintenance and repair of all types of elevators, escalators, dumb waiters and moving walks. **\*License required by Connecticut General Statutes: R-1,2,5,6.**

⇒FORK LIFT OPERATOR:

- ▶ Laborers Group 4) Mason Tenders - operates forklift solely to assist a mason to a maximum height of nine (9) feet only.
- ▶ Power Equipment Operator Group 9 - operates forklift to assist any trade, and to assist a mason to a height over nine (9) feet.

⇒GLAZIERS:

- ▶ Installs light metal sash, head sills, and 2-story aluminum storefronts.

⇒IRONWORKERS:

- ▶ Handling, sorting, and installation of reinforcing steel (rebar).
- ▶ Installation of aluminum window walls and curtain walls.
- ▶ Metal bridge rail (traffic), metal bridge handrail, and decorative security fence installation.

⇒INSULATOR:

- ▶ Installing fire stopping systems/materials for "Penetration Firestop Systems": transit to cables, electrical conduits, insulated pipes, sprinkler pipe penetrations, ductwork behind radiation, electrical cable trays, fire rated pipe penetrations, natural polypropylene, HVAC ducts, plumbing bare metal, telephone and communication wires, and boiler room ceilings. Past practice using the applicable licensed trades, Plumber, Sheet Metal, Sprinkler Fitter, and Electrician, is not inconsistent with the Insulator classification and would be permitted.

⇒LEAD PAINT REMOVAL:

- ▶ Painter Rate -
  - 1) Removal of lead paint from bridges.
  - 2) Removal of lead paint as preparation of any surface to be repainted.
  - 3) Where removal is on a *Demolition* project prior to reconstruction.
- ▶ Laborer Rate-
  - 1) Removal of lead paint from any surface *NOT* to be repainted.
  - 2) Where removal is on a *TOTAL* Demolition project only.

⇒LABORERS:

- ▶ Acetylene burners, asphalt rakers, chain saw operators, concrete and power buggy operator, concrete saw operator, fence and guard rail erector, hand operated concrete vibrator operator, mason tenders, pipelayers (installation of water, storm drainage or sewage lines outside of the building line with P6, P7 license), pneumatic drill operator, pneumatic gas and electric drill operator, powermen and wagon drill operator, air track operator, block paver, curb setters, blasters, concrete spreaders.

⇒PAINTERS:

- ▶ Maintenance, preparation, cleaning, blasting (water and sand, etc.), painting or application of any protective coatings of every description on all bridges and appurtenances of highways, roadways, and railroads. Painting, decorating, hardwood finishing, paper hanging, sign writing, scenic art work and drywall finishing for any and all types of building and residential work.

⇒PLUMBERS AND PIPEFITTERS:

- ▶ Installation, repair, replacement, alteration or maintenance of all plumbing, heating, cooling and piping. **\*License required per Connecticut General Statutes: P-1,2,6,7,8,9 J-1,2,3,4 SP-1,2. S-1,2,3,4,5,6,7,8 B-1,2,3,4 D-1,2,3,4.**

⇒POWER EQUIPMENT OPERATORS:

- ▶ Operates several types of power construction equipment such as compressors, pumps, hoists, derricks, cranes, shovels, tractors, scrapers or motor graders, etc. Repairs and maintains equipment. **\*License required, crane operators only, per Connecticut General Statutes.**

☞ continued

⇒ROOFERS:

- ▶ Preparation of surface, tear-off and/or removal of any type of roofing, and/or clean-up of any areas where a roof is to be relaid.

⇒SHEET METAL WORKER:

- ▶ Fabrication, handling, assembling, erecting, altering, repairing, etc. of coated metal material panels and composite metal material panels when used on building exteriors and interiors as soffits, fascia, louvers, partitions, wall panel siding, canopies, cornice, column covers, awnings, beam covers, cladding, sun shades, lighting troughs, spires, ornamental roofing, metal ceilings, mansards, copings, ornamental and ventilation hoods, vertical and horizontal siding panels, trim, etc. The sheet metal classification also applies to the vast variety of coated metal material panels and composite metal material panels that have evolved over the years as an alternative to conventional ferrous and non-ferrous metals like steel, iron, tin, copper, brass, bronze, aluminum, etc. Insulated metal and insulated composite panels are still installed by the Iron Worker. Fabrication, handling, assembling, erecting, altering, repairing, etc. of architectural metal roof, standing seam roof, composite metal roof, metal and composite bathroom/toilet partitions, aluminum gutters, metal and composite lockers and shelving, kitchen equipment, and walk-in coolers.

⇒SPRINKLER FITTERS:

Installation, alteration, maintenance and repair of fire protection sprinkler systems. **\*License required per Connecticut General Statutes: F-1,2,3,4.**

⇒TILE, MARBLE AND TERRAZZO FINISHERS:

Assists and tends the tile setter, marble mason and terrazzo worker in the performance of their duties.

⇒TRUCK DRIVERS:

- ▶ Truck Drivers delivering asphalt are covered under prevailing wage while on the site and directly involved in the paving operation.
- ▶ Material men and deliverymen are not covered under prevailing wage as long as they are not directly involved in the construction process. If, they unload the material, they would then be covered by prevailing wage for the classification they are performing work in: laborer, equipment operator, etc.
- ▶ Hauling material off site is not covered provided they are not dumping it at a location outlined above.
- ▶ Driving a truck on site and moving equipment or materials on site would be considered covered work, as this is part of the construction process.

**CONNECTICUT DEPARTMENT OF LABOR**  
**Wage and Workplace Standards Division**

**FOOTNOTES**

Please Note: If the "Benefits" listed on the schedule for the following occupations includes a letter(s) (+ a or + a+b for instance), refer to the information below.

Benefits to be paid at the appropriate prevailing wage rate for the listed occupation.

If the "Benefits" section for the occupation lists only a dollar amount, disregard the information below.

**Bricklayers, Cement Masons, Cement Finishers, Plasters, Stone Masons**  
(Building Construction)  
(Residential- Hartford, Middlesex, New Haven, New London and Tolland Counties)

a. Paid Holiday: Employees shall receive 4 hours for Christmas Eve holiday provided the employee works the regularly scheduled day before and after the holiday. Employees may schedule work on Christmas Eve and employees shall receive pay for actual hours worked in addition to holiday pay.

**Bricklayer (Residential- Fairfield County)**

a. Paid Holiday: If an employee works on Christmas Eve until noon he shall be paid for 8 hours.

**Electricians**

Fairfield County: West of the Five Mile River in Norwalk

a. \$2.00 per hour not to exceed \$14.00 per day.

**Elevator Constructors: Mechanics**

- a. Paid Holidays: New Year's Day, Memorial Day, Independence Day, Labor Day, Thanksgiving Day, Christmas Day, plus the Friday after Thanksgiving.
- b. Vacation: Employer contributes 8% of basic hourly rate for 5 years or more of service or 6% of basic hourly rate for 6 months to 5 years of service as vacation pay credit.



### **Glaziers**

- a. Paid Holidays: Labor Day and Christmas Day.

### **Power Equipment Operators**

(Heavy and Highway Construction & Building Construction)

- a. Paid Holidays: New Year's Day, Good Friday, Memorial day, Independence Day, Labor Day, Thanksgiving Day and Christmas Day, provided the employee works 3 days during the week in which the holiday falls, if scheduled, and if scheduled, the working day before and the working day after the holiday. Holidays falling on Saturday may be observed on Saturday, or if the employer so elects, on the preceding Friday.

### **Ironworkers**

- a. Paid Holiday: Labor Day provided employee has been on the payroll for the 5 consecutive workdays prior to Labor Day.

### **Laborers (Tunnel Construction)**

- a. Paid Holidays: New Year's Day, Memorial Day, Independence Day, Labor Day, Thanksgiving Day and Christmas Day. No employee shall be eligible for holiday pay when he fails, without cause, to work the regular workday preceding the holiday or the regular workday following the holiday.

### **Roofers**

- a. Paid Holidays: July 4<sup>th</sup>, Labor Day, and Christmas Day provided the employee is employed 15 days prior to the holiday.

### **Sprinkler Fitters**

- a. Paid Holidays: Memorial Day, July 4th, Labor Day, Thanksgiving Day and Christmas Day, provided the employee has been in the employment of a contractor 20 working days prior to any such paid holiday.

### **Truck Drivers**

(Heavy and Highway Construction & Building Construction)

- a. Paid Holidays: New Year's Day, Memorial Day, Independence Day, Labor Day, Thanksgiving Day, Christmas day, and Good Friday, provided the employee has at least 31 days service and works the last scheduled day before and the first scheduled day after the holiday.

**EXHIBIT G**

To

**REFURBISHMENT OF  
PRIMARY SHREDDERS CV-104/204 AT THE MID-  
CONNECTICUT WASTE PROCESSING FACILITY  
AGREEMENT**

**SCHEDULE OF PREVAILING WAGES**

**Project Refurbishment Of Primary Shredders At The Mid Connecticut Waste Processing Facility**

**Minimum Rates and Classifications  
for Building Construction**

**B 10111**

**Connecticut Department of Labor  
Wage and Workplace Standards Division**

By virtue of the authority vested in the Labor Commissioner under provisions of Section 31-53 of the General Statutes of Connecticut, as amended, the following are declared to be the prevailing rates and welfare payments and will apply only where the contract is advertised for bid within 20 days of the date on which the rates are established. Any contractor or subcontractor not obligated by agreement to pay to the welfare and pension fund shall pay this amount to each employee as part of his/her hourly wages.

**Project Number CV-014/204**

**Project Town Hartford**

**Project Refurbishment Of Primary Shredders At The Mid Connecticut Waste Processing Facility**

<b>CLASSIFICATION</b>	<b>Hourly Rate</b>	<b>Benefits</b>
1a) Asbestos Worker/Insulator (Includes application of insulating materials, protective coverings, coatings, & finishes to all types of mechanical systems; application of firestopping material for wall openings & penetrations in walls, floors, ceilings.	28.86	16.83
1b) Asbestos/Toxic Waste Removal Laborers: Asbestos removal and encapsulation (except its removal from mechanical systems which are not to be scrapped), toxic waste removers, blasters. **See Laborers Group 7**		
1c) Hazardous Material Handler: Includes preparation, wetting, stripping, removal, scrapping, vacuuming, bagging and disposing of all insulation materials, whether they contain asbestos or not, from mechanical systems.	20.50	10.30
2) Boilermaker	31.65	8.72 + 32%
3a) Bricklayer, Cement Mason, Cement Finishers, Plasterers, Stone Masons	30.25	17.25 + a
3b) Tile Setter	29.34	15.61

**As of: Tuesday, October 16, 2007**

**Project Refurbishment Of Primary Shredders At The Mid Connecticut Waste Processing Facility**

3c) Terrazzo Workers, Marble Setters	29.59	17.36
3d) Tile, Marble & Terrazzo Finishers	23.90	13.53
-----LABORERS-----		
4) Group 1: Laborers, carpenter tenders, wrecking laborers, fire watchers.	23.00	13.40
4a) Group 2: Mortar mixers, plaster tenders, power buggy operators, powdermen, fireproofers/mixer/nozzleman.	23.25	13.40
4b) Group 3: Jackhammer operators, mason tenders.	23.50	13.40
4c) **Group 4: Pipelayers (Installation of water, storm drainage or sewage lines outside of the building line with P6, P7 license) [If using this classification call the Labor Department for clarification]	23.85	13.40
4d) Group 5: Air track operators, Sand blasters.	23.75	13.40
4e) Group 6: Nuclear toxic waste removers, blasters.	26.00	13.40
4f) Group 7: Asbestos removal and encapsulation (except it's removal from mechanical systems which are not to be scrapped).	24.00	13.40

*As of:* **Tuesday, October 16, 2007**

**Project Refurbishment Of Primary Shredders At The Mid Connecticut Waste Processing Facility**

4g) Group 8: Bottom men on open air caisson, cylindrical work and boring crew.	23.50	13.40
4h) Group 9: Top men on open air caisson, cylindrical work and boring crew.	23.00	13.40
5) Carpenter, Acoustical Tile Worker, Concrete Form-Wood Builder, Floor Covering (Including Drywall Hanging), Modular-Furniture Systems Installers.	26.65	16.21
5a) Millwrights	27.40	16.21
6) Electrical Worker, Cable Splicer (electric) (Trade License required: E1,2 L-5,6 C-5,6 T-1,2 L-1,2 V-1,2,7,8,9)	33.10	18.02
7a) Elevator Mechanic (Trade License required: R-1,2,5,6)	39.595	14.885+a+b
8) Glazier (Trade License required: FG-1,2)	30.38	13.10 + a
9) Ironworker, Ornamental, Reinforcing, Structural, and Precast Concrete Erection	31.05	21.18 + a
----OPERATORS----		
Group 1: Crane handling or erecting structural steel or stone, hoisting engineer 2 drums or over, front end loader (7 cubic yards or over); work boat 26 ft. and over.	32.05	16.05 + a

*As of:* **Tuesday, October 16, 2007**

**Project Refurbishment Of Primary Shredders At The Mid Connecticut Waste Processing Facility**

Group 2: Cranes (100 ton rated capacity & over), backhoe over 2 cubic yards, piledriver (\$3.00 premium when operator controls hammer).	31.73	16.05 + a
Group 3: Backhoe, cranes (under 100 ton rated capacity), gradall, master mechanic, hoisting engineer (all types of equipment where a drum and cable are used to hoist, pull or drag material regardless of motive power of operation); rubber tire backhoe	30.99	16.05 + a
Group 4: Trenching machines; lighter derrick; CMI Machine or similar; Koehring Loader (skoooper).	30.60	16.05 + a
Group 5: Specialty Railroad Equipment; Asphalt Spreader; Asphalt Reclaiming Machine; Line Grinder; Concrete pumps; drills with self contained power units; Boring machine; Post hole digger; Auger; Pounder; Well Digger	30.01	16.05 + a
Group 5 continued: Milling machine (over 24" Mandrell); Side Boom; Combination hoe and loader; Directional driller; Grader.	30.01	16.05 + a
Group 6: Front end loader (3 up to 7 cubic yards); Bulldozer.	29.70	16.05 + a
Group 7: Asphalt roller, concrete saws and cutters (ride on types), vermeer concrete cutter, Stump Grinder; Scraper; Snooper; Skidder; Milling Machine (24" and under Mandrell).	29.36	16.05 + a
Group 8: Mechanic, grease truck operator, hydroblaster; barrier mover; power stone spreader; welding; work boat under 26 ft.; transfer machine.	28.96	16.05 + a
Group 9: Front end loader (under 3 cubic yards), skid steer loader regardless of attachments, (Bobcat or Similar): forklift, power chipper; landscape equipment (including Hydroseeder).	28.53	16.05 + a
Group 10: Vibratory hammer; ice machine; diesel and air, hammer, etc.	27.96	16.05 + a

*As of: Tuesday, October 16, 2007*

**Project Refurbishment Of Primary Shredders At The Mid Connecticut Waste Processing Facility**

Group 11: Conveyor, earth roller, power pavement breaker (whiphammer), robot demolition equipment.	26.49	16.05 + a
Group 12: Wellpoint operator.	26.43	16.05 + a
Group 13: Compressor battery operator.	25.85	16.05 + a
Group 14: Elevator operator; tow motor operator (solid tire no rough terrain).	24.71	16.05 + a
Group 15: Generator operator, compressor operator, pump operator, welding machine operator.	24.30	16.05 + a
Group 16: Maintenance engineer.	23.65	16.05 + a
Group 17: Portable asphalt plant operator; portable crusher plant operator; portable concrete plant operator	25.98	16.05 + a
Group 18: Power safety boat; vacuum truck; zim mixer; sweeper	25.54	16.05 + a

-----PAINTERS (Including Drywall Finishing)-----

10a) Brush, Roller	26.87	13.10
--------------------	-------	-------

*As of: Tuesday, October 16, 2007*

**Project Refurbishment Of Primary Shredders At The Mid Connecticut Waste Processing Facility**

10b) Taper	27.62	13.10
10c) Paperhanger	27.37	13.10
10d) Red Label	27.37	13.10
10e) Blast and Spray	29.87	13.10
10f) Tanks, Tower, Swingstage	28.87	13.10
11) Plumber P-1,2,6,7,8,9 J-1,2,3,4 SP-1,2)	(Trade License required: 33.57	18.96
12) Post Digger, Well Digger, Pile Testing Machine	25.25	9.05 + a
13) Roofer (composition)	28.40	13.25
14) Roofer (slate & tile)	28.90	13.25
15) Sheetmetal Worker (Trade License required for HVAC and Ductwork: SM-1,SM-2,SM-3,SM-4,SM-5,SM-6)	29.55	23.15

*As of:* Tuesday, October 16, 2007



**Project Refurbishment Of Primary Shredders At The Mid Connecticut Waste Processing Facility**

16) Pipefitter (Including HVAC work) (Trade License required: S-1,2,3,4,5,6,7,8 B-1,2,3,4 D-1,2,3,4, G-1, G-2, G-8 & G-9)	33.57	18.96
---	-------	-------

-----TRUCK DRIVERS-----

17a) 2 Axle	25.43	11.5225
-------------	-------	---------

17b) 3 Axle, 2 Axle Ready Mix	25.53	11.5225
-------------------------------	-------	---------

17c) 3 Axle Ready Mix	25.58	11.5225
-----------------------	-------	---------

17d) 4 Axle, Heavy Duty Trailer up to 40 tons	25.63	11.5225
---	-------	---------

17e) 4 Axle Ready Mix	25.68	11.5225
-----------------------	-------	---------

17f) Heavy Duty Trailer (40 Tons and Over)	25.88	11.5225
--	-------	---------

17g) Specialized Earth Moving Equipment (Other Than Conventional Type on-the-Road Trucks and Semi-Trailers, Including Euclids)	25.68	11.5225
--	-------	---------

18) Sprinkler Fitter (Trade License required: F-1,2,3,4)	36.50	15.10 + a
--	-------	-----------

*As of: Tuesday, October 16, 2007*

**Project Refurbishment Of Primary Shredders At The Mid Connecticut Waste Processing Facility**

*Welders: Rate for craft to which welding is incidental.*

*\*Note: Hazardous waste removal work receives additional \$1.50 per hour for power equipment operators and \$1.25 per hour for truck drivers.*

*\*\*Note: Hazardous waste premium \$1.50 per hour over classified rate*

Crane with 150 ft. boom (including jib) - \$.75 extra  
Crane with 200 ft. boom (including jib) - \$1.25 extra  
Crane with 250 ft. boom (including jib) - \$2.50 extra  
Crane with 300 ft. boom (including jib) - \$3.50 extra  
Crane with 400 ft. boom (including jib) - \$4.00 extra  
Crane with 500 ft. boom (including jib) - \$5.00 extra

**All classifications that indicate a percentage of the fringe benefits must be calculated at the percentage rate times the "base hourly rate".**

**Apprentices duly registered under the Commissioner of Labor's regulations on "Work Training Standards for Apprenticeship and Training Programs" Section 31-51-d-1 to 12, are allowed to be paid the appropriate percentage of the prevailing journeymen hourly base and the full fringe benefit rate, providing the work site ratio shall not be less than one full-time journeyman instructing and supervising the work of each apprentice in a specific trade.**

*The Prevailing wage rates applicable to this project are subject to annual adjustments each July 1st for the duration of the project.*

*Each contractor shall pay the annual adjusted prevailing wage rate that is in effect each July 1st, as posted by the Department of Labor.*

*It is the contractor's responsibility to obtain the annual adjusted prevailing wage rate increases directly from the Department of Labor's website.*

*The annual adjustments will be posted on the Department of Labor's Web page: [www.ct.gov/dol](http://www.ct.gov/dol)*

*The Department of Labor will continue to issue the initial prevailing wage rate schedule to the Contracting Agency for the project.*

*All subsequent annual adjustments will be posted on our Web Site for contractor access.*

**As of: Tuesday, October 16, 2007**

**Project Refurbishment Of Primary Shredders At The Mid Connecticut Waste Processing Facility**

*Effective October 1, 2005 - Public Act 05-50: any person performing the work of any mechanic, laborer, or worker shall be paid prevailing wage*

All Person who perform work ON SITE must be paid prevailing wage for the appropriate mechanic, laborer, or worker classification.

All certified payrolls must list the hours worked and wages paid to All Persons who perform work ON SITE regardless of their ownership i.e.: (Owners, Corporate Officers, LLC Members, Independent Contractors, et. al)

Reporting and payment of wages is required regardless of any contractual relationship alleged to exist between the contractor and such person.

Please direct any questions which you may have pertaining to classification of work and payment of prevailing wages to the Wage and Workplace Standards Division, telephone (860)263-6790.

*As of: Tuesday, October 16, 2007*

**EXHIBIT H**

To

**REFURBISHMENT OF  
PRIMARY SHREDDERS CV-104/204 AT THE MID-  
CONNECTICUT WASTE PROCESSING FACILITY  
AGREEMENT**

**SEEC FORM 11  
NOTICE TO EXECUTIVE BRANCH STATE  
CONTRACTORS AND PROSPECTIVE STATE  
CONTRACTORS OF CAMPAIGN CONTRIBUTION  
AND SOLICITATION BAN**

**SEEC FORM 11**

**NOTICE TO EXECUTIVE BRANCH STATE CONTRACTORS AND PROSPECTIVE STATE CONTRACTORS OF CAMPAIGN CONTRIBUTION AND SOLICITATION BAN**

This notice is provided under the authority of Connecticut General Statutes 9-612(g)(2), as amended by P.A. 07-1, and is for the purpose of informing state contractors and prospective state contractors of the following law (italicized words are defined on the following page):

**Campaign Contribution and Solicitation Ban**

No *state contractor, prospective state contractor, principal of a state contractor or principal of a prospective state contractor*, with regard to a *state contract or state contract solicitation* with or from a state agency in the executive branch or a quasi-public agency or a holder, or principal of a holder of a valid prequalification certificate, shall make a contribution to, or *solicit* contributions on behalf of (i) an exploratory committee or candidate committee established by a candidate for nomination or election to the office of Governor, Lieutenant Governor, Attorney General, State Comptroller, Secretary of the State or State Treasurer, (ii) a political committee authorized to make contributions or expenditures to or for the benefit of such candidates, or (iii) a party committee;

In addition, no holder or principal of a holder of a valid prequalification certificate, shall make a contribution to, or solicit contributions on behalf of (i) an exploratory committee or candidate committee established by a candidate for nomination or election to the office of State senator or State representative, (ii) a political committee authorized to make contributions or expenditures to or for the benefit of such candidates, or (iii) a party committee.

**Duty to Inform**

State contractors and prospective state contractors are required to inform their principals of the above prohibitions, as applicable, and the possible penalties and other consequences of any violation thereof.

**Penalties for Violations**

Contributions or solicitations of contributions made in violation of the above prohibitions may result in the following civil and criminal penalties:

Civil penalties--\$2000 or twice the amount of the prohibited contribution, whichever is greater, against a principal or a contractor. Any state contractor or prospective state contractor which fails to make reasonable efforts to comply with the provisions requiring notice to its principals of these prohibitions and the possible consequences of their violations may also be subject to civil penalties of \$2000 or twice the amount of the prohibited contributions made by their principals.

Criminal penalties—Any knowing and willful violation of the prohibition is a Class D felony, which may subject the violator to imprisonment of not more than 5 years, or \$5000 in fines, or both.

**Contract Consequences**

Contributions made or solicited in violation of the above prohibitions may result, in the case of a state contractor, in the contract being voided.

Contributions made or solicited in violation of the above prohibitions, in the case of a prospective state contractor, shall result in the contract described in the state contract solicitation not being awarded to the prospective state contractor, unless the State Elections Enforcement Commission determines that mitigating circumstances exist concerning such violation.

The State will not award any other state contract to anyone found in violation of the above prohibitions for a period of one year after the election for which such contribution is made or solicited, unless the State Elections Enforcement Commission determines that mitigating circumstances exist concerning such violation.

Additional information and the entire text of P.A 07-1 may be found on the website of the State Elections Enforcement Commission, [www.ct.gov/seec](http://www.ct.gov/seec). Click on the link to "State Contractor Contribution Ban."

Definitions:

"State contractor" means a person, business entity or nonprofit organization that enters into a state contract. Such person, business entity or nonprofit organization shall be deemed to be a state contractor until December thirty-first of the year in which such contract terminates. "State contractor" does not include a municipality or any other political subdivision of the state, including any entities or associations duly created by the municipality or political subdivision exclusively amongst themselves to further any purpose authorized by statute or charter, or an employee in the executive or legislative branch of state government or a quasi-public agency, whether in the classified or unclassified service and full or part-time, and only in such person's capacity as a state or quasi-public agency employee.

"Prospective state contractor" means a person, business entity or nonprofit organization that (i) submits a response to a state contract solicitation by the state, a state agency or a quasi-public agency, or a proposal in response to a request for proposals by the state, a state agency or a quasi-public agency, until the contract has been entered into, or (ii) holds a valid prequalification certificate issued by the Commissioner of Administrative Services under section 4a-100. "Prospective state contractor" does not include a municipality or any other political subdivision of the state, including any entities or associations duly created by the municipality or political subdivision exclusively amongst themselves to further any purpose authorized by statute or charter, or an employee in the executive or legislative branch of state government or a quasi-public agency, whether in the classified or unclassified service and full or part-time, and only in such person's capacity as a state or quasi-public agency employee.

"Principal of a state contractor or prospective state contractor" means (i) any individual who is a member of the board of directors of, or has an ownership interest of five per cent or more in, a state contractor or prospective state contractor, which is a business entity, except for an individual who is a member of the board of directors of a nonprofit organization, (ii) an individual who is employed by a state contractor or prospective state contractor, which is a business entity, as president, treasurer or executive vice president, (iii) an individual who is the chief executive officer of a state contractor or prospective state contractor, which is not a business entity, or if a state contractor or prospective state contractor has no such officer, then the officer who duly possesses comparable powers and duties, (iv) an officer or an employee of any state contractor or prospective state contractor who has *managerial or discretionary responsibilities with respect to a state contract*, (v) the spouse or a *dependent child* who is eighteen years of age or older of an individual described in this subparagraph, or (vi) a political committee established or controlled by an individual described in this subparagraph or the business entity or nonprofit organization that is the state contractor or prospective state contractor.

"State contract" means an agreement or contract with the state or any state agency or any quasi-public agency, let through a procurement process or otherwise, having a value of fifty thousand dollars or more, or a combination or series of such agreements or contracts having a value of one hundred thousand dollars or more in a calendar year, for (i) the rendition of services, (ii) the furnishing of any goods, material, supplies, equipment or any items of any kind, (iii) the construction, alteration or repair of any public building or public work, (iv) the acquisition, sale or lease of any land or building, (v) a licensing arrangement, or (vi) a grant, loan or loan guarantee. "State contract" does not include any agreement or contract with the state, any state agency or any quasi-public agency that is exclusively federally funded, an education loan or a loan to an individual for other than commercial purposes.

"State contract solicitation" means a request by a state agency or quasi-public agency, in whatever form issued, including, but not limited to, an invitation to bid, request for proposals, request for information or request for quotes, inviting bids, quotes or other types of submittals, through a competitive procurement process or another process authorized by law waiving competitive procurement.

"Managerial or discretionary responsibilities with respect to a state contract" means having direct, extensive and substantive responsibilities with respect to the negotiation of the state contract and not peripheral, clerical or ministerial responsibilities.

"Dependent child" means a child residing in an individual's household who may legally be claimed as a dependent on the federal income tax of such individual.

"Solicit" means (A) requesting that a contribution be made, (B) participating in any fund-raising activities for a candidate committee, exploratory committee, political committee or party committee, including, but not limited to, forwarding tickets to potential contributors, receiving contributions for transmission to any such committee or bundling contributions, (C) serving as chairperson, treasurer or deputy treasurer of any such committee, or (D) establishing a political committee for the sole purpose of soliciting or receiving contributions for any committee. Solicit does not include: (i) making a contribution that is otherwise permitted by Chapter 155 of the Connecticut General Statutes; (ii) informing any person of a position taken by a candidate for public office or a public official, (iii) notifying the person of any activities of, or contact information for, any candidate for public office; or (iv) serving as a member in any party committee or as an officer of such committee that is not otherwise prohibited in this section.