



**REQUEST FOR BIDS
("RFB")**

FOR

**REFURBISHMENT OF BELT CONVEYORS CV-123/223
AT THE
MID-CONNECTICUT WASTE PROCESSING FACILITY
(RFB Number FY09-OP-009)**

BID DUE DATE: DECEMBER 22, 2008

**Connecticut Resources Recovery Authority
100 Constitution Plaza, 6th Floor
Hartford, Connecticut 06103-1722**

November 24, 2008

REQUEST FOR BIDS
For
REFURBISHMENT OF BELT CONVEYORS CV-123/223
AT THE
MID-CONNECTICUT WASTE PROCESSING FACILITY
(RFB Number FY09-OP-009)

Connecticut Resources Recovery Authority
100 Constitution Plaza, 6th Floor
Hartford, Connecticut 06103-1722

TABLE OF CONTENTS

1. Notice To Contractors – Invitation To Bid
2. Instructions To Bidders
3. Bid Bond Form
4. Bid Form
5. Bid Price Form
6. References Form
7. Background And Experience Form
8. Subcontractor Identification Form
9. Questionnaire Concerning Affirmative Action, Small Business Contractors And Occupational Health And Safety
10. Certification Concerning Nondiscrimination
11. Background Questionnaire
12. SEEC Form 11, Notice To Executive Branch State Contractors And Prospective State Contractors Of Campaign Contribution And Solicitation Ban
13. Notice Of Award
 - A. Contractor's Certification Concerning Gifts [To be executed by successful bidder]
14. Notice To Proceed
15. Refurbishment of Belt Conveyors CV-123/223 At The Mid-Connecticut Waste Processing Facility Agreement
 - A. Project Specifications
 - B. Drawings
 - C. Project Schedule
 - D. Compensation Schedule
 - E. Performance Bond Form and Performance Letter Of Credit Form
 - F. Payment Bond Form (Included only for installation part of the Work)
 - G. Prevailing Wage Bid Package
 - H. Schedule Of Prevailing Wages
 - I. SEEC Form 11, Notice To Executive Branch State Contractors And Prospective State Contractors Of Campaign Contribution And Solicitation Ban
 - J. Certification Concerning Nondiscrimination
 - K. Contractor's Certification Concerning Gifts
 - L. CRRA President's Certification Concerning Gifts

**REQUEST FOR BIDS
FOR
REFURBISHMENT OF BELT CONVEYORS CV-123/223
AT THE
MID-CONNECTICUT WASTE PROCESSING FACILITY**

SECTION 1

**NOTICE TO CONTRACTORS
INVITATION TO BID**

CONNECTICUT RESOURCES RECOVERY AUTHORITY

NOTICE TO CONTRACTORS – INVITATION TO BID

The Connecticut Resources Recovery Authority (“CRRA”) is a quasi-public entity of the State of Connecticut that is responsible for implementing the State Solid Waste Management Plan and is currently providing solid waste disposal and recycling services to more than 100 municipalities in the state. One of CRRA’s facilities is the Mid-Connecticut Resource Recovery Facility (the “RRF”), which is a waste-to-energy facility. The Mid-Connecticut RRF includes the Waste Processing Facility (“WPF”), which is located at 300 Maxim Road, Gate 70, Hartford, Connecticut 06114. The WPF is the facility where Municipal Solid Waste (“MSW”) is converted into Refuse Derived Fuel (“RDF”). The WPF is operated by the Metropolitan District (the “District” or “MDC”) under contract to CRRA.

CRRA is seeking bids from qualified contractors to furnish all tools, materials, labor, equipment and incidentals thereto for refurbishing belt conveyors CV-123/223 at the WPF. CRRA has divided the work into two parts:

- a) Providing the parts necessary for refurbishment of belt conveyor CV-123/223, including, but not limited to, delivering the parts to the WPF; and
- b) Installing the parts necessary to refurbish belt conveyor CV-123/223.

Qualified contractors may bid on the “parts” portion of the work (item a above) or on the “installation” portion of the work (item b above) or on both the parts and installation portions of the work.

Both the “parts” and the “installation” portions of the work will be subject to Connecticut’s prevailing wage requirements, regardless of whether or not the two portions of the work are awarded by CRRA to different contractors.

Request For Bid (“RFB”) package documents may be obtained on the World Wide Web at <http://www.crra.org> under the “Business Opportunities” page beginning **Monday, November 24, 2008**. The documents will also be available Monday through Friday, from 8:30 a.m. to 5:00 p.m. at the offices of CRRA, 100 Constitution Plaza, 6th Floor, Hartford, Connecticut 06103-1722, beginning on the same date. Anyone intending to pick up the documents at CRRA’s offices must contact Ms. Diane Goins [(860) 757-7700] at least 24 hours in advance.

There will be a mandatory pre-bid conference and tour of the site for all prospective bidders. **The mandatory pre-bid conference and tour will be held at the WPF at 10:00 a.m., Wednesday, December 3, 2008.** Any prospective bidder intending to participate in the tour must contact Mr. Richard Kowalski, Operations Engineer, at (860) 559-9478 at least 24 hours in advance of the pre-bid conference and site tour.

Sealed bids must be received at the offices of CRRA, 100 Constitution Plaza, 6th Floor, Hartford, Connecticut 06103-1722 no later than 3:00 p.m., Monday, December 22, 2008. Bids received after the time and date set forth above shall be rejected. All bids shall remain open for ninety (90) days after the bid due date. Bid security will be required.

Bids will be opened at CRRA's convenience on or after the bid due date. Note that all information submitted by a firm responding to this RFB is subject to the Freedom of Information Act.

All questions regarding this RFB must be submitted **in writing** to Ronald Gingerich by e-mail (rgingerich@crra.org), by fax ((860) 757-7742), or by correspondence (CRRA, 100 Constitution Plaza, 6th Floor, Hartford, Connecticut 06103) no later than 3:00 p.m., Monday, December 8, 2008. Any firm considering submitting a bid is prohibited from having any ex-parte communications with any CRRA staff member or CRRA Board member except Mr. Kowalski and Mr. Gingerich.

**REQUEST FOR BIDS
FOR
REFURBISHMENT OF BELT CONVEYORS CV-123/223
AT THE
MID-CONNECTICUT WASTE PROCESSING FACILITY**

**SECTION 2
INSTRUCTIONS TO BIDDERS**

INSTRUCTIONS TO BIDDERS

REFURBISHMENT OF BELT CONVEYORS CV-123/223 AT THE MID-CONNECTICUT WASTE PROCESSING FACILITY

CONTENTS

1. Introduction	1
2. RFB Projected Timeline	2
3. Definitions	2
4. Communications With CRRA Staff and Board Members	4
5. Scope Of Work.....	4
6. Availability of RFB Package Documents	5
7. Mandatory Pre-Bid Conference And Site Tour	6
8. Addenda And Interpretations	6
9. Bid Submittal Procedures	7
10. Bid Security	8
11. Bid Contents	9
12. Bid Opening	10
13. Bid Evaluation	10
14. Contract Award	11
15. Contractor's Certification Concerning Gifts	11
16. Prevailing Wage Requirements	11
17. Department Of Consumer Protection Licensing Requirements	11
18. Bidder's Qualifications	12
19. Bid Preparation And Other Costs	12

1. Introduction

The Connecticut Resources Recovery Authority (“CRRA”) is a quasi-public entity of the State of Connecticut that is responsible for implementing the State Solid Waste Management Plan and is currently providing solid waste disposal and recycling services to more than 100 municipalities in the state. CRRA has developed, constructed and now operates an integrated system of four resources recovery facilities, two regional recycling centers, five landfills (three of which are closed) and twelve transfer stations. At present, CRRA accepts more than 75% of the municipal solid waste generated in the State. These facilities are operated by entities that are under contract with CRRA.

One of CRRA’s facilities is the Mid-Connecticut Resource Recovery Facility (“RRF”), which is a waste-to-energy facility. The Mid-Connecticut RRF includes the Waste Processing Facility (“WPF”), which is the facility where Municipal Solid Waste (“MSW”) is converted into Refuse Derived Fuel (“RDF”). The WPF is located at 300 Maxim Road, Gate 70, Hartford, Connecticut 06114 and is operated by the Metropolitan District (the “District” or “MDC”) under contract to CRRA.

CRRA is seeking bids from qualified contractors to furnish all labor, incidentals and miscellaneous materials thereto for the refurbishment of belt conveyors CV-123/223 at the WPF. CRRA has divided the work into two parts:

- (a) Providing the parts necessary for refurbishment of belt conveyor CV-123/223, including, but not limited to, delivering the parts to the WPF; and
- (b) Installing the parts necessary to refurbish belt conveyor CV-123/223.

Qualified contractors may bid on the “parts” portion of the work (item a above) or on the “installation” portion of the work (item b above) or on both the “parts” and the “installation” portions of the work. It is CRRA’s intention to select the bidder or combination of bidders that is in CRRA’s best interest.

2. RFB Projected Timeline

The following is the projected timeline for the RFB process:

ITEM	DATE
RFP Documents Available	Monday, November 24, 2008
Mandatory Pre-Bid Conference and Site Tour	10:00 a.m., Wednesday, December 3, 2008
Deadline for Written Questions	3:00 p.m., Monday, December 8, 2008
Response to Written Questions	No Later Than Monday, December 17, 2008
Bids Due at CRRA	3:00 p.m., Monday, December 22, 2008
Selection and Notice of Award Issued	Friday, January 23, 2009

CRRA reserves the right at its sole and absolute discretion to extend any of the actual or proposed dates in the above Projected Timeline and further reserves the right to reject any and all bids and republish this RFB. CRRA also reserves the right at its sole and absolute discretion to terminate this RFB process at any time prior to the execution of any Agreement.

Bidders should be aware that it may take up to four weeks from the time the successful bidder returns the executed Agreements to CRRA and meets all of the other conditions specified in the Notice Of Award until CRRA issues to the successful bidder a Notice To Proceed with the work for which it has been selected.

3. Definitions

As used in this Instructions To Bidders and in other Contract Documents (as defined herein), the following terms shall have the meanings as set forth below:

- (a) **Addenda:** Written or graphic documents issued prior to the bid due date that clarify, correct or change any or all of the Contract Documents.
- (b) **Contract Documents:**
 - (1) Refurbishment Of Belt Conveyors CV-123/223 At The Mid-Connecticut Waste Processing Facility Agreement (the “Agreement”);
 - (2) RFB Package Documents (defined in (g) below);
 - (3) Addenda;
 - (4) Contractor’s Bid (including all documentation attached to or accompanying such Bid, all other documentation submitted in connection with such Bid, and all post-bid documentation submitted prior to the Notice Of Award);
 - (5) Notice Of Award, with Contractor Certification Concerning Gifts attached [to be executed by successful bidder]; and
 - (6) Any written amendments to the Agreement.
- (c) **Laws And Regulations:** Any and all applicable laws, rules, regulations, ordinances, codes, orders and permits of any and all federal, state and local governmental and quasi-governmental bodies, agencies, authorities and courts having jurisdiction.
- (d) **Notice Of Award:** Written notification from CRRA to the apparent successful bidder that states that CRRA has accepted such bidder’s bid and sets forth the remaining conditions that must be fulfilled by such bidder before CRRA executes the Agreement.
- (e) **Project:** The provision by the successful bidder of the refurbishment of belt conveyors CV-123/223 at the Mid-Connecticut Waste Processing Facility, in accordance with the Contract Documents.
- (f) **Property:** The certain parcel of real property located at 300 Maxim Road, Gate 70, Hartford, Connecticut 06114, upon which property CRRA operates the Mid-Connecticut Waste Processing Facility.
- (g) **RFB Package Documents:**
 - (1) Notice To Contractors – Invitation To Bid;
 - (2) Instructions To Bidders;
 - (3) Bid Bond Form;
 - (4) Bid Form;
 - (5) Bid Price Form;
 - (6) References Form;
 - (7) Background And Experience Form;
 - (8) Subcontractor Identification Form;
 - (9) Questionnaire Concerning Affirmative Action, Small Business Contractors And Occupational Health And Safety

- (10) Certification Concerning Nondiscrimination;
- (11) Background Questionnaire
- (12) SEEC Form 11, Notice To Executive Branch State Contractors And Prospective State Contractors Of Campaign Contribution And Solicitation Ban;
- (13) Notice Of Award, with Contractor Certification Concerning Gifts attached [to be executed by successful bidder];
- (14) Notice To Proceed; and
- (15) Refurbishment Of Belt Conveyors CV-123/223 At The Mid-Connecticut Resource Recovery Facility Agreement, including:
 - A. Project Specifications;
 - B. Drawings
 - C. Project Schedule;
 - D. Compensation Schedule;
 - E. Performance Bond Form and Performance Letter Of Credit Form
 - F. Payment Bond Form (Included only for “installation” part of the Work)
 - G. Prevailing Wage Bid Package
 - H. Schedule Of Prevailing Wages
 - I. SEEC Form 11, Notice To Executive Branch State Contractors And Prospective State Contractors Of Campaign Contribution And Solicitation Ban;
 - J. Certification Concerning Nondiscrimination;
 - K. Contractor’s Certification Concerning Gifts; and
 - L. President’s Certification Concerning Gifts.

(h) **Site:** Those areas of the Property upon which any of the Work is to be performed, furnished and completed by the successful bidder in accordance with the Contract Documents.

Terms used, but not defined, in this Instructions To Bidders shall have the same respective meanings assigned to such terms in the Agreement.

4. Communications With CRRA Staff and Board Members

Except as otherwise authorized by this Instructions To Bidders, during the period while the RFB process is active (i.e., from the date CRRA issues the RFB until the date the successful bidder accepts the Notice Of Award), contractors contemplating or preparing bids are prohibited from contacting CRRA staff or CRRA Board of Director members in an ex parte manner to discuss the RFB submission process. A contractor’s RFB submission shall be rejected if any of the foregoing ex parte communications take place.

5. Scope Of Work

CRRA is seeking bids from qualified contractors to furnish all tools, materials, labor, equipment and incidentals thereto for refurbishing belt conveyors CV-123/223 at the WPF (the “Work”). CRRA has divided the Work into two parts:

- (a) Providing the “parts” for refurbishment of the conveyors (the “Providing Parts Work”); and
- (b) Installing of the parts for refurbishment of the conveyors (the “Installation Work”).

Qualified contractors may bid on the Providing Parts Work or on the Installation Work or on both the Providing Parts Work and the Installation Work. The work to be performed for the two parts of the Work under this contract includes, but is not limited to the following items:

(a) Providing Parts Work:

- Provision of the following new conveyors CV-123/223 parts: new feed, return, push down and impact rails, for the full length on both sides of the conveyor; and
- Delivery of such parts to the WPF.

(b) Installation Work:

- Removal of existing conveyors CV-123/223;
- Installation of the following new conveyors CV-123/223 parts: new feed, return, push down and impact rails, for the full length on both sides of the conveyor;
- Installation of new tail and head assemblies that consist of conveyor chain sprockets, bearings, driven and floating sprockets along with new head and tail shafts;
- Installation of all new steel conveyor pans, conveyor chain, and conveyor wheels (Blocks), belonging to conveyors CV-123/223; and
- Installation activities will take place around the clock over a weekend.

Specific instructions about how the above Work is to be performed are included in **Exhibit A** (Project Specifications) of the Agreement. The Work is more particularly shown on certain drawings entitled “Drawings,” which drawings are set forth in **Exhibit B** of the Agreement.

6. Availability of RFB Package Documents

Complete sets of the RFB Package Documents may be obtained on the World Wide Web beginning Monday, November 24, 2008 at:

<http://www.crra.org> under the “Business Opportunities” page; select the “RFB: Re-furbishment Of Belt Conveyors CV-123/223 At The Mid-Connecticut Waste Processing Facility” link.

The RFB Package Documents are in PDF format. All of the forms included in the documents are also available for downloading in Microsoft Word format at the same place on CRRA’s web site where the PDF of the RFB is located. Prospective bidders can fill the forms out by typing the answers on their computer’s keyboard. The forms can then be printed and submitted with the bid. CRRA encourages firms to make use of the downloaded Word forms.

The RFB Package Documents are also available Monday through Friday, from 8:30 a.m. to 5:00 p.m. at CRRA’s offices, 100 Constitution Plaza, 6th Floor, Hartford, Connecticut 06103-1722, beginning on the same date. Anyone intending to pick up the documents at CRRA’s offices must contact Ms. Diane Goins [(860) 757-7700] at least 24 hours in advance.

7. Mandatory Pre-Bid Conference And Site Tour

A mandatory pre-bid conference and tour of the Site for all prospective bidders will be conducted by CRRA staff at 10:00 a.m. Eastern Time on Wednesday, December 3, 2008. Bids submitted by a bidder who did not attend the mandatory pre-bid conference and site tour shall be rejected. Alternate times for visiting the Site will not be allowed.

Prospective bidders should contact Mr. Richard Kowalski, Operations Engineer, at (860) 559-9478 or rkowalski@crra.org at least 24 hours prior to the mandatory pre-bid conference and site tour to make arrangements for participating in the tour and for directions to the Site. Except as otherwise authorized by this Instructions To Bidders, bidders are expressly prohibited from contacting any CRRA personnel regarding this bid solicitation.

8. Addenda And Interpretations

CRRA may issue Addenda to this bid package that shall, upon issuance, become part of this package and binding upon all potential or actual bidders for the Work. Such Addenda may be issued in response to requests for interpretation or clarification received from potential bidders. Any request for interpretation or clarification of any documents included in this bid package must be **submitted in writing to Ronald Gingerich by e-mail (rgingerich@crra.org), by fax ((860) 757-7742), or by correspondence (CRRA, 100 Constitution Plaza, 6th Floor, Hartford, Connecticut 06103-1722). To be given consideration, any such written request must be received by CRRA by 3:00 p.m., Monday, December 8, 2008.**

Addenda, if any, issued prior to the mandatory pre-bid conference and site tour will be mailed and/or e-mailed to all persons who picked up or requested a printed copy from CRRA of the bid package documents or who otherwise notified CRRA of their interest in the RFB. Such addenda will also be posted on CRRA’s web site (<http://www.crra.org> on

the "Business Opportunities" page under the "RFB: Refurbishment Of Belt Conveyors CV-123/223 At The Mid-Connecticut Waste Processing Facility" heading).

Addenda issued after the mandatory pre-bid conference and site tour will be mailed and/or e-mailed to all persons who attended the pre-bid conference and site tour and will be posted on CRRA's web site (<http://www.crra.org> on the "Business Opportunities" page under the "RFB: Refurbishment Of Belt Conveyors CV-123/223 At The Mid-Connecticut Waste Processing Facility" heading). Such addenda will be mailed/e-mailed and posted on the web site no later than three (3) days before the submittal deadline.

Failure of any bidder to receive any such Addenda shall not relieve such bidder from any conditions stipulated in such Addenda. Only questions answered or issues addressed by formal written Addenda will be binding. **All oral and other written responses, statements, interpretations or clarifications shall be without legal effect and shall not be binding upon CRRA.**

9. Bid Submittal Procedures

Sealed bids shall be submitted no later than 3:00 p.m., Eastern Time, Monday, December 22, 2008 at the offices of CRRA, 100 Constitution Plaza, 6th Floor, Hartford, Connecticut 06103-1722, Attn: Ronald Gingerich. Bids received after the time and date set forth above shall be rejected.

Each bidder must submit one (1) original and three (3) copies of its bid. The original bid shall be stamped or otherwise marked as such.

Each bid (the original and three copies) shall be enclosed in a sealed envelope that shall be clearly marked "Bid For Refurbishment Of Belt Conveyors CV-123/223 At The Mid-Connecticut Waste Processing Facility."

Bids shall remain open and subject to acceptance for ninety (90) days after the bid due date.

The terms and conditions of the Agreement (Section 15 of the RFB Package Documents), as attached, are non-negotiable. Any potential bidder that will be unable to execute the Agreement, as attached, should not submit a bid. The Agreement, as attached, is designed for the various alternatives that might result from the RFB process (i.e., for one bidder to be selected for both the Providing Parts Work and Installation Work or for two different bidders to be selected, one for the Providing Parts Work and the other for the Installation Work). CRRA will make whatever adjustments are necessary in the Agreement, as attached, to accurately reflect the alternative that results from the RFB process.

Bids may be modified or withdrawn by an appropriate document duly executed (in the manner that a bid must be executed) and delivered to the place where bids are to be submitted at any time prior to the bid due date.

10. Bid Security

Each bid shall be accompanied by a Bid Security. Any bid that does not contain a Bid Security or any bid that contains a Bid Security that does not comply with the following requirements shall be rejected as non-responsive.

10.1 Amount of Security

The Bid Security shall be in an amount equal to five percent (5%) of the amount of the bid.

10.2 Type of Security

The following are the acceptable forms of Bid Security:

- (a) A cashier's check;
- (b) A certified check; or
- (c) A bid bond in the form included in Section 3 of the RFB.

The Bid Security shall be made payable to CRRA.

Any bid bond submitted as Bid Security shall be in the form provided for such bid bond in Section 3 of the RFB and such bid bond shall be executed and issued by a surety company acceptable to CRRA.

10.3 Disposition of Bid Security

The Bid Security of the successful bidder will be retained until such bidder has executed the Agreement, furnished the required contract security and satisfied all other conditions of the Notice of Award, including execution and submission of the Contractor Certification Concerning Gifts, whereupon such Bid Security will be returned.

If the successful bidder fails to execute and deliver the Agreement, furnish the required contract security, or satisfy all other conditions of the Notice Of Award within ten (10) days after the issuance of such Notice Of Award, CRRA may annul the Notice Of Award and the Bid Security of that bidder shall be forfeited.

The Bid Security of other bidders whom CRRA believes to have a reasonable chance of receiving the award may be retained by CRRA until the earlier of the seventh (7th) day after the Effective Date of the Agreement or ninety (90) days after the bid due date, whereupon the Bid Security furnished by such bidders will be returned. Bid Security with bids that are not competitive will be returned within seven (7) days after the opening of such bids.

11. Bid Contents

Bids shall be submitted on forms provided by CRRA as part of this bid package, all of which forms must be completed with the appropriate information required and all blanks on such forms filled in.

A bid must consist of the following and must be in the following order:

- (a) Title page, including the title of the project, the name of the bidder and the date the bid is submitted;
- (b) Cover letter, signed by a person authorized to commit the bidder to the contractual arrangements with CRRA, which includes the following:
 - (1) The name of the bidder;
 - (2) The legal structure of the bidder (e.g., corporation, joint venture, etc.); and
 - (3) A clear statement indicating that the attached bid constitutes a firm and binding offer by the bidder to CRRA considering the terms and conditions outlined in the RFB and noting any technical exceptions taken thereto;
- (c) Table of Contents;
- (d) Bid Security (cashier's check, certified check or bid bond) (see Section 10 of this Instructions To Bidders);
- (e) The Bid Form (Section 4 of the RFB Package Documents), with Addenda, if any, listed in the appropriate place (Page 3), the name and address of the contact for Notices listed in the appropriate place (Page 7) and the completed agreement section (Page 8);
- (f) The completed Bid Price Form (Section 5 of the RFB Package Documents);
- (g) The completed References Form (Section 6 of the RFB Package Documents);
- (h) The completed Background And Experience Form (Section 7 of the RFB Package Documents);
- (i) The completed Subcontractor Identification Form (Section 8 of the RFB Package Documents);
- (j) The completed Questionnaire Concerning Affirmative Action, Small Business Contractors And Occupational Health And Safety (Section 9 of the RFB Package Documents);

- (k) The completed Certification Concerning Nondiscrimination (Section 10 of the RFB Package Documents), with the bidder's nondiscrimination policies and procedures attached;
- (l) The completed Background Questionnaire (Section 11 of the RFB Package Documents);
- (m) Copies of the Connecticut Department of Consumer Protection license numbers R7 and R8 that are currently held by employees of the bidder who would be assigned to work on the Project (see Section 17 of this Instructions To Bidders); and
- (n) A copy of the bidder's up-to-date certificate of insurance showing all current insurance coverage.

Bidders should not include in their bids other portions of the RFB Package Documents (e.g., this Instructions To Bidders or the Agreement).

A bidder may include additional information as an addendum/appendix to its bid if the bidder thinks that it will assist CRRA in evaluating the bidder's bid. A bidder should not include information that is not directly related to the subject matter of this solicitation.

12. Bid Opening

All bids will be opened at CRRA's convenience on or after the bid due date.

CRRA reserves the right to reject any or all of the bids, or any part(s) thereof, and/or to waive any informality or informalities in any bid or the RFB process for this Project.

13. Bid Evaluation

The award of the contract for the Work will be made, if at all, to the bidder(s) whose evaluation by CRRA results in CRRA determining that such award to such bidder(s) is in the best interests of CRRA. **However, the selection of a bidder(s) and the award of such contract, while anticipated, are not guaranteed.**

CRRA is an Equal Opportunity and Affirmative Action employer and does not discriminate in its hiring, employment, contracting, or business practices. CRRA is committed to complying with the Americans with Disability Act of 1990 (ADA) and does not discriminate on the basis of disability in admission to, access to, or operation of its programs, services, or activities.

CRRA will base its evaluation of the bids on price, qualifications, demonstrated skill, ability and integrity of each bidder to perform the Work required by the Contract Documents and any other factor or criterion that CRRA, in its sole discretion, deems or may deem relevant or pertinent for such evaluation.

14. Contract Award

If the contract is to be awarded, CRRA will issue to the successful bidder(s) a Notice Of Award within ninety (90) days after the bid due date.

CRRA reserves the right to correct inaccurate awards resulting from CRRA's errors. This may include, in extreme circumstances, revoking a Notice Of Award already made to a bidder and subsequently awarding the Notice of Award to another bidder. Such action by CRRA shall not constitute a breach of this RFB by CRRA since the Notice Of Award to the initial bidder is deemed to be void ab initio and of no effect as if no Agreement ever existed between CRRA and the initial bidder.

15. Contractor's Certification Concerning Gifts

Pursuant to *Connecticut General Statutes* Section 4-252, the apparently successful bidder(s) must submit a document certifying that it has not given any gifts to certain individuals between the date CRRA started planning the RFB and the date the Agreement is executed. If the apparently successful Bidder does not execute the Certification, it will be disqualified for the Agreement. The dates between which the bidder may not give gifts and the identities of those to whom it may not give gifts are specified in the attachment to the Notice Of Award included in the RFB Package Documents (see Attachment A to Section 13 of the RFB Package Documents).

16. Prevailing Wage Requirements

The Work, regardless of which part or parts of the Work for which the successful bidder(s) is selected, will be subject to the Prevailing Wage provisions of the *Connecticut General Statutes*. (See Section 8.7 of the Agreement.) In particular, within 30 days of receiving the contract award, the successful Bidder must furnish proof to the Connecticut Labor Commissioner that all of its employees and apprentices performing manual labor on the Project will have completed at 10-hour Occupational Safety and Health Administration ("OSHA") construction safety and health course.

17. Department Of Consumer Protection Licensing Requirements

Individuals working on conveyors are required to have obtained from the Connecticut Department of Consumer Protection one of the following licenses:

- (a) DCP License No. R7 – Elevator Limited Conveyor Contractor; or
- (b) DCP License No. R8 – Elevator Limited Conveyor Journeyman.

18. Bidder's Qualifications

CRRA may make any investigation deemed necessary to determine the ability of any bidder to perform the Work required. Each bidder shall furnish CRRA with all such information as may be required for this purpose.

19. Bid Preparation And Other Costs

Each bidder shall be solely responsible for all costs and expenses associated with the preparation and/or submission of its bid, or incurred in connection with any interviews and negotiations with CRRA, and CRRA shall have no responsibility or liability whatsoever for any such costs and expenses.

**REQUEST FOR BIDS
FOR
REFURBISHMENT OF BELT CONVEYORS CV-123/223
AT THE
MID-CONNECTICUT WASTE PROCESSING FACILITY**

**SECTION 3
BID BOND FORM**

BID/PROPOSAL BOND FORM

Any singular reference to Contractor, Surety, Owner or other party shall be considered plural where applicable. The below addresses are to be used for giving required notice.

BIDDER/PROPOSER (Name and Address):

SURETY (Name and Address of Principal Place of Business):

--	--

OWNER (Name and Address):

Connecticut Resources Recovery Authority 100 Constitution Plaza, 6 th Floor Hartford, CT 06103-1722
--

BID/PROPOSAL

DUE DATE:	
AMOUNT:	
PROJECT DESCRIPTION <small>(Including Name and Location):</small>	Refurbishment Of Belt Conveyors CV-123/223 at the Mid-Connecticut Waste Processing Facility Mid-Connecticut Waste Processing Facility 300 Maxim Road, Gate 70 Hartford, Connecticut 06114

BOND

BOND NUMBER:	
DATE <small>(Not later than Bid/Proposal Due Date):</small>	
PENAL SUM:	DOLLARS (\$ _____)

IN WITNESS WHEREOF, Surety and Bidder/Proposer, intending to be legally bound hereby, subject to the terms printed on Page 2 hereof, do each cause this Bid/Proposal Bond to be duly executed on its behalf by its authorized officer, agent, or representative.

BIDDER/PROPOSER

SURETY

--

(SEAL)

--

(SEAL)

Bidder's Name and Corporate Seal

Surety's Name and Corporate Seal

SIGNATURE:		SIGNATURE:	
NAME AND TITLE:		NAME AND TITLE:	

TERMS AND CONDITIONS TO BID/PROPOSAL BOND

1. Bidder/Proposer and Surety, jointly and severally, bind themselves, their heirs, executors, administrators, successors and assigns to pay to Owner upon default of Bidder/Proposer any difference between the total amount of Bidder's/Proposer's bid/proposal and the total amount of the bid/proposal of the next lowest, responsible and responsive bidder/proposer as determined by Owner for the Work/Service required by the Contract Documents, provided that:
 - 1.1 If there is no such next lowest, responsible and responsive bidder/proposer, and Owner does not abandon the Project, then Bidder/Proposer and Surety shall pay to Owner the penal sum set forth on the face of this Bond, and
 - 1.2 In no event shall Bidder's/Proposer's and Surety's obligation hereunder exceed the penal sum set forth on the face of this Bond.
2. Default of Bidder/Proposer shall occur upon the failure of Bidder/Proposer to deliver within the time required by the Bid/Proposal Documents (or any extension thereof agreed to in writing by Owner) the executed Agreement and related documents required by the Bid/Proposal Documents and any performance and payment bonds required by the Bid/Proposal Documents and Contract Documents.
3. This obligation shall be null and void if:
 - 3.1 Owner accepts Bidder's/Proposer's bid/proposal and bidder/proposer delivers within the time required by the Bid/Proposal Documents (or any extension thereof agreed to in writing by Owner) the executed Agreement and related documents required by the Bid/Proposal Documents and any performance and payments bonds required by the Bid/Proposal Documents and Contract Documents, or
 - 3.2 All bids/proposals are rejected by Owner, or
 - 3.3 Owner fails to issue a notice of award to Bidder/Proposer within the time specified in the Bid/Proposal Documents (or any extension thereof agreed to in writing by Bidder/Proposer and, if applicable, consented to by Surety when required by paragraph 5 hereof).
4. Payment under this Bond will be due and payable upon default by Bidder/Proposer and within 30 calendar days after receipt by Bidder/Proposer and Surety of written notice of default from Owner, which notice will be given with reasonable promptness, identifying this Bond and the Project and including a statement of the amount due.
5. Surety waives notice of any and all defenses based on or arising out of any time extension to issue notice of award agreed to in writing by Owner and Bidder/Proposer, provided that the total time for issuing notice of award including extensions shall not in the aggregate exceed 120 days from Bid/Proposal Due Date without Surety's written consent.
6. No suit or action shall be commenced under this Bond prior to 30 calendar days after the notice of default required in paragraph 4 above is received by Bidder/Proposer and Surety and in no case later than one year after Bid/Proposal Due Date.
7. Any suit or action under this Bond shall be commenced only in a court of competent jurisdiction located in the state in which the Project is located.
8. Notices required hereunder shall be in writing and sent to Bidder/Proposer and Surety at their respective addresses shown on the face of this Bond. Such notices may be sent by personal delivery, commercial courier or by United States Registered or Certified Mail, return receipt requested, postage pre-paid, and shall be deemed to be effective upon receipt by the party concerned.
9. Surety shall cause to be attached to this Bond a current and effective Power of Attorney evidencing the authority of the officer, agent or representative who executed this Bond on behalf of Surety to execute, seal and deliver such Bond and bind the Surety thereby.
10. This Bond is intended to conform to all applicable statutory requirements. Any applicable requirement of any applicable statute that has been omitted from this Bond shall be deemed to be included herein as if set forth at length. If any provision of this Bond conflicts with any applicable provision of any applicable statute, then the provision of said statute shall govern and the remainder of this Bond that is not in conflict therewith shall continue in full force and effect.

**REQUEST FOR BIDS
FOR
REFURBISHMENT OF BELT CONVEYORS CV-123/223
AT THE
MID-CONNECTICUT WASTE PROCESSING FACILITY**

**SECTION 4
BID FORM**



BID FORM

PROJECT: Mid-Connecticut
RFB NUMBER: FY09-OP-009
CONTRACT FOR: Refurbishment Of Belt Conveyors CV-123/223 At The Mid-Connecticut Waste Processing Facility
BID SUBMITTED TO: Connecticut Resources Recovery Authority
100 Constitution Plaza, 6th Floor
Hartford, Connecticut 06103-1722

1. WORK FOR WHICH BID IS SUBMITTED

In the table below, place a check mark in the box for the portion of the Work for which the bidder wishes to be considered.

<input type="checkbox"/>	Providing Parts Work for the refurbishment of belt conveyors CV-123/223 at the Waste Processing Facility
<input type="checkbox"/>	Installation Work for the refurbishment of belt conveyors CV-123/223 at the Waste Processing Facility
<input type="checkbox"/>	Both Providing Parts Work and Installation Work for the refurbishment of belt conveyor CV-123/223 at the Waste Processing Facility

2. DEFINITIONS

Unless otherwise defined herein, all terms that are not defined and used in this Bid Form (a "Bid") shall have the same respective meanings assigned to such terms in the Contract Documents.

3. TERMS AND CONDITIONS

The undersigned (the "Bidder") accepts and agrees to all terms and conditions of the Request For Bids, Instructions To Bidders, the Agreement and any Addenda to any such documents. This Bid shall remain open and subject to acceptance for ninety (90) days after the bid due date.

If CRRA issues a Notice Of Award to Bidder, Bidder shall within ten (10) days after the date thereof:

- (a) Execute and deliver to CRRA the required number of counterparts of the non-negotiable Agreement;
- (b) Execute and deliver to CRRA the Contractor's Certification Concerning Gifts;
- (c) Execute and deliver to CRRA all other Contract Documents attached to the Notice Of Award along with any other documents required by the Contract Documents; and
- (d) Satisfy all other conditions of the Notice Of Award.

4. BIDDER'S OBLIGATIONS

Bidder proposes and agrees, if this Bid is accepted by CRRA and CRRA issues a Notice Of Award to Bidder, to the following:

- (a) To perform, furnish and complete all the Work as specified or indicated in the Contract Documents and Agreement for the Bid Price and within the Contract Time set forth in this Bid and in accordance with the terms and conditions of the Contract Documents and Agreement; and
- (b) At the request of CRRA and if the successful Bidder qualifies, to apply with the State of Connecticut Department Administrative Services, and do all that is necessary to make itself qualify, as a Small Contractor and/or Minority/Women/Disabled Person Business Enterprise in accordance with Section 4a-60g of the *Connecticut General Statutes*.

5. BIDDER'S REPRESENTATIONS CONCERNING NON-NEGOTIABILITY OF THE AGREEMENT

In submitting this Bid, Bidder acknowledges and agrees that the terms and conditions of the Agreement (including all Exhibits thereto), as included in the RFB Package Documents, are non-negotiable, and Bidder is willing to and shall, if CRRA accepts its Bid for the Work and issues a Notice Of Award to Bidder, execute such Agreement. However, CRRA reserves the right to negotiate with Bidder over Bidder's price for the Work submitted on its Bid Price Form.

6. BIDDER'S REPRESENTATIONS CONCERNING EXAMINATION OF CONTRACT DOCUMENTS

In submitting this Bid, Bidder represents that:

- (a) Bidder has thoroughly examined and carefully studied the RFB Package Documents and the following Addenda, receipt of which is hereby acknowledged (list Addenda by Addendum number and date):

Addendum Number	Date Issued

- (b) Without exception the Bid is premised upon performing, furnishing and completing the Work required by the Contract Documents and applying the specific means, methods, techniques, sequences or procedures (if any) that may be shown, indicated or expressly required by the Contract Documents;
- (c) Bidder is fully informed and is satisfied as to all Laws And Regulations that may affect cost, progress, performance, furnishing and/or completion of the Work;
- (d) Bidder has studied and carefully correlated Bidder's knowledge and observations with the Contract Documents and such other related data;
- (e) Bidder has given CRRA written notice of all conflicts, errors, ambiguities and discrepancies that Bidder has discovered in the Contract Documents and the written resolutions thereof by CRRA are acceptable to Bidder;
- (f) If Bidder has failed to promptly notify CRRA of all conflicts, errors, ambiguities and discrepancies that Bidder has discovered in the Contract Documents, such failure shall be deemed by both Bidder and CRRA to be a waiver to assert these issues and claims in the future;
- (g) Bidder is aware of the general nature of work to be performed by CRRA and others that relates to the Work for which this Bid is submitted; and
- (h) The Contract Documents are generally sufficient to indicate and convey understanding by Bidder of all terms and conditions for performing, furnishing and completing the Work for which this Bid is submitted.

7. BIDDER'S REPRESENTATIONS CONCERNING SITE CONDITIONS

In submitting this Bid, Bidder acknowledges and agrees that:

- (a) All information and data included in the RFB Package Documents relating to the surface, subsurface and other conditions of the Site are from presently available sources and are being provided only for the information and convenience of the bidders;

- (b) CRRA does not assume any responsibility for the accuracy or completeness of such information and data, if any, shown or indicated in the Contract Documents with respect to any surface, subsurface or other conditions of the Site(s);
- (c) Bidder is solely responsible for investigating and satisfying itself as to all actual and existing Site conditions, including surface conditions, subsurface conditions and underground facilities; and
- (d) Bidder has visited the Site and has become familiar with and is satisfied as to the general, local, and site conditions that may affect cost, progress, performance, furnishing and completion of the Work.

8. BIDDER'S REPRESENTATIONS CONCERNING INFORMATION MADE AVAILABLE

In submitting this Bid, Bidder acknowledges and agrees that Bidder shall not use any information made available to it or obtained in any examination made by it in connection with this RFB in any manner as a basis or grounds for a claim or demand of any nature against CRRA arising from or by reason of any variance which may exist between information offered or so obtained and the actual materials, conditions, or structures encountered during performance of any of the Work.

9. BIDDER'S REPRESENTATIONS CONCERNING STATE OF CONNECTICUT TAXES

In submitting this Bid, Bidder acknowledges and agrees that CRRA is exempt from all State of Connecticut taxes and assessments, including sales and use taxes. Accordingly, Bidder shall not charge CRRA any State of Connecticut taxes or assessments at any time in connection with Bidder's performance of this Agreement, nor shall Bidder include any State of Connecticut taxes or assessments in any rates, costs, prices or other charges to CRRA hereunder. Bidder represents and warrants that no State of Connecticut taxes or assessments were included in any rates, costs, prices or other charges presented to CRRA in any bid or other submittal to CRRA in connection with this RFB.

10. BIDDER'S REPRESENTATIONS CONCERNING DISCLOSURE OF INFORMATION

In submitting this Bid, Bidder:

- (a) Recognizes and agrees that CRRA is subject to the Freedom of Information provisions of the *Connecticut General Statutes* and, as such, any information contained in or submitted with or in connection with Bidder's Bid is subject to disclosure if required by law or otherwise; and
- (b) Expressly waives any claim(s) that Bidder or any of its successors and/or assigns has or may have against CRRA or any of its directors, officers, employees or authorized agents as a result of any such disclosure.

11. BIDDER'S REPRESENTATIONS CONCERNING NON-COLLUSION

By submission of this Bid, the Bidder, together with any affiliates or related persons, the guarantor, if any, and any joint ventures, hereby represents that, under risk of termination of the Agreement, if awarded, to the best of its knowledge and belief:

- (a) The prices in the Bid have been arrived at as the result of an independent business judgment without collusion, consultation, communication, agreement or otherwise for the purpose of restricting competition, as to any matter relating to such prices and any other person or company;
- (b) Unless otherwise required by law, the prices that have been quoted in this Bid have not, directly or indirectly, been knowingly disclosed by the Bidder prior to "opening" to any other person or company;
- (c) No attempt has been made or will be made by the Bidder to induce any other person, partnership or corporation to submit, or not to submit, a bid for the purpose of restricting competition;
- (d) Bidder has not directly or indirectly induced or solicited any other bidder to submit a false or sham bid; and
- (e) Bidder has not sought by collusion to obtain for itself any advantage for the Work over any other bidder for the Work or over CRRA.

12. BIDDER'S REPRESENTATIONS CONCERNING RFB FORMS

By submission of this Bid, the Bidder, together with any affiliates or related business entities or persons, the guarantor, if any, and any joint ventures, hereby represents that, under risk of termination of the Agreement, if awarded, all of the forms included in the RFB that are submitted to CRRA as part of its Bid are identical in form and content to the preprinted forms in the RFB Package Documents except that information requested by the forms has been inserted in the spaces on the forms provided for the insertion of such requested information.

13. BID SECURITY

Bidder acknowledges and agrees that the amount of the Bid Security submitted with this Bid fairly and reasonably represents the amount of damages CRRA will suffer in the event that Bidder fails to fulfill any of its obligations set forth in the Contract Documents.

14. BIDDER'S WAIVER OF DAMAGES

Bidder and all its affiliates and subsidiaries understand that by submitting a Bid, Bidder is acting at its and their own risk and Bidder does for itself and all its affiliates, subsidiaries, successors and assigns hereby waive any rights any of them may have to receive any damages for any liability, claim, loss or injury resulting from:

- (a) Any action or inaction on the part of CRRA or any of its directors, officers, employees or authorized agents concerning the evaluation, selection, non-selection and/or rejection of any or all bids by CRRA or any of its directors, officers, employees or authorized agents;
- (b) Any agreement entered into for the Work (or any part thereof) described in the Contract Documents; and/or
- (c) Any award or non-award of a contract for the Work (or any part thereof) pursuant to the Contract Documents.

15. BIDDER'S REPRESENTATION REGARDING THE CONNECTICUT CAMPAIGN CONTRIBUTION AND SOLICITATION BAN

With regard to a State contract as defined in P.A. 07-1 having a value in a calendar year of \$50,000 or more or a combination or series of such agreement or contracts having a value of \$100,000 or more, the authorized signatory to this submission in response to CRRA's solicitation expressly acknowledges receipt of the State Elections Enforcement Commission's notice advising prospective state contractors of state campaign contribution and solicitation prohibitions, and will inform its principals of the contents of the notice. See Section 12 [SEEC Form 11] of the Contract Documents.

16. ATTACHMENTS

The following documents are attached hereto and made a part of this Bid:

- (a) Bid Security;
- (b) The completed Bid Price Form;
- (c) The completed References Form;
- (d) The completed Background And Experience Form;
- (e) The completed Subcontractor Identification Form;
- (f) Questionnaire Concerning Affirmative Action, Small Business Contractors And Occupational Health And Safety that has been completely filled out by the Bidder;
- (g) Certification Concerning Nondiscrimination that has been completely filled out and signed by Bidder, with the Bidder's nondiscrimination policies and procedures attached;
- (h) Background Questionnaire that has been completely filled out by the Bidder and signed before a Notary Public or Commissioner of the Superior Court;

- (i) Copies of the Connecticut Department of Consumer Protection license numbers R7 and R8 that are currently held by employees of the bidder who would be assigned to work on the Project; and
- (j) A copy of the Bidder's up-to-date certificate of insurance showing all current insurance coverage.

17. NOTICES

Communications concerning this Bid should be addressed to Bidder at the address set forth below.

Bidder Name:	
Bidder Contact:	
Title:	
Address:	
Telephone Number:	
Fax Number:	
E-Mail Address:	

18. ADDITIONAL REPRESENTATION

Bidder hereby represents that the undersigned is duly authorized to submit this Bid on behalf of Bidder.

AGREED TO AND SUBMITTED ON _____, 2008

Name of Bidder (Firm):	
Signature of Bidder Representative:	
Name (Typed/Printed):	
Title (Typed/Printed):	

**REQUEST FOR BIDS
FOR
REFURBISHMENT OF BELT CONVEYORS CV-123/223
AT THE
MID-CONNECTICUT WASTE PROCESSING FACILITY**

**SECTION 5
BID PRICE FORM**



BID PRICE FORM

**Refurbishment Of Belt Conveyors CV-123/223
At The
Mid-Connecticut Waste Processing Facility
(RFB Number 09-OP-009)**

Bidder will complete the Work as specified in the Contract Documents for the Refurbishment of Belt Conveyors CV-123/223 for the following lump sum bid price (please use tables below). Bidder may bid on Item 1.1, "Providing Parts Work," or Item 1.2, "Installation Work," or both Items 1.1 and 1.2.

1. Providing Parts Work

	Dollars	Cents
TOTAL PROVIDING PARTS WORK BID PRICE		
	(Use Numbers)	

TOTAL PROVIDING PARTS WORK BID PRICE	
	(Use Words)

2. Installation Work

	Dollars	Cents
TOTAL INSTALLATION WORK BID PRICE		
	(Use Numbers)	

TOTAL INSTALLATION WORK BID PRICE	
	(Use Words)

Bidder affirms that the total bid price above represents the entire cost to complete the Work in accordance with the Contract Documents, and that no claim will be made on account of any increase in wage scales, material prices, delivery delays, taxes, insurance, cost indexes or any other rates affecting the construction industry or this Project, and that each and every such claim is hereby expressly waived by Bidder.

Name of Bidder (Firm):	
Signature of Bidder Representative:	
Name (Type/Print):	
Title:	
Date:	

**REQUEST FOR BIDS
FOR
REFURBISHMENT OF BELT CONVEYORS CV-123/223
AT THE
MID-CONNECTICUT WASTE PROCESSING FACILITY**

**SECTION 6
REFERENCES FORM**



REFERENCES FORM

In space below, provide the names of three (3) references who can attest to the quality of work performed/services provided by Bidder/Proposer. Include job title, affiliation, address, phone number and a brief description of the work performed/services provided for each reference.

REFERENCE 1

Name of Person:	
Title:	
Name of Firm:	
Address:	
Telephone Number:	
Description Of Work Performed:	

REFERENCE 2

Name of Person:	
Title:	
Name of Firm:	
Address:	
Telephone Number:	
Description Of Work Performed:	

REFERENCE 3

Name of Person:	
Title:	
Name of Firm:	
Address:	
Telephone Number:	
Description Of Work Performed:	

**REQUEST FOR BIDS
FOR
REFURBISHMENT OF BELT CONVEYORS CV-123/223
AT THE
MID-CONNECTICUT WASTE PROCESSING FACILITY**

SECTION 7

BACKGROUND AND EXPERIENCE FORM

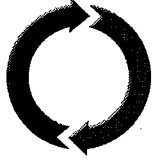

CONNECTICUT
RESOURCES
RECOVERY
AUTHORITY

BACKGROUND AND EXPERIENCE FORM

In the space below, summarize work performed/services provided of a similar nature to that specified in the Contract Documents which has been performed by the bidder/proposer and which will enable CRRA to evaluate the experience and professional capabilities of the bidder/proposer.

[Attach Additional Pages If Necessary]

**REQUEST FOR BIDS
FOR
REFURBISHMENT OF BELT CONVEYORS CV-123/223
AT THE
MID-CONNECTICUT WASTE PROCESSING FACILITY**

**SECTION 8
SUBCONTRACTOR IDENTIFICATION FORM**



SUBCONTRACTOR IDENTIFICATION FORM
--

Bidder shall list below all subcontractor(s) Bidder intends to use in the performance of Services if Bidder is selected to perform the Services and awarded the Agreement. Bidder shall include a description of the Services to be provided by the subcontractor(s).

Subcontractor 1

Company Name	
Services To Be Provided	

Subcontractor 2

Company Name	
Services To Be Provided	

Subcontractor 3

Company Name	
Services To Be Provided	

Subcontractor 4

Company Name	
Services To Be Provided	

**REQUEST FOR BIDS
FOR
REFURBISHMENT OF BELT CONVEYORS CV-123/223
AT THE
MID-CONNECTICUT WASTE PROCESSING FACILITY**

**SECTION 9
QUESTIONNAIRE CONCERNING AFFIRMATIVE
ACTION, SMALL BUSINESS CONTRACTORS
AND OCCUPATIONAL HEALTH AND SAFETY**



QUESTIONNAIRE CONCERNING AFFIRMATIVE ACTION, SMALL BUSINESS CONTRACTORS AND OCCUPATIONAL HEALTH AND SAFETY

Because CRRA is a political subdivision of the State of Connecticut, it is required by various statutes and regulations to obtain background information on prospective contractors prior to entering into a contract. The questions below are designed to assist CRRA in procuring this information. Many of the questions are required to be asked by RCSA 46a-68j-31. For the purposes of this form, "Contractor" means Bidder or Proposer, as appropriate.

	Yes	No
1. Is the Contractor an Individual? <i>If you answered "Yes" to Question 1, skip to Question 2.</i> <i>If you answered "No" to Question 1, proceed to Question 1A and then to Question 2.</i>	<input type="checkbox"/>	<input type="checkbox"/>
1A. How many employees does the Contractor have? <input type="text"/>		
2. Is the Contractor a Small Contractor based on the criteria in Schedule A? <i>If you answered "Yes" to Question 2, proceed to Question 2A and then to Question 3.</i> <i>If you answered "No" to Question 2, skip to Question 3.</i>	<input type="checkbox"/>	<input type="checkbox"/>
2A. Is the Contractor registered with the DAS as a Certified Small Business? <i>If you answered "Yes" to Question 2A, please provide a copy of your Set-Aside Certificate.</i>	<input type="checkbox"/>	<input type="checkbox"/>
3. Is the Contractor a MWDP Business Enterprise based on the criteria in Schedule B? <i>If you answered "Yes" to Question 3, proceed to Question 3A and then to Question 4.</i> <i>If you answered "No" to Question 3, skip to Question 4.</i>	<input type="checkbox"/>	<input type="checkbox"/>
3A. Is the Contractor registered with DAS as a MWDP Small Business?	<input type="checkbox"/>	<input type="checkbox"/>
4. Does the Contractor have an Affirmative Action Plan? <i>If you answered "Yes" to Question 4, proceed to Question 4A and then to Question 5.</i> <i>If you answered "No" to Question 4, skip to Question 4B and then to Question 5.</i>	<input type="checkbox"/>	<input type="checkbox"/>
4A. Has the Affirmative Action Plan been approved by the CHRO?	<input type="checkbox"/>	<input type="checkbox"/>
4B. Will the Contractor develop and implement an Affirmative Action Plan?	<input type="checkbox"/>	<input type="checkbox"/>
5. Does the Contractor have an apprenticeship program complying with RCSA 46a-68-1 through 46a-68-17?	<input type="checkbox"/>	<input type="checkbox"/>
6. Has the Contractor been cited for three or more willful or serious violations of any occupational safety and health act?	<input type="checkbox"/>	<input type="checkbox"/>
7. Has the Contractor received one or more criminal convictions related to the injury or death of any employee in the three-year period preceding the issuance of this Request For Bids/Proposals/Qualifications?	<input type="checkbox"/>	<input type="checkbox"/>
8. Has the Contractor been the recipient of one or more ethical violations from the State of Connecticut Ethics Commission during the three-year period preceding the issuance of this Request For Bids/Proposals/Qualifications?	<input type="checkbox"/>	<input type="checkbox"/>
9. Will subcontractors be involved? <i>If you answered "Yes" to Question 9, proceed to Question 9A.</i> <i>If you answered "No" to Question 9, you are finished with the questionnaire.</i>	<input type="checkbox"/>	<input type="checkbox"/>
9A. How many subcontractors will be involved? <input type="text"/>		

LIST OF ACRONYMS

- RCSA – Regulations of Connecticut State Agencies
CHRO – State of Connecticut Commission on Human Rights and Opportunities
DAS – State of Connecticut Department of Administrative Services
MWDP – Minority/Women/Disabled Person

FOOTNOTE

- ¹ If the Contract is a "public works contract" (as defined in Section 46a-68b of the Connecticut General Statutes), the dollar amount exceeds \$50,000.00 in any fiscal year, and the Contractor has 50 or more employees, the Contractor, in accordance with the provisions of Section 46a-68c of the Connecticut General Statutes, shall develop and file an affirmative action plan with the Connecticut Commission on Human Rights and Opportunities.

SCHEDULE A CRITERIA FOR A SMALL CONTRACTOR

Contractor must meet all of the following criteria to qualify as a Small Contractor:

1. Has been doing business and has maintained its principal place of business in the State for a period of at least one year immediately preceding the issuance of the Request For Bids/Proposals/Qualifications;
2. Has had gross revenues not exceeding ten million dollars in the most recently completed fiscal year;
3. Is headquartered in Connecticut; and,
4. At least 51% of the ownership of the Contractor is held by a person or persons who are active in the daily affairs of the business and have the power to direct the management and policies of the business.

SCHEDULE B CRITERIA FOR A MINORITY/WOMAN/DISABLED PERSON BUSINESS ENTERPRISE

Contractor must meet all of the following criteria to qualify as a Minority/Woman/Disabled Person Business Enterprise:

1. Satisfies all of the criteria in Schedule A for a Small Contractor;
2. 51% or more of the business and/or its assets must be owned by a person or persons who are minorities as defined in Connecticut General Statutes Section 32-9n (please see below) or is an individual with a disability;
3. The Minority/Woman/Disabled Person must have the power to change policy and management of the business; and,
4. The Minority/Woman/Disabled Person must be active in the day-to-day affairs of the business.

CONNECTICUT GENERAL STATUTES SECTION 32-9n

Sec. 32-9n. Office of Small Business Affairs. (a) There is established within the Department of Economic and Community Development an Office of Small Business Affairs. Such office shall aid and encourage small business enterprises, particularly those owned and operated by minorities and other socially or economically disadvantaged individuals in Connecticut. As used in this section, minority means: (1) Black Americans, including all persons having origins in any of the Black African racial groups not of Hispanic origin; (2) Hispanic Americans, including all persons of Mexican, Puerto Rican, Cuban, Central or South American, or other Spanish culture or origin, regardless of race; (3) all persons having origins in the Iberian Peninsula, including Portugal, regardless of race; (4) women; (5) Asian Pacific Americans and Pacific islanders; or (6) American Indians and persons having origins in any of the original peoples of North America and maintaining identifiable tribal affiliations through membership and participation or community identification.

**REQUEST FOR BIDS
FOR
REFURBISHMENT OF BELT CONVEYORS CV-123/223
AT THE
MID-CONNECTICUT WASTE PROCESSING FACILITY**

**SECTION 10
CERTIFICATION CONCERNING
NONDISCRIMINATION**



**CERTIFICATION CONCERNING
NONDISCRIMINATION**

This certification must be executed by an individual or business entity submitting a bid/proposal/statement of qualifications to the Connecticut Resources Recovery Authority (such individual or business entity hereinafter referred to as the "Contractor") regarding support of nondiscrimination against persons on account of their race, color, religious creed, age, marital or civil union status, national origin, ancestry, sex, mental retardation, physical disability or sexual orientation.

I, _____, a duly authorized officer and/or representative
of _____ (firm name)
(the "Contractor"), hereby certify that:

1. Contractor seeks to enter into the Refurbishment Of Belt Conveyors CV-123/223 At The Mid-Connecticut Waste Processing Facility Agreement (the "Agreement") with the Connecticut Resources Recovery Authority; and
2. In carrying out its obligation under the Agreement, Contractor will abide by the nondiscrimination agreements and warranties required under Connecticut General Statutes Sections 4a-60(a)(1) and 4a-60a(a)(1), as amended in State of Connecticut Public Act 07-245 and Sections 9(a)(1) and 10(a)(1) of Public Act 07-142; and
3. Attached are the policies and procedures concerning nondiscrimination, which have not been modified or rescinded, adopted by the appropriate governing body or management of Contractor; and
4. The information set forth herein is true, complete and accurate to the best of my knowledge and belief.

IN WITNESS WHEREOF, the undersigned has executed this certificate this

_____ day of _____ 200 8

By (Signature): _____

Name (Print): _____

Title: _____

**REQUEST FOR BIDS
FOR
REFURBISHMENT OF BELT CONVEYORS CV-123/223
AT THE
MID-CONNECTICUT WASTE PROCESSING FACILITY**

SECTION 11

BACKGROUND QUESTIONNAIRE



BACKGROUND QUESTIONNAIRE

This Questionnaire must be completed and properly executed by an individual or business entity submitting a bid/proposal/statement of qualifications to the Connecticut Resources Recovery Authority (such individual or business entity hereinafter referred to as the "Contractor").

Please answer the following questions by placing an "X" in the appropriate box.

	Yes	No
<p>1. Has the Contractor or any of its principals, owners, officers, partners, directors or stockholders holding more than 50% of the stock of the Contractor ever been the subject of a criminal investigation?</p> <p><i>If you answered "Yes" to Question 1, proceed to Question 1A and, on a separate sheet of paper, state the following: the court in which the investigation is taking or took place; the approximate date the investigation commenced and, if applicable, concluded; the subject matter of the investigation; and the identity of the person or entity involved.</i></p> <p><i>If you answered "No" to Question 1, proceed to Question 2.</i></p>	<input type="checkbox"/>	<input type="checkbox"/>
<p>1A. Has any indictment arisen out of any such investigation?</p> <p><i>If you answered "Yes" to Question 1A, proceed to Question 2 and, on a separate sheet of paper, state the following: the name of the person or entity indicted; and the status of any such indictment.</i></p> <p><i>If you answered "No" to Question 1A, proceed to Question 2.</i></p>	<input type="checkbox"/>	<input type="checkbox"/>
<p>2. Has the Contractor or any of its principals, owners, officers, partners, directors or stockholders holding more than 50% of the stock of the Contractor ever been the subject of a civil investigation?</p> <p><i>If you answered "Yes" to Question 2, proceed to Question 3 and, on a separate sheet of paper, state the following: the court or other forum in which the investigation took or is taking place; the approximate date the investigation commenced and, if applicable, concluded; the subject matter of the investigation; the identity of the person or entity involved; and the status of the investigation.</i></p> <p><i>If you answered "No" to Question 2, proceed to Question 3.</i></p>	<input type="checkbox"/>	<input type="checkbox"/>
<p>3. Has any entity (e.g., corporation, partnership, etc.) in which a principal, owner, officer, partner, director or stockholder of the Contractor has an ownership interest in excess of 50% in such entity ever been the subject of a criminal investigation?</p> <p><i>If you answered "Yes" to Question 3, proceed to Question 3A and, on a separate sheet of paper, state the following: the court in which the investigation is taking or took place; the approximate date the investigation commenced and, if applicable, concluded; the subject matter of the investigation; and the identity of the person or entity involved.</i></p> <p><i>If you answered "No" to Question 3, proceed to Question 4.</i></p>	<input type="checkbox"/>	<input type="checkbox"/>
<p>3A. Has any indictment arisen out of any such investigation?</p> <p><i>If you answered "Yes" to Question 3A, proceed to Question 4 and, on a separate sheet of paper, state the following: the name of the person or entity indicted; and the status of any such indictment.</i></p> <p><i>If you answered "No" to question 3A, proceed to Question 4.</i></p>	<input type="checkbox"/>	<input type="checkbox"/>

	Yes	No
<p>4. Has any entity (e.g., corporation, partnership, etc.) in which a principal, owner, officer, partner, director or stockholder of the Contractor has an ownership interest in excess of 50% in such entity ever been the subject of a civil investigation?</p> <p><i>If you answered "Yes" to Question 4, on a separate sheet of paper state the following: the court in which the investigation is taking or took place; the approximate date the investigation commenced and, if applicable, concluded; the subject matter of the investigation; the identity of the person or entity involved; and the status of the investigation.</i></p>	<input type="checkbox"/>	<input type="checkbox"/>
<p>5. Has the Contractor or any of its principals, owners, officers, partners, directors or stockholders holding more than 50% of the stock of the Contractor ever been debarred from bidding on, or otherwise applying for, any contract with the State of Connecticut or any other governmental authority?</p> <p><i>If you answered "Yes" to Question 5, on a separate sheet of paper please explain.</i></p>	<input type="checkbox"/>	<input type="checkbox"/>

Signature: _____

Name (print/type): _____

Title: _____

State Of: _____

County Of: _____

_____, being fully sworn, deposes and says that he/she is the _____ (Title) of _____ (Firm Name), the Contractor herein, that he/she has provided answers to the foregoing questions on the Contractor's background, and, under the penalty of perjury, certifies that each and every answer is true.

Sworn to before me this _____ day of _____ 200 8

Notary Public/Commissioner of the Superior Court

**REQUEST FOR BIDS
FOR
REFURBISHMENT OF BELT CONVEYORS CV-123/223
AT THE
MID-CONNECTICUT WASTE PROCESSING FACILITY**

SECTION 12

**SEEC FORM 11
NOTICE TO EXECUTIVE BRANCH STATE
CONTRACTORS AND PROSPECTIVE STATE
CONTRACTORS OF CAMPAIGN CONTRIBUTION
AND SOLICITATION BAN**

SEEC FORM 11

NOTICE TO EXECUTIVE BRANCH STATE CONTRACTORS AND PROSPECTIVE STATE CONTRACTORS OF CAMPAIGN CONTRIBUTION AND SOLICITATION BAN

This notice is provided under the authority of Connecticut General Statutes 9-612(g)(2), as amended by P.A. 07-1, and is for the purpose of informing state contractors and prospective state contractors of the following law (italicized words are defined on the following page):

Campaign Contribution and Solicitation Ban

No *state contractor, prospective state contractor, principal of a state contractor or principal of a prospective state contractor*, with regard to a *state contract or state contract solicitation* with or from a state agency in the executive branch or a quasi-public agency or a holder, or principal of a holder of a valid prequalification certificate, shall make a contribution to, or *solicit* contributions on behalf of (i) an exploratory committee or candidate committee established by a candidate for nomination or election to the office of Governor, Lieutenant Governor, Attorney General, State Comptroller, Secretary of the State or State Treasurer, (ii) a political committee authorized to make contributions or expenditures to or for the benefit of such candidates, or (iii) a party committee;

In addition, no holder or principal of a holder of a valid prequalification certificate, shall make a contribution to, or solicit contributions on behalf of (i) an exploratory committee or candidate committee established by a candidate for nomination or election to the office of State senator or State representative, (ii) a political committee authorized to make contributions or expenditures to or for the benefit of such candidates, or (iii) a party committee.

Duty to Inform

State contractors and prospective state contractors are required to inform their principals of the above prohibitions, as applicable, and the possible penalties and other consequences of any violation thereof.

Penalties for Violations

Contributions or solicitations of contributions made in violation of the above prohibitions may result in the following civil and criminal penalties:

Civil penalties--\$2000 or twice the amount of the prohibited contribution, whichever is greater, against a principal or a contractor. Any state contractor or prospective state contractor which fails to make reasonable efforts to comply with the provisions requiring notice to its principals of these prohibitions and the possible consequences of their violations may also be subject to civil penalties of \$2000 or twice the amount of the prohibited contributions made by their principals.

Criminal penalties—Any knowing and willful violation of the prohibition is a Class D felony, which may subject the violator to imprisonment of not more than 5 years, or \$5000 in fines, or both.

Contract Consequences

Contributions made or solicited in violation of the above prohibitions may result, in the case of a state contractor, in the contract being voided.

Contributions made or solicited in violation of the above prohibitions, in the case of a prospective state contractor, shall result in the contract described in the state contract solicitation not being awarded to the prospective state contractor, unless the State Elections Enforcement Commission determines that mitigating circumstances exist concerning such violation.

The State will not award any other state contract to anyone found in violation of the above prohibitions for a period of one year after the election for which such contribution is made or solicited, unless the State Elections Enforcement Commission determines that mitigating circumstances exist concerning such violation.

Additional information and the entire text of P.A. 07-1 may be found on the website of the State Elections Enforcement Commission, www.ct.gov/seec. Click on the link to "State Contractor Contribution Ban."

Definitions:

"State contractor" means a person, business entity or nonprofit organization that enters into a state contract. Such person, business entity or nonprofit organization shall be deemed to be a state contractor until December thirty-first of the year in which such contract terminates. "State contractor" does not include a municipality or any other political subdivision of the state, including any entities or associations duly created by the municipality or political subdivision exclusively amongst themselves to further any purpose authorized by statute or charter, or an employee in the executive or legislative branch of state government or a quasi-public agency, whether in the classified or unclassified service and full or part-time, and only in such person's capacity as a state or quasi-public agency employee.

"Prospective state contractor" means a person, business entity or nonprofit organization that (i) submits a response to a state contract solicitation by the state, a state agency or a quasi-public agency, or a proposal in response to a request for proposals by the state, a state agency or a quasi-public agency, until the contract has been entered into, or (ii) holds a valid prequalification certificate issued by the Commissioner of Administrative Services under section 4a-100. "Prospective state contractor" does not include a municipality or any other political subdivision of the state, including any entities or associations duly created by the municipality or political subdivision exclusively amongst themselves to further any purpose authorized by statute or charter, or an employee in the executive or legislative branch of state government or a quasi-public agency, whether in the classified or unclassified service and full or part-time, and only in such person's capacity as a state or quasi-public agency employee.

"Principal of a state contractor or prospective state contractor" means (i) any individual who is a member of the board of directors of, or has an ownership interest of five per cent or more in, a state contractor or prospective state contractor, which is a business entity, except for an individual who is a member of the board of directors of a nonprofit organization, (ii) an individual who is employed by a state contractor or prospective state contractor, which is a business entity, as president, treasurer or executive vice president, (iii) an individual who is the chief executive officer of a state contractor or prospective state contractor, which is not a business entity, or if a state contractor or prospective state contractor has no such officer, then the officer who duly possesses comparable powers and duties, (iv) an officer or an employee of any state contractor or prospective state contractor who has *managerial or discretionary responsibilities with respect to a state contract*, (v) the spouse or a *dependent child* who is eighteen years of age or older of an individual described in this subparagraph, or (vi) a political committee established or controlled by an individual described in this subparagraph or the business entity or nonprofit organization that is the state contractor or prospective state contractor.

"State contract" means an agreement or contract with the state or any state agency or any quasi-public agency, let through a procurement process or otherwise, having a value of fifty thousand dollars or more, or a combination or series of such agreements or contracts having a value of one hundred thousand dollars or more in a calendar year, for (i) the rendition of services, (ii) the furnishing of any goods, material, supplies, equipment or any items of any kind, (iii) the construction, alteration or repair of any public building or public work, (iv) the acquisition, sale or lease of any land or building, (v) a licensing arrangement, or (vi) a grant, loan or loan guarantee. "State contract" does not include any agreement or contract with the state, any state agency or any quasi-public agency that is exclusively federally funded, an education loan or a loan to an individual for other than commercial purposes.

"State contract solicitation" means a request by a state agency or quasi-public agency, in whatever form issued, including, but not limited to, an invitation to bid, request for proposals, request for information or request for quotes, inviting bids, quotes or other types of submittals, through a competitive procurement process or another process authorized by law waiving competitive procurement.

"Managerial or discretionary responsibilities with respect to a state contract" means having direct, extensive and substantive responsibilities with respect to the negotiation of the state contract and not peripheral, clerical or ministerial responsibilities.

"Dependent child" means a child residing in an individual's household who may legally be claimed as a dependent on the federal income tax of such individual.

"Solicit" means (A) requesting that a contribution be made, (B) participating in any fund-raising activities for a candidate committee, exploratory committee, political committee or party committee, including, but not limited to, forwarding tickets to potential contributors, receiving contributions for transmission to any such committee or bundling contributions, (C) serving as chairperson, treasurer or deputy treasurer of any such committee, or (D) establishing a political committee for the sole purpose of soliciting or receiving contributions for any committee. Solicit does not include: (i) making a contribution that is otherwise permitted by Chapter 155 of the Connecticut General Statutes; (ii) informing any person of a position taken by a candidate for public office or a public official, (iii) notifying the person of any activities of, or contact information for, any candidate for public office; or (iv) serving as a member in any party committee or as an officer of such committee that is not otherwise prohibited in this section.

**REQUEST FOR BIDS
FOR
REFURBISHMENT OF BELT CONVEYORS CV-123/223
AT THE
MID-CONNECTICUT WASTE PROCESSING FACILITY**

SECTION 13

NOTICE OF AWARD



NOTICE OF AWARD

TO: [NAME OF SUCCESSFUL BIDDER CONTACT]
[NAME OF SUCCESSFUL BIDDER FIRM]
[ADDRESS OF SUCCESSFUL BIDDER]

PROJECT: Mid-Connecticut

RFB NO.: FY09-OP-009

CONTRACT: Refurbishment Of Belt Conveyors CV-123/223 At The Mid-Connecticut Waste Processing Facility

The Connecticut Resources Recovery Authority (“CRRA”) has considered the Bid submitted by you dated [DATE] in response to CRRA’s Notice To Contractors – Invitation To Bid for the above-referenced Work, which Work is more particularly described in the Refurbishment Of Belt Conveyors CV-123/223 At The Mid-Connecticut Waste Processing Facility Agreement (the “Work”).

You are hereby notified that your firm has been selected to perform the Work at the Mid-Connecticut Waste Processing Facility. The amount of the award for the Work is as specified in **Exhibit D** of the Agreement.

Within ten (10) days from the date of this Notice of Award you are required to:

- (a) Execute the required number of the attached counterparts of the non-negotiable Agreement and deliver such executed counterparts to CRRA;
- (b) Execute the attached Contractor’s Certification Concerning Gifts and deliver such executed Certification to CRRA;
- (c) Deliver to CRRA the requisite certificates of insurance;
- (d) Deliver to CRRA copies of the requisite Connecticut Department of Consumer Protection license numbers R7 and R8 held by employees who will be assigned to perform the Work;

- (e) Deliver to CRRA all other Contract Documents attached to the Notice Of Award; and
- (f) Satisfy all other conditions set forth herein.

As you have agreed, the terms and conditions of the Agreement, as attached, are non-negotiable.

If you fail within ten (10) days from the date of this Notice Of Award to perform and complete any of your obligations set forth in items (a) through (e) above, CRRA will be entitled to consider all your rights arising out of CRRA's acceptance of your Bid as abandoned and terminated. CRRA will also be entitled to such other rights and remedies as may be granted at law or in equity.

You are required to acknowledge your receipt of this Notice Of Award by signing below and returning the same to CRRA at the following address:

Connecticut Resources Recovery Authority
100 Constitution Plaza, 6th Floor
Hartford, CT 06103
Attention: Ronald Gingerich

Dated this [DAY] day of [MONTH], 2009.

Connecticut Resources Recovery Authority

By: _____
[NAME OF CRRA OFFICIAL]
Title: [TITLE OF CRRA OFFICIAL]

ACCEPTANCE OF NOTICE

Receipt of this NOTICE OF AWARD is hereby acknowledged this _____ day of _____, 2009.

By:

Signature: _____

Name (print/type): _____

Title: _____

ATTACHMENT A

To

NOTICE OF AWARD

**CONTRACTORS CERTIFICATION CONCERNING
GIFTS**



**CONTRACTOR'S CERTIFICATION
CONCERNING GIFTS**

**REFURBISHMENT OF BELT CONVEYORS CV-123/223
AT THE**

MID-CONNECTICUT WASTE PROCESSING FACILITY

(This CERTIFICATION is to be signed by an authorized officer of the Contractor or the Contractor's managing general partner.)

Section 4-252 of the *Connecticut General Statutes* requires that a Contractor (i.e., the successful bidder/proposer for an Agreement) complete and properly execute this Certification Concerning Gifts at the same time that the Contractor executes the Agreement. If the Contractor fails to make the required certifications, the Contractor shall be disqualified for the Agreement.

I, _____, a duly authorized officer and/or representative
of _____ (firm name)
(the "Contractor"), being duly sworn, hereby depose and say that:

1. I am over eighteen (18) years of age and believe in the obligations of an oath; and
2. The Contractor has submitted a bid/proposal for the Refurbishment Of Belt Conveyors CV-123/223 At The Mid-Connecticut Waste Processing Facility Agreement (the "Agreement") to the Connecticut Resources Recovery Authority ("CRRA"), has been selected by CRRA as the successful bidder/proposer for the Agreement and is prepared to enter into the Agreement with CRRA; and
3. No gifts were made between July 1, 2008 and the date of execution of the Agreement, by
 - (a) The Contractor,
 - (b) Any principals and key personnel of the Contractor who participated substantially in preparing the Contractor's bid/proposal for or the negotiation of the Agreement, or
 - (c) Any agent of the Contractor or principals and key personnel who participated substantially in preparing the Contractor's bid/proposal for or the negotiation of the Agreement

to

- (1) Any public official or employee of CRRA who participated substantially in the preparation of the bid/proposal solicitation for or the negotiation or award of the Agreement (such CRRA employees are listed in Table 2 below), or
- (2) Any public official or state employee of any state agency who has supervisory or appointing authority over CRRA (such public officials and state employees are listed in Table 3 below); and

4. No such principals and key personnel of the Contractor or agent of the Contractor or principals and key personnel knows of any action by Contractor to circumvent the prohibition on gifts by providing for any other principals and key personnel, official, employee or agent of the Contractor to provide a gift to any such public official or state employee; and
5. The Contractor made the bid/proposal for the Agreement without fraud or collusion with any person;
6. The information set forth herein is true, to the best of my knowledge and belief, subject to the penalties of false statement.

TABLE 2: CRRA Substantial Participants in the Preparation of the Request for Bids/Proposals for the Agreement

Richard Kowalski, Operations Engineer
Michael Tracey, Director of Operations

TABLE 3: Public Officials and State Employees of State Agencies Who Have Supervisory or Appointing Authority over CRRA

Governor M. Jodi Rell
Senator Donald E. Williams, Jr., President Pro Tempore of the Senate
Senator John McKinney, Minority Leader of the Senate
Representative James A. Amann, Speaker of the House of Representatives
Representative Lawrence F. Cafero, Jr., Minority Leader of the House of Representatives

Signature: _____

Name (type/print): _____

Title: _____

State Of: _____

County Of: _____

_____, being fully sworn, deposes and says that he/she is the _____ (Title) of _____ (Firm Name), the Contractor herein, that he/she has read the foregoing statement concerning gifts, and, under the penalty of perjury, certifies that each and every part of said statement is true to his/her best knowledge and belief.

Sworn to before me this _____ day of _____, 200__

Notary Public/Commissioner of the Superior Court

For the purposes of this Certification Concerning Gifts, the following terms are defined as follows:

"Gift" means anything of value, which is directly and personally received, unless consideration of equal or greater value is given in return. "Gift" shall not include:

- (1) A political contribution otherwise reported as required by law or a donation or payment as described in subdivision (9) or (10) of subsection (b) of section 9-333b of the *Connecticut General Statutes*;
- (2) Services provided by persons volunteering their time, if provided to aid or promote the success or defeat of any political party, any candidate or candidates for public office or the position of convention delegate or town committee member or any referendum question;
- (3) A commercially reasonable loan made on terms not more favorable than loans made in the ordinary course of business;
- (4) A gift received from (A) an individual's spouse, fiance or fiancée, (B) the parent, brother or sister of such spouse or such individual, or (C) the child of such individual or the spouse of such child;
- (5) Goods or services (A) which are provided to the state (i) for use on state property, or (ii) to support an event or the participation by a public official or state employee at an event, and (B) which facilitate state action or functions. As used in this Affidavit Concerning Gifts, "state property" means (i) property owned by the state, or (ii) property leased to an agency in the Executive or Judicial Department of the state;
- (6) A certificate, plaque or other ceremonial award costing less than one hundred dollars;
- (7) A rebate, discount or promotional item available to the general public;
- (8) Printed or recorded informational material germane to state action or functions;
- (9) Food or beverage or both, costing less than fifty dollars in the aggregate per recipient in a calendar year, and consumed on an occasion or occasions at which the person paying, directly or indirectly, for the food or beverage, or his representative, is in attendance;
- (10) Food or beverage or both, costing less than fifty dollars per person and consumed at a publicly noticed legislative reception to which all members of the General Assembly are invited and which is hosted not more than once in any calendar year by a lobbyist or business organization. For the purposes of such limit, (A) a reception hosted by a lobbyist who is an individual shall be deemed to have also been hosted by the business organization which he owns or is employed by, and (B) a reception hosted by a business organization shall be deemed to have also been hosted by all owners and employees of the business organization who are lobbyists. In making the calculation for the purposes of such fifty-dollar limit, the donor shall divide the amount spent on food and beverage by the number of persons whom the donor reasonably expects to attend the reception;
- (11) Food or beverage or both, costing less than fifty dollars per person and consumed at a publicly noticed reception to which all members of the General Assembly from a region of the state are

invited and which is hosted not more than once in any calendar year by a lobbyist or business organization. For the purposes of such limit, (A) a reception hosted by a lobbyist who is an individual shall be deemed to have also been hosted by the business organization which he owns or is employed by, and (B) a reception hosted by a business organization shall be deemed to have also been hosted by all owners and employees of the business organization who are lobbyists. In making the calculation for the purposes of such fifty-dollar limit, the donor shall divide the amount spent on food and beverage by the number of persons whom the donor reasonably expects to attend the reception. As used in this subdivision, "region of the state" means the established geographic service area of the organization hosting the reception;

- (12) Gifts costing less than one hundred dollars in the aggregate or food or beverage provided at a hospitality suite at a meeting or conference of an interstate legislative association, by a person who is not a registrant or is not doing business with the state of Connecticut;
- (13) Admission to a charitable or civic event, including food and beverage provided at such event, but excluding lodging or travel expenses, at which a public official or state employee participates in his official capacity, provided such admission is provided by the primary sponsoring entity;
- (14) Anything of value provided by an employer of (A) a public official, (B) a state employee, or (C) a spouse of a public official or state employee, to such official, employee or spouse, provided such benefits are customarily and ordinarily provided to others in similar circumstances; or
- (15) Anything having a value of not more than ten dollars, provided the aggregate value of all things provided by a donor to a recipient under this subdivision in any calendar year shall not exceed fifty dollars.

"Participated substantially" means participation that is direct, extensive and substantive, and not peripheral, clerical or ministerial.

"Principals and key personnel" means officers, directors, shareholders, members, partners and managerial employees.

**REQUEST FOR BIDS
FOR
REFURBISHMENT OF BELT CONVEYORS CV-123/223
AT THE
MID-CONNECTICUT WASTE PROCESSING FACILITY**

**SECTION 14
NOTICE TO PROCEED**



NOTICE TO PROCEED

TO: [NAME OF CONTRACTOR CONTACT]
[NAME OF CONTRACTOR FIRM]
[ADDRESS OF CONTRACTOR]

PROJECT: Mid-Connecticut

CONTRACT NO.: [TO BE ADDED LATER BY CRRA]

CONTRACT: Refurbishment Of Belt Conveyors CV-123/223 At The Mid-Connecticut Waste Processing Facility

You are hereby notified to commence the Work related to Refurbishment Of Belt Conveyors CV-123/223 at the Mid-Connecticut Waste Processing Facility in accordance with the Agreement, dated [DATE OF AGREEMENT], and that the Contract Time under the Agreement will commence to run on [DATE CONTRACT TIME STARTS]. By this date, you are to start performing the Work required by the Contract Documents. Pursuant to the Agreement, the date for completing all of the Work related to Refurbishment of Belt Conveyors CV-123/223 at the Mid-Connecticut Waste Processing Facility and having such Work ready for CRRA's acceptance is as follows:

Completion Date: [COMPLETION DATE]

You are required to acknowledge your receipt of this Notice To Proceed by signing below and returning such receipted Notice To Proceed to CRRA at the following address:

Connecticut Resources Recovery Authority
100 Constitution Plaza, 6th Floor
Hartford, CT 06103
Attention: Ronald Gingerich

Dated this [DAY] day of [MONTH], 2009.

Connecticut Resources Recovery Authority

By: _____
[NAME OF CRRA OFFICIAL]
Title: [TITLE OF CRRA OFFICIAL]

ACCEPTANCE OF NOTICE

Receipt of this NOTICE TO PROCEED is hereby acknowledged this _____ day of _____, 2009.

By:

Signature: _____

Name (print/type): _____

Title: _____

**REQUEST FOR BIDS
FOR
REFURBISHMENT OF BELT CONVEYORS CV-123/223
AT THE
MID-CONNECTICUT WASTE PROCESSING FACILITY**

**SECTION 15
REFURBISHMENT OF BELT CONVEYORS
CV-123/223 AT THE
MID-CONNECTICUT WASTE PROCESSING
FACILITY AGREEMENT**

REFURBISHMENT OF BELT CONVEYORS CV-123/223 AT THE MID-CONNECTICUT WASTE PROCESSING FACILITY AGREEMENT

CONTENTS

PRELIMINARY STATEMENT	3
1. DEFINITIONS, CONSTRUCTION AND INTERPRETATION	3
1.1 Definitions	3
1.2 Construction And Interpretation	4
2. SCOPE OF WORK	5
2.1 Contractor's Responsibilities	5
2.2 Performance and Completion of Work	6
2.3 CRRA's Responsibilities	6
2.4 Direction of Work	6
2.5 CRRA's Inspection Rights	6
2.6 Access	7
2.7 Change in Scope of Work	7
2.8 Site and Subsurface Conditions	7
2.9 Proprietary Information	8
2.10 Books and Records	8
2.11 Status of Contractor	8
2.12 Subcontractors	9
2.13 Contractor's Employees	9
2.14 Mechanic's Liens	9
3. COMPENSATION AND PAYMENT	10
3.1 Compensation	10
3.2 Payment Procedure	10
3.3 Accounting Obligations	11
3.4 Withholding Taxes And Other Payments	11
3.5 State of Connecticut Taxes	11
4. TERM OF AGREEMENT	12
4.1 Term	12
4.2 Time is of the Essence	12
4.3 Termination	12
4.4 Restoration	13
5. INDEMNIFICATION	13
5.1 Contractor's Indemnity	13
5.2 Workmanship and Materials Warranty; Other Warranties and Guarantees	14
6. INSURANCE	14
6.1 Required Insurance	14
6.2 Certificates	15
6.3 Specific Requirements	15
6.4 Issuing Companies	16
6.5 Contractor's Subcontractors	16
6.6 No Limitation on Liability	16
6.7 Other Conditions	16

7.	SECURITY FOR FAITHFUL PERFORMANCE	16
7.1	Required Security	16
7.2	Submission Of Security	17
7.3	Specific Requirements – Performance Bond and Payment Bond	17
7.4	Specific Requirements – Performance Letter Of Credit	17
7.5	Failure To Maintain The Security	17
7.6	Exercise Of Rights And Remedies	17
7.7	Issuing Companies	18
8.	MISCELLANEOUS	18
8.1	Non-Discrimination	18
8.2	Entire Agreement	19
8.3	Governing Law	19
8.4	Assignment	19
8.5	No Waiver	19
8.6	Modification	19
8.7	Prevailing Wages	20
8.8	Notices	20
8.9	Benefit and Burden	21
8.10	Severability	21
8.11	Counterparts	21
8.12	Campaign Contribution And Solicitation Prohibitions	21
8.13	Certification Concerning Nondiscrimination	21
8.14	Contractor’s Certification Concerning Gifts	22
8.15	President’s Certification Concerning Gifts	22
	EXHIBIT A – Project Specifications	A-1
	EXHIBIT B – Drawings	B-1
	EXHIBIT C – Project Schedule	C-1
	EXHIBIT D – Compensation Schedule	D-1
	EXHIBIT E – Performance Bond Form and Letter Of Credit Form	E-1
	EXHIBIT F – Payment Bond	F-1
	EXHIBIT G – Prevailing Wage Bid Package	G-1
	EXHIBIT H – Schedule Of Prevailing Wages	H-1
	EXHIBIT I – SEEC Form 11, Notice To Executive Branch State Contractors And Prospective State Contractors Of Campaign Contribution And Solicitation Ban	I-1
	EXHIBIT J – Certification Concerning Nondiscrimination	J-1
	EXHIBIT K – Contractor’s Certification Concerning Gifts	K-1
	EXHIBIT L – CRRRA President’s Certification Concerning Gifts	L-1

This **REFURBISHMENT OF BELT CONVEYORS CV-123/223 AT THE MID-CONNECTICUT WASTE PROCESSING FACILITY AGREEMENT** (“Agreement”) is made and entered into as of this ___ day of _____, 2009 by and between the **CONNECTICUT RESOURCES RECOVERY AUTHORITY**, a body politic and corporate, constituting a public instrumentality and political subdivision of the State of Connecticut, having its principal offices at 100 Constitution Plaza, 6th Floor, Hartford, Connecticut 06103 (hereinafter “CRRA” or “Owner”) and **[NAME OF SUCCESSFUL BIDDER]**, having its principal offices at **[ADDRESS OF SUCCESSFUL BIDDER]** (hereinafter “Contractor”).

PRELIMINARY STATEMENT

WHEREAS CRRA owns a certain parcel of real property located at 300 Maxim Road, Gate 70, in Hartford, Connecticut (the “Property”), upon which property CRRA operates the Mid-Connecticut Waste Processing Facility (the “Facility”).

WHEREAS CRRA now desires to enter into this Agreement with Contractor in order for Contractor to refurbish belt conveyors CV-123/223 at the Facility within the boundaries of the Property, and other related work, in accordance with the Contract Documents (the “Project”).

NOW, THEREFORE, in consideration of the mutual covenants, promises, and representations contained herein, and for other good and valuable consideration, the receipt and sufficiency of which are hereby acknowledged, the parties hereto agree as follows.

1. DEFINITIONS, CONSTRUCTION AND INTERPRETATION

1.1 Definitions

As used in this Agreement and in other Contract Documents (as defined herein) the following terms shall have the meanings as set forth below:

- (a) **“Addenda”** means written or graphic documents issued prior to the bid due date, which clarify, correct or change any or all of the Contract Documents.
- (b) **“Acceptance Date”** means the date on which CRRA determines that the Work (as defined herein) has been completed by Contractor in accordance with the Contract Documents.
- (c) **“Contract Documents”** means this Agreement (including all exhibits attached hereto), Notice To Contractors - Invitation To Bid, Instructions To Bidders, Addenda, Contractor’s bid (including all documentation accompanying such bid, all other documentation submitted in connection with such bid, and all post-bid documentation submitted prior to the Notice Of Award), Notice Of Award, the Notice To Proceed (as defined herein), the Security For Faithful Performance (as defined herein), the Drawings (as defined herein), any written amendments to

any of the Contract Documents and any change order issued pursuant to Section 2.7 and/or 8.6 hereof.

- (d) **“Contract Time”** means the number of days or the date, as set forth in **Exhibit C** of this Agreement, to perform and complete the Work and have such Work ready for CRRA’s acceptance.
- (e) **“Effective Date”** means the date set forth above in this Agreement.
- (f) **“Engineer”** means a dully authorized agent of CRRA.
- (g) **“Laws And Regulations”** means any and all applicable current or future laws, rules, regulations, ordinances, codes, orders and permits of any and all federal, state and local governmental and quasi-governmental bodies, agencies, authorities and courts having jurisdiction.
- (h) **“Notice Of Award”** means written notification from CRRA to the apparent successful bidder which states that CRRA has accepted such bidder’s bid and sets forth the remaining conditions that must be fulfilled by such bidder before CRRA executes the Agreement.
- (i) **“Owner”** means CRRA.
- (j) **“Owner’s Designee”** or **“Owner’s Representative”** means Engineer.
- (k) **“Site”** means those areas of the Property upon which the Work is to be performed, furnished and completed by Contractor in accordance with the Contract Documents.

1.2 Construction And Interpretation

For purposes of this Agreement:

- (a) Capitalized terms used herein shall have the meanings set forth herein;
- (b) Whenever nouns or pronouns are used in this Agreement, the singular shall mean the plural, the plural shall mean the singular, and any gender shall mean all genders or any other gender, as the context may require;
- (c) Words that have well-known technical or trade meanings are used herein in accordance with such recognized meanings unless otherwise specifically provided;
- (d) All accounting terms not otherwise defined herein have the meanings assigned to them in accordance with “generally accepted accounting principles,” and the term “generally accepted accounting principles” with respect to any computation required or permitted hereunder shall mean such accounting principles that are generally accepted as of the Effective Date of this Agreement;

- (e) The words “herein”, “hereof” and “hereunder” and words of similar import refer to this Agreement as a whole and not to any particular Article, Section or Sub-section;
- (f) Reference to any particular party shall include that party’s employees and the authorized agents of that party;
- (g) All references to agreements are references to the agreements as the provisions thereof that may be amended, modified or waived from time to time; and,
- (h) The captions contained in this Agreement have been inserted for convenience only and shall not affect or be effective to interpret, change or restrict the terms of provisions of this Agreement.

2. SCOPE OF WORK

2.1 Contractor’s Responsibilities

Contractor shall be responsible for [This section will, if necessary, be modified to accurately reflect the alternative CRRA has selected for the various parts of the Work]:

- (a) Providing the parts and installing the parts for the refurbishment of Belt Conveyors CV-123/223 at the Facility;
- (b) Performing all other work required for the Project, all of which is in accordance with and as required by the Contract Documents, including but not limited to, the project specifications set forth in **Exhibit A** attached hereto and made a part hereof (the “Project Specifications”) and the drawings set forth in **Exhibit B** attached hereto and made a part hereof (the “Drawings”);
- (c) Furnishing all labor, materials, supplies, tools, equipment and other facilities and necessary appurtenances or property for or incidental to the Project and the performance and completion of the Work (as hereinafter defined);
- (d) Restoring any part of the Property, the improvements thereon, including but not limited to any access roads, or the Work (as hereinafter defined) that require restoration pursuant to the terms and conditions in Section 4.4 hereof; and
- (e) Making all required notifications and obtaining all local, state, and federal permits and approvals necessary for the completion of the Work.

Items (a) through (e) above are hereinafter collectively referred to as the “Work.”

2.2 Performance and Completion of Work

All Work shall be performed and completed by Contractor in a good workmanlike manner consistent and in accordance with:

- (a) Any and all instructions, guidance and directions provided by CRRA or Engineer to Contractor;
- (b) The Contract Documents;
- (c) Sound practices for providing and installation of parts for conveyor systems;
- (d) The highest industry standards applicable to Contractor and its performance of the Work hereunder;
- (e) The schedule for the Work set forth in **Exhibit C** attached hereto and made a part hereof; and
- (f) All Laws And Regulations.

Items (a) through (f) above are hereinafter collectively referred to as the "Standards."

Contractor shall obtain any locally required building or other permits required for the Work, and Contractor shall also assist and fully cooperate with CRRA in obtaining any other applicable permits necessary to begin and complete the Work.

2.3 CRRA's Responsibilities

CRRA and/or its Engineer shall be responsible for administering this Agreement, accepting the Work that is performed and completed by Contractor in accordance with the Contract Documents, and receiving and paying invoices for such Work.

2.4 Direction of Work

CRRA and/or its Engineer may, where necessary or desired, provide Contractor with instructions, guidance and directions in connection with Contractor's performance of the Work hereunder. CRRA reserves the right to determine whether Contractor will, upon completion of any phase of the Work, proceed to any or all remaining phases of the Work. If CRRA determines that Contractor shall not proceed with the remaining Work, CRRA shall terminate this Agreement in accordance with Section 4.3 hereof.

2.5 CRRA's Inspection Rights

Contractor's performance of the Work hereunder, as well as Contractor's work products resulting from such performance, are subject to inspection by CRRA. Inspections may be conducted at any time by CRRA. In the event of an inspection, Contractor shall provide to CRRA any documents or other materials that may be necessary in order for CRRA to conduct the inspection. If, after any such inspection, CRRA is unsatisfied with Contractor's per-

formance of the Work hereunder or any of the work products resulting therefrom, Contractor shall, at the direction of CRRA, render such performance or work products satisfactory to CRRA at no additional cost or expense to CRRA and without any extension of or addition to any Contract Time for the remaining Work. For purpose of this Section 2.5, CRRA shall mean CRRA and/or its authorized agents, including but not limited to Engineer.

2.6 Access

CRRA hereby grants to Contractor, during such times as directed by CRRA and/or its Engineer, access to only those areas of the Property necessary for Contractor to perform the Work hereunder, provided that:

- (a) Contractor shall not interfere with any other operations or activities being conducted on the Property by either CRRA or any other person or entity;
- (b) Contractor directly coordinates with CRRA and/or its Engineer on such access and Contractor's storage of any equipment or materials on the Property; and
- (c) Contractor is in compliance with all of the terms and conditions of this Agreement.

CRRA reserves the right to revoke the access granted to Contractor herein if Contractor fails to comply with any of the foregoing conditions of access.

2.7 Change in Scope of Work

In the event that CRRA determines during the term of this Agreement that any revisions, modifications or changes are necessary to the scope of Work as set forth in Section 2.1 hereof, then pursuant to CRRA's request, Contractor shall promptly commence and perform the work required for such revisions, modifications or changes, which work shall be performed in accordance with the Standards unless otherwise specifically agreed to in writing by CRRA and Contractor. If any adjustment(s) to the Contract Price and/or the Contract Time is required as a result of such revisions, modifications or changes, CRRA and Contractor shall mutually agree in writing on the amount of such adjustment(s) provided that the schedule of values (including the unit prices set forth therein) approved by CRRA for the Project, to the extent applicable, shall be used to determine the appropriate increase or decrease in the quantity or cost of the materials or Work necessitated by such revisions, modifications or changes. Contractor shall promptly commence and perform any work required by such revisions, modifications or changes even if CRRA and Contractor cannot agree on the amount of such adjustment(s).

2.8 Site and Subsurface Conditions

All information and data shown or indicated in the Contract Documents with respect to underground facilities, surface conditions, subsurface conditions or other conditions at or contiguous to the Site are furnished for information only and CRRA does not assume any responsibility for the accuracy or completeness of such information and data. Contractor acknowl-

edges and agrees that CRRA does not assume any responsibility for such information and data and that Contractor is solely responsible for investigating and satisfying itself as to all actual and existing Site conditions, including but not limited to surface conditions, subsurface conditions and underground facilities. Contractor has carefully studied all such information and data and Contractor has obtained and carefully studied (or assumes responsibility for having done so) all such additional or supplementary examinations, investigations, explorations, tests, studies and data concerning conditions (including but not limited to surface conditions, subsurface conditions and underground facilities) at or contiguous to the Site and all other conditions or factors which may affect cost, progress, performance, furnishing or completion of the Work or which relate to any aspect of the means, methods, techniques, sequences, and procedures of construction or performance of the Work to be employed by Contractor and safety precautions and programs incident thereto. Contractor does not consider that any additional examinations, investigations, explorations, tests, studies or data are necessary for Contractor to conclusively determine, and Contractor has so determined, that the Work can be performed, furnished and completed in accordance with the Contract Time, the Contract Price and the other terms and conditions of the Contract Documents. In the event that the information or data shown or indicated in the Contract Documents with respect to underground facilities or surface, subsurface or other conditions at or contiguous to the Site differs from conditions encountered by Contractor during performance of the Work, there shall be no increase in the Contract Price and/or no extension of the Contract Time as a result of such differing conditions, unless CRRA, in its sole and absolute discretion, agrees in writing to such increase and/or extension.

2.9 Proprietary Information

Contractor shall not use, publish, distribute, sell or divulge any information obtained from CRRA by virtue of this Agreement for Contractor's own purposes or for the benefit of any person, firm, corporation or other entity (other than CRRA) without the prior written consent of CRRA. Any report or other work product prepared by Contractor in connection with the performance of the Work hereunder shall be owned solely and exclusively by CRRA and cannot be used by Contractor for any purpose beyond the scope of this Agreement without the prior written consent of CRRA.

2.10 Books and Records

Contractor shall maintain proper books and records containing complete and correct information on all Work performed by Contractor pursuant to this Agreement in accordance with generally accepted accounting principles and practices. CRRA has the right to inspect and review all such books and records during Contractor's business hours.

2.11 Status of Contractor

CRRA and Contractor acknowledge and agree that Contractor is acting as an independent contractor in performing any Work for CRRA hereunder and that Contractor shall perform such Work in its own manner and method subject to the terms of this Agreement. Nothing in this Agreement shall be construed or interpreted as creating a partnership, a joint venture, an

agency, a master-servant relationship, an employer-employee relationship or any other relationship between CRRA and Contractor other than that of an owner and an independent contractor. Contractor is expressly forbidden from transacting any business in the name of or on account of CRRA, and Contractor has no power or authority to assume or create any obligation or responsibility for or on behalf of CRRA in any manner whatsoever.

2.12 Subcontractors

Contractor shall consult with CRRA before hiring any subcontractors to perform any Work hereunder. Contractor shall require all of its subcontractors to abide by the terms and conditions of this Agreement. Moreover, Contractor's subcontracts with such subcontractors shall specifically provide that, in the event of a default by Contractor thereunder or under this Agreement, CRRA may directly enforce such subcontracts and make payments thereunder. Contractor shall provide CRRA with all contracts, amendments, books, records, accounts, correspondence and other materials necessary to enforce such subcontracts. Also Contractor's subcontracts with its subcontractors shall specifically include CRRA as a third party beneficiary and shall provide that such subcontractors shall not be excused from any of their obligations under such subcontracts by reason of any claims, setoffs, or other rights whatsoever that they may have with or against Contractor other than through such subcontracts.

2.13 Contractor's Employees

All persons employed by Contractor shall be subject and responsible solely to the direction of Contractor and shall not be deemed to be employees of CRRA.

2.14 Mechanic's Liens

Contractor shall claim no interest in the Property or any equipment, fixtures or improvements located or to be located thereon, including but not limited to the Site or any part thereof. Contractor shall not file any mechanic's liens or other liens or security interests against CRRA or any of its properties, including but not limited to the Property. Contractor shall defend, indemnify and hold harmless CRRA against all costs associated with the filing of such liens or interests by Contractor or any of its subcontractors or materialmen. Before any subcontractor or materialman of Contractor commences any Work hereunder, Contractor shall deliver to CRRA an original waiver of mechanic's liens properly executed by such subcontractor or materialman. If any mechanic's lien is filed against CRRA or any of its properties in connection with the Work hereunder, Contractor shall cause the same to be canceled and discharged of record within fifteen (15) days after the filing of such lien and, if Contractor fails to do so, CRRA may, at its option but without any obligation to do so, make any payment necessary to obtain such cancellation or discharge and the cost thereof, at CRRA's election, shall be either deducted from any payment due to Contractor hereunder or reimbursed to CRRA promptly upon demand by CRRA to Contractor.

3. COMPENSATION AND PAYMENT

3.1 Compensation

The total amount of compensation to be paid to Contractor by CRRA for the Work hereunder shall not exceed the amount set forth in **Exhibit D** attached hereto and made a part hereof (the "Contract Price"), which Contract Price shall be payable as set forth in Section 3.2 below. Contractor acknowledges and agrees that the Contract Price constitutes the full compensation to Contractor for the Work to be performed by Contractor hereunder and includes all expenses and costs to be incurred by Contractor in performing such Work.

3.2 Payment Procedure

[If CRRA selects one Bidder to complete both parts of the Work, the following paragraph will be modified to provide for payment after each part of the Work (i.e., the "parts" part and the "installation part") is completed.]

After Contractor completes the Work, except for the one (1) year warranty period, Contractor shall submit to CRRA a written request for payment for all the Work completed by Contractor. The written request for payment shall include at least the following information:

- (a) A description of the work performed and materials provided;
- (b) The purchase order number for this Work (to be provided by CRRA); and
- (c) The contract number for this Agreement (to be provided by CRRA).

If CRRA determines in its sole and absolute discretion that the payment requested in the request for Payment is proper and has been completed in conformance with this Agreement, then CRRA shall pay the Contractor ninety-five percent (95%) of the amount requested (the "Authorized Percentage Sum") within thirty (30) days after CRRA's receipt of the invoice and CRRA shall withhold the remaining five (5%) percent of such amount as retainage ("Retainage"). If, however, CRRA determines that the work is unsatisfactory or not in conformance with this Agreement, then CRRA may, in its sole and absolute discretion, withhold all or a portion of the payment requested by Contractor, and Contractor shall, if requested by CRRA, immediately take, at Contractor's sole cost and expense, all action necessary to render such work in conformance with the terms of this Agreement. CRRA shall have no obligation under this Agreement to pay for any work that CRRA determines has not been performed in conformance with the terms of this Agreement. Within ten (10) days after the Acceptance Date, Contractor shall submit to CRRA a written request for payment of all Retainage, and, provided Contractor is not in default hereunder and CRRA does not dispute the amount of such requested payment, CRRA shall pay Contractor such Retainage within thirty (30) days after CRRA's receipt of such written request. CRRA shall have no obligation to pay Contractor any amounts due Contractor under this Agreement if Contractor is in default hereunder.

3.3 Accounting Obligations

Contractor shall maintain books and accounts of the costs incurred by Contractor in performing the Work pursuant to this Agreement by contract number and in accordance with generally accepted accounting principles and practices. CRRA, during normal business hours, for the duration of this Agreement, shall have access to such books and accounts to the extent required to verify such costs incurred.

3.4 Withholding Taxes And Other Payments

No FICA (social security) payroll tax, state or federal income tax, federal unemployment tax or insurance payments, state disability tax or insurance payments or state unemployment tax or insurance payments shall be paid or deposited by CRRA with respect to Contractor, nor be withheld from payment to Contractor by CRRA. No workers' compensation insurance has been or will be obtained by CRRA on account of the Work to be performed hereunder by Contractor, or any of Contractor's employees or subcontractors. Contractor shall be responsible for paying or providing for all of the taxes, insurance and other payments described or similar to those described in this Section 3.4 and Contractor hereby agrees to indemnify CRRA and hold CRRA harmless against any and all such taxes, insurance or payments, or similar costs which CRRA may be required to pay in the event that Contractor's status hereunder is determined to be other than that of an independent contractor.

3.5 State of Connecticut Taxes

Pursuant to Section 22a-270 of the *Connecticut General Statutes* (as the same may be amended or superceded from time to time), CRRA is exempt from all State of Connecticut taxes and assessments ("Connecticut Taxes"), and the payment thereof. Without limiting the generality of the preceding sentence, the sale of any services or tangible personal property to be incorporated into or otherwise consumed in the operation of a CRRA Project is exempt from Connecticut Taxes, including without limitation Connecticut sales and use taxes, whether purchased. Accordingly, Contractor shall not include in the fees, and Contractor shall not charge or pass through any Connecticut Taxes to CRRA, including that portion of any combined tax or assessment representing any Connecticut Taxes, regardless of whether Contractor has incurred any Connecticut State Taxes in its performance of the Agreement.

CRRA expresses no opinion as to the eligibility for any tax exemption, or refund or other reimbursement, including without limitation any Connecticut Taxes, with respect to tangible personal property purchased at any location for use in the performance of Work contemplated by this Agreement.

Contractor should consult with its tax advisor and/or its attorney, and the Connecticut Department of Revenue Services ("DRS") and any other applicable tax authority, with regard to such tax authorities' policies, procedures, recordkeeping and filing requirements for reimbursement of any taxes, including without limitation Connecticut Taxes, paid in the performance of Work contemplated by this Agreement, and whether or not there is a mechanism available to Contractor for the reimbursement of taxes, including without limitation Connect-

icut Taxes, paid on fuel purchased for use in the performance of the Work contemplated by this Agreement.

Contractor and CRRA agree that Contractor is and shall act as an independent contractor. Notwithstanding Contractor's status as an independent contractor, but without limiting Contractor's obligation hereunder to pay, and be solely responsible for, any Connecticut taxes levied, imposed or applicable to the Work, for the sole purpose of allowing CRRA to benefit from the aforesaid exemption, CRRA shall designate, and Contractor has agreed to act, as CRRA's agent in purchasing services and equipment, machinery, parts, materials, supplies, inventories, fuel, and other items necessary to perform the Work hereunder for the account of CRRA, and with funds provided as reimbursement therefor by CRRA.

4. TERM OF AGREEMENT

4.1 Term

The term of this Agreement shall commence upon the Effective Date and shall terminate, unless otherwise terminated or extended in accordance with the terms and provisions hereof, on the first anniversary of the Acceptance Date.

4.2 Time is of the Essence

CRRA and Contractor hereby acknowledge and agree that time is of the essence with respect to Contractor's performance of the Work hereunder. Accordingly, upon CRRA's issuance to Contractor of a notice to proceed with the Work (the "Notice To Proceed"), which Notice To Proceed shall be issued after the parties hereto receive all of the local, state and federal permits required for the Work hereunder, Contractor shall immediately commence performance of the Work and continue to perform the same during the term of this Agreement in accordance with the schedule set forth in attached **Exhibit C** in order to complete all of the Work and have such Work ready for CRRA's acceptance at the end of the number of days specified in **Exhibit C** following the issuance of such Notice To Proceed (the "Completion Date").

CRRA and Contractor recognize the difficulties involved in proving actual damages and losses suffered by CRRA if the Work is not completed and ready for CRRA's acceptance by the Completion Date. Accordingly, instead of requiring any such proof, CRRA and Contractor agree that as liquidated damages for any such delay in completion or readiness for acceptance (but not as a penalty) Contractor shall pay CRRA one hundred dollars (\$100.00) for each calendar day beyond the Completion Date that Contractor fails to complete all of the Work or have the same ready for CRRA's acceptance until all such Work is completed by Contractor and readied by Contractor for acceptance by CRRA.

4.3 Termination

CRRA may terminate this Agreement at any time by providing Contractor with ten (10) days' prior written notice of such termination. Upon receipt of such written notice from CRRA,

Contractor shall immediately cease performance of all Work, unless otherwise directed in writing by CRRA. Prior to any termination of this Agreement, Contractor shall remove all of its personnel and equipment from the Property, restore any part of the Property, any of the improvements located or to be located thereon, including but not limited to any access roads, or any of the Work that requires restoration pursuant to the terms and conditions of Section 4.4 hereof. Upon termination of this Agreement pursuant to this Section 4.3,

- (a) CRRA shall pay Contractor for all Work performed and completed by Contractor prior to the termination date, provided:
 - (1) Such Work has been performed and completed by Contractor in conformance with the Standards;
 - (2) Payment for such Work has not been previously made or is not disputed by CRRA;
 - (3) Contractor is not in default hereunder; and,
 - (4) Contractor has performed and completed all its obligations under this Section 4.3 and Section 4.4 hereof to CRRA's satisfaction, and
- (b) CRRA shall have no further liability hereunder.

Except for the payment that may be required pursuant to the preceding sentence, CRRA shall not be liable to Contractor in any other manner whatsoever in the event CRRA exercises its right to terminate this Agreement.

4.4 Restoration

Unless otherwise directed in writing by CRRA, Contractor shall:

- (a) Restore any part of the Property or any of the improvements located or to be located thereon, other than those areas of the Property or such improvements improved by Contractor pursuant to this Agreement, disturbed or damaged by Contractor or any of its directors, officers, employees, agents, subcontractors or materialmen to the same condition existing immediately prior to such disturbance or damage; and
- (b) Restore or repair any completed Work so disturbed or damaged to the condition required by the Contract Documents for acceptance of such Work by CRRA.

5. INDEMNIFICATION

5.1 Contractor's Indemnity

Contractor shall at all times defend, indemnify and hold harmless CRRA and its board of directors, officers, agents and employees from and against any and all claims, damages, losses,

judgments, liability, workers' compensation payments and expenses (including but not limited to attorneys' fees) arising out of injuries to the person (including death), damage to property or any other damages alleged to have been sustained by: (a) CRRA or any of its directors, officers, agents, employees or other contractors, or (b) Contractor or any of its directors, officers, agents, employees, subcontractors or materialmen, or (c) any other person, to the extent any such injuries, damage or damages are caused or alleged to have been caused in whole or in part by the acts, omissions or negligence of Contractor or any of its directors, officers, agents, employees, subcontractors or materialmen. Contractor further undertakes to reimburse CRRA for damage to property of CRRA caused by Contractor or any of its directors, officers, agents, employees, subcontractors or materialmen, or by faulty, defective or unsuitable material or equipment used by it or any of them. The existence of insurance shall in no way limit the scope of this indemnification. Contractor's obligations under this Section 5.1 shall survive the termination or expiration of this Agreement.

5.2 Workmanship and Materials Warranty; Other Warranties and Guarantees

For a period of one (1) year following the Acceptance Date (the "Warranty Period"), Contractor warrants the workmanship, equipment, and materials furnished under this Agreement for the Project against defects. If during or at the end of the Warranty Period, CRRA determines that any of such workmanship, equipment or materials is or has become defective, Contractor shall, at its own cost and expense, promptly repair or replace such defective workmanship, equipment or materials in order to render the same to the same condition as warranted above. Any repairs to or replacements of such workmanship, equipment or materials required under this Section 5.2 must be approved by CRRA before Contractor may commence performance of such repairs or replacements, and all such repairs or replacements shall be performed by Contractor in accordance with all applicable Standards. In connection therewith Contractor shall obtain all warranties and guarantees for all material and equipment furnished hereunder by Contractor that are assignable to CRRA. Contractor shall assign such warranties and guarantees to CRRA upon the Acceptance Date. Contractor's obligations under this Section 5.2 shall survive the termination or expiration of this Agreement.

6. INSURANCE

6.1 Required Insurance

Contractor shall procure and maintain, at its own cost and expense, throughout the term of this Agreement and any extension thereof, the following insurance, including any required endorsements thereto and amendments thereof:

- (a) Commercial General Liability insurance alone or in combination with Commercial Umbrella insurance with a limit of not less than five million dollars (\$5,000,000) each occurrence covering liability arising from premises, operations, independent contractors, products-completed operations, personal injury and advertising injury, and liability assumed under an insurance contract (including the tort liability of another assumed in a business contract).

- (b) Business Automobile Liability insurance alone or in combination with Commercial Umbrella insurance covering any auto (including owned, hired, and non-owned autos), with a limit of not less than one million dollars (\$1,000,000) each accident.
- (c) Workers' Compensation with statutory limits and Employers' Liability limits of not less than one million dollars (\$1,000,000) each accident for bodily injury by accident or one million dollars (\$1,000,000) for each employee for bodily injury by disease.
- (d) Professional Liability insurance with a limit of one million dollars (\$1,000,000) [Only for "Parts" part of the Work].

6.2 Certificates

Within five (5) days after CRRA issues the Notice Of Award, and prior to commencement of activities on site, Contractor shall submit to CRRA a certificate or certificates for each required insurance referenced in Section 6.1 above certifying that such insurance is in full force and effect and setting forth the information required by Section 6.3 below. Additionally, Contractor shall furnish to CRRA within thirty (30) days before the expiration date of the coverage of each required insurance set forth in Section 6.1 above, a certificate or certificates containing the information required by Section 6.3 below and certifying that such insurance has been renewed and remains in full force and effect.

6.3 Specific Requirements

All policies for each insurance required hereunder shall:

- (a) Name CRRA as an additional insured (this requirement shall not apply to workers' compensation insurance/employers' liability insurance or professional liability insurance) ["Professional liability insurance" will be included only for "Parts" part of the Work];
- (b) Include a standard severability of interest clause;
- (c) Provide for not less than thirty (30) days' prior written notice to CRRA by registered or certified mail of any cancellation, restrictive amendment, non-renewal or change in coverage;
- (d) Contain a waiver of subrogation holding CRRA free and harmless from all subrogation rights of the insurer; and
- (e) Provide that such required insurance hereunder is the primary insurance and that any other similar insurance that CRRA may have shall be deemed in excess of such primary insurance.

6.4 Issuing Companies

All policies for each insurance required hereunder shall be issued by insurance companies that are either licensed by the State of Connecticut and have a Best's Key Rating Guide of A-VII or better, or otherwise deemed acceptable by CRRA in its sole discretion.

6.5 Contractor's Subcontractors

Contractor shall either have its subcontractors covered under the insurance required hereunder, or require such subcontractors to procure and maintain the insurance that Contractor is required to procure and maintain under this Agreement.

6.6 No Limitation on Liability

No provision of this Article 6 shall be construed or deemed to limit Contractor's obligations under this Agreement to pay damages or other costs and expenses.

6.7 Other Conditions

CRRA shall not, because of accepting, rejecting, approving, or receiving any certificate of insurance required hereunder, incur any liability for:

- (a) The existence, non-existence, form or legal sufficiency of the insurance described on such certificate,
- (b) The solvency of any insurer, or
- (c) The payment of losses.

7. SECURITY FOR FAITHFUL PERFORMANCE

7.1 Required Security

Contractor shall procure and maintain in full force and effect, at its own cost and expense, throughout the term of this Agreement and any extension thereof, the following:

- (a) A performance bond or letter of credit (the "Performance Bond" or the "Performance Letter Of Credit") in the full amount of the Contract Price and such Performance Bond or Performance Letter Of Credit shall be in and drawn on the forms set forth in **Exhibit E** attached hereto and made a part hereof; and
- (b) A payment bond (the "Payment Bond") in the full amount of the Contract Price and such Construction Payment Bond shall be in and drawn on the form set forth in **Exhibit F** attached hereto and made a part hereof [This will be included only for the "installation" part of the Work].

7.2 Submission Of Security

Within ten (10) days after CRRA issues the Notice of Award, Contractor shall furnish CRRA with the following:

- (a) The Performance Bond or the Performance Letter Of Credit; and
- (b) The Payment Bond.

7.3 Specific Requirements – Performance Bond and Payment Bond

If the surety on the Performance Bond and/or the Payment Bond furnished by Contractor is declared a bankrupt or becomes insolvent or its right to do business is terminated in the State of Connecticut or it ceases to meet the above requirements or the surety elects not to renew the Performance Bond and/or the Payment Bond due to no fault of Contractor, Contractor shall immediately substitute another bond and surety, subject to the requirements set forth in this Article 7.

7.4 Specific Requirements – Performance Letter Of Credit

The Performance Letter Of Credit required hereunder shall be automatically renewed by Contractor on an annual basis, unless not later than ninety (90) days prior to the then current expiration date of the Performance Letter Of Credit, Contractor notifies CRRA by registered mail that the issuer of the Performance Letter Of Credit elects not to renew such Performance Letter Of Credit. If the issuer of the Performance Letter Of Credit furnished by Contractor is declared a bankrupt or becomes insolvent or its right to do business is terminated in the State of Connecticut or it ceases to meet the above requirements or the issuer elects not to renew the Performance Letter Of Credit due to no fault of Contractor, Contractor shall immediately substitute another letter of credit (or bond) and surety, subject to the requirements set forth in this Section 7.

7.5 Failure To Maintain The Security

Failure to maintain or renew the Performance Bond, the Performance Letter Of Credit and/or the Payment Bond under the aforesaid terms shall constitute a default by Contractor of this Agreement.

7.6 Exercise Of Rights And Remedies

In the event Contractor fails to perform any of its obligations under this Agreement, CRRA shall have the right, in addition to all other rights and remedies available to CRRA hereunder or otherwise, to exercise any or all of CRRA's rights and remedies under the Performance Bond, the Performance Letter Of Credit and the Payment Bond.

7.7 Issuing Companies

The Performance Bond and the Payment Bond shall be issued and executed by a surety company or companies acceptable to CRRA. The Performance Letter Of Credit shall be issued and executed by a Connecticut Bank or by a national banking association acceptable to CRRA.

8. MISCELLANEOUS

8.1 Non-Discrimination

Contractor agrees to the following:

- (a) Contractor agrees and warrants that in the performance of the Work for CRRA Contractor will not discriminate or permit discrimination against any person or group of persons on the grounds of race, color, religious creed, age, marital status, including civil union status, national origin, ancestry, sex, sexual orientation, mental retardation or physical disability, including, but not limited to, blindness, unless it is shown by Contractor that such disability prevents performance of the Work involved, in any manner prohibited by the laws of the United States or of the State of Connecticut. Contractor further agrees to take affirmative action to insure that applicants with job related qualifications are employed and that employees are treated when employed without regard to their race, color, religious creed, age, marital status, including civil union status, national origin, ancestry, sex, sexual orientation, mental retardation, or physical disability, including, but not limited to, blindness, unless it is shown by Contractor that such disability prevents performance of the Work involved;
- (b) Contractor agrees, in all solicitations or advertisements for employees placed by or on behalf of Contractor, to state that it is an “affirmative action-equal opportunity employer” in accordance with regulations adopted by the Connecticut Commission on Human Rights and Opportunities (The “Commission”);
- (c) Contractor agrees to provide each labor union or representative of workers with which Contractor has a collective bargaining agreement or other contract or understanding and each vendor with which Contractor has a contract or understanding, a notice to be provided by the Commission, advising the labor union, workers’ representative and vendor of Contractor’s commitments under Sections 4a-60 and 4a-60a of the *Connecticut General Statutes* and to post copies of the notice in conspicuous places available to employees and applicants for employment;
- (d) Contractor agrees to comply with each applicable provision of Sections 4a-60, 4a-60a, 46a-68e, and 46a-68f, inclusive, of the *Connecticut General Statutes* and

with each regulation or relevant order issued by the Commission pursuant to Sections 46a-56, 46a-68e, and 46a-68f of the *Connecticut General Statutes*; and

- (e) Contractor agrees to provide the Commission with such information requested by the Commission, and permit access to pertinent books, records and accounts concerning the employment practices and procedures of Contractor as related to the applicable provisions of Sections 4a-60, 4a-60a and 46a-56 of the *Connecticut General Statutes*. If this Agreement is a public works contract, Contractor agrees and warrants that it will make good faith efforts to employ minority business enterprises as subcontractors and suppliers of materials in such public works project.

8.2 Entire Agreement

This Agreement constitutes the entire agreement and understanding between the parties hereto and concerning the subject matter hereof, and supersedes any previous agreements, written or oral, between the parties hereto and concerning the subject matter hereof.

8.3 Governing Law

This Agreement shall be governed by, and construed, interpreted and enforced in accordance with the laws of the State of Connecticut as such laws are applied to contracts between Connecticut residents entered into and to be performed entirely in Connecticut.

8.4 Assignment

This Agreement may not be assigned in whole or in part by either party without the prior written consent of the other party or such assignment shall be void.

8.5 No Waiver

Failure to enforce any provision of this Agreement or to require at any time performance of any provision hereof shall not be construed to be a waiver of such provision, or to affect the validity of this Agreement or the right of any party to enforce each and every provision in accordance with the terms hereof. No waiver of any provision of this Agreement shall affect the right of CRRA or Contractor thereafter to enforce such provision or to exercise any right or remedy available to it in the event of any other default involving such provision or any other provision. Making payment or performing pursuant to this Agreement during the existence of a dispute shall not be deemed to be and shall not constitute a waiver of any claims or defenses of the party so paying or performing.

8.6 Modification

This Agreement may not be amended, modified or supplemented except by a writing signed by the parties hereto that specifically refers to this Agreement. Any oral representations or letters by the parties or accommodations shall not create a pattern or practice or course of

dealing contrary to the written terms of this Agreement unless this Agreement is formally amended, modified or supplemented.

8.7 Prevailing Wages

Contractor hereby represents that the Contractor's Wage Certification Form, as executed by Contractor and attached hereto as part of **Exhibit G**, which Exhibit in its entirety is made a part hereof, has been submitted by Contractor to the State of Connecticut's Department of Labor for Contractor's performance of the Work. Contractor shall pay wages on an hourly basis to any mechanic, laborer or workman employed upon the Work herein and the amount of payment or contribution paid or payable on behalf of each such employee to an employee welfare fund, as defined in *Connecticut General Statutes* § 31-53(h), at rates equal to the rates customary or prevailing for the same work in the same trade or occupation in the town in which the Work is being conducted, which rates are more specifically set forth in **Exhibit H** attached hereto and made a part hereof. If Contractor is not obligated by agreement to make payment or contribution on behalf of such employees to any such employee welfare fund, Contractor shall pay to each employee as part of his or her wages the amount of payment or contribution for his or her classification on each payday. Contractor shall keep, maintain and preserve records relating to the wages and hours worked by each employee and a schedule of the occupation or work classification at which each mechanic, laborer, or workman under this Agreement is employed during each work day and week in such manner and form as the labor commissioner establishes to assure the proper payments due to such employees or employee welfare funds under *Connecticut General Statutes* §§ 31-53 and 31-54. Pursuant to *Connecticut General Statutes* § 31-53(f), Contractor shall complete and submit to CRRA on a weekly basis during the term of this Agreement and any extension thereof the payroll certification forms also set forth in **Exhibit G**. Contractor hereby represents and covenants that it is not now, and has not been for at least three (3) years previous to the date of this Agreement, listed by the labor commissioner as a person who has violated laws and regulations relating to prevailing wages.

8.8 Notices

All notices, requests, demands and other communications hereunder shall be in writing and shall be deemed to have been duly given if mailed via certified first class mail return receipt requested postage prepaid or overnight express mail service to the pertinent address below.

(a) If to CRRA:

Connecticut Resources Recovery Authority
100 Constitution Plaza, 6th Floor
Hartford, Connecticut 06103
Attention: Richard Kowalski

With a copy to:

Connecticut Resources Recovery Authority
100 Constitution Plaza, 6th Floor
Hartford, Connecticut 06103
Attention: President

(b) If to Contractor:

Attention: _____

8.9 Benefit and Burden

This Agreement shall inure to the benefit of and be binding upon the heirs, personal representatives, successors and assigns of the parties hereto.

8.10 Severability

CRRA and Contractor hereby understand and agree that if any part, term or provision of this Agreement is held by any court to be invalid, illegal or in conflict with any applicable law, the validity of the remaining portions of this Agreement shall not be affected, and the rights and obligations of the parties shall be construed and enforced as if this Agreement did not contain the particular part, term or provision held to be invalid, illegal or in conflict with any applicable law.

8.11 Counterparts

This Agreement may be executed in any number of counterparts by the parties hereto. Each such counterpart so executed shall be deemed to be an original and all such executed counterparts shall constitute but one and the same instrument.

8.12 Campaign Contribution And Solicitation Prohibitions

For all State contracts as defined in P.A. 07-1 having a value in a calendar year of \$50,000 or more or a combination or series of such agreements or contracts having a value of \$100,000 or more, the authorized signatory to this Agreement expressly acknowledges receipt of the State Elections Enforcement Commission's notice advising state contractors of state campaign contribution and solicitation prohibitions, and will inform its principals of the contents of the notice. See Exhibit I [SEEC Form 11].

8.13 Certification Concerning Nondiscrimination

At the time the Seller submitted its bid to Buyer, it simultaneously executed a document entitled Certification Concerning Nondiscrimination and said document is attached hereto and made a part of this Agreement as Exhibit J.

8.14 Contractor's Certification Concerning Gifts

At the time of Seller's execution of this Agreement, Seller simultaneously executed a document entitled Contractor's Certification Concerning Gifts and said document is attached hereto and made a part of this Agreement as Exhibit K.

8.15 President's Certification Concerning Gifts

At the time of the President of Buyer's execution of this Agreement, the President of Buyer simultaneously executed a document entitled President's Certification Concerning Gifts and said document is attached hereto and made a part of this Agreement as Exhibit L.

IN WITNESS WHEREOF, the parties hereto have set their hands and seals as of the day and year first written above.

CONNECTICUT RESOURCES RECOVERY AUTHORITY

By: _____
Thomas D. Kirk
Its President
Duly Authorized

CONTRACTOR

By: _____
Its
Duly Authorized

EXHIBIT A

To

**REFURBISHMENT OF BELT CONVEYORS CV-123/223
AT THE
MID-CONNECTICUT WASTE PROCESSING FACILITY
AGREEMENT**

PROJECT SPECIFICATIONS

EXHIBIT A

PROJECT SPECIFICATIONS

REFURBISHMENT OF CONVEYORS CV-123/223 AT THE MID-CONNECTICUT WASTE PROCESSING FACILITY

1. PLANT OPERATION

Connecticut Resources Recovery Authority (“CRRA”) owns the Mid-Connecticut Resource Recovery Facility (“RRF”), which is a waste-to-energy facility. The Mid-Connecticut RRF includes the Waste Processing Facility (“WPF”) located at 300 Maxim Road, Hartford Connecticut, which is the facility where Municipal Solid Waste (“MSW”) is converted into Refuse Derived Fuel (“RDF”). The WPF is operated by the Metropolitan District Commission (the “District”) under contract to CRRA.

At the WPF, MSW is fed onto a series of conveyors and from there the waste is processed by a series of process equipment, which size the material into a burnable product, removing recyclables and other unwanted material from the waste stream. The WPF has two processing lines that are identical to each other and that are designated by CRRA as processing line 1 and processing line 2. Along each processing line there are primary trommels that are specifically designed to remove approximately one inches and under sized MSW material producing RDF. The primary trommels have dedicated takeaway conveyors for this sized material; the conveyors have the equipment number of CV-123 and CV-223.

2. SCOPE OF WORK

The Contractor will supply all materials, equipment, and labor to replace all parts (except the base frame) that would convert the existing primary trommel takeaway conveyors CV-123 and CV-223 into troughed conveyors as described below:

- (a) Replacement of all rotating components of CV-123 and CV-223. This includes all trough supply idlers, tail and head shaft assemblies, replacement of up-turn wheels and bend pulley assembly.
- (b) Replacement of all non-rotating components of CV-123 and CV-223. This includes removal and re-installation of all sidewalls along with new side skirting systems. New sidewalls are to be fabricated and painted by contractor.
- (c) Both CV-123 and CV-223 shall receive new belts. Both CV-123 and CV-223 splices shall be hot vulcanized.
- (d) Fabrication and installation of new drop chutes into CV-123 and CV-223 from primary trommels.

- (e) Contractor to replace all top deck sheet steel on both CV-123 and CV-223.
- (f) Contractor to verify dimensions on the supplied drawings by field measurement, to produce fabrication drawings and to revise these drawings, as necessary, into as-built drawings that are to be turned over to the CRRA and District after installation.
- (g) Painting of all new sidewall material and top deck steel supplied by Contractor (see **Exhibit B** for specifications).
- (h) The Contractor shall proceed with the installation of the new materials after the inventory of all fabricated sections are on the site. Any pre-assembly that is required shall be complete prior to commencing the work.

2.1 Engineering

CRRA-supplied drawings may be utilized as a reference. A field measurement by the Contractor is mandatory. The drawings supplied by the CRRA are for reference only; exact dimensions need to be verified by the Contractor. The Contractor shall submit fabrication drawings for review by the District and CRRA. The CRRA and District will review and return the fabrication drawings to the Contractor for revisions as necessary. The CRRA and District Engineers shall sign the revised drawings before fabrication can proceed. The Contractor must have these signed fabrication drawings to perform the work. The approved as-built drawings are to be turned over to the CRRA and District after installation.

CV-123 and CV-223 shall be available after processing has been completed during maintenance time (2400 through 0700).

Contractor shall contact the WPF District Engineer or Planner to coordinate all site visits.

The CRRA reserves the right to change, modify or add to any supplied drawing as deemed necessary.

2.2 Fabrication

Contractor is responsible for constructing all materials for fabrication of primary trommel takeaway conveyors CV-123 and CV-223 in accordance with all applicable codes, standards, regulations and applicable laws, including:

- American Iron and Steel Institute (AISI).
- American National Standards institute (ANSI)
- American Society of Mechanical Engineers (ASME)
- American Welding Society (AWS)
- American Society for Testing And Material (ASTM)
- (NFPA)

- (OSHA)
- City of Hartford Codes and regulations.
- All other applicable codes and regulations.

Contractor shall monitor the quality of incoming material, employee workmanship, and site conditions. Any workmanship or materials identified by CRRA or the District to be deficient shall be immediately removed and/or corrected.

Contractor shall fabricate the primary trommel takeaway conveyors replacement parts for CV-123 and CV-223 as per the drawings listed in **Exhibit B** and the materials listed in Table 1.

Contractor shall deliver the fabricated primary trammel takeaway conveyors replacement parts for CV-123 and CV-223 to the WPF located at 300 Maxim Road, Hartford, Connecticut. Contractor must coordinate with District and CRRA on the exact date of delivery and the delivery location at the WPF. Ownership of the replacement parts shall remain with the Contractor until the replacement parts have been received by the District and CRRA at the WPF.

2.3 Installation

The Contractor shall decide on the method of removal and replacement of CV-123 and CV-223. The Contractor's method of replacement will need approval from the District prior to work being performed. Contractor will replace of all rotating components of CV-123 and CV-223; this includes all trough supply idlers, tail and head shaft assemblies, replacement of up-turn wheels and bend pulley assembly. The Contractor will replace of all non-rotating components of CV-123 and CV-223; this includes removal and re-installation of all sidewalls along with new side skirting systems and replacement of top deck steel. New sidewalls and top deck steel are to be fabricated and painted by contractor. The Contractor will install new belts on both CV-123 and CV-223. Both CV-123 and CV-223 belt splices shall be hot vulcanized.

The removal and replacement of CV-123 and CV-223 shall be scheduled for over a weekend. The WPF conveyor lines will be shut down and will not operate during the removal and replacement of CV-123 and CV-223.

The Contractor shall be responsible for the proper disposal of any and all parts removed from CV-123 and CV-223. Contractor shall inform the District and CRRA of its intended method and place of disposal.

3. WORK TO BE PERFORMED

- (a) Contractor shall install material and components for the CV-123 and CV-223 as per the drawings listed in **Exhibit B** and the materials listed in **Table 1**.
- (b) Contractor shall agree that all areas around CV-123 and CV-223 that are removed by

Contractor shall be reinstalled upon completion of the project.

- (c) Contractor shall not proceed with the installation until materials are delivered to the site; any pre-assembly that is required shall be done prior to commencing the work.

4. WORK BY OTHERS

The District will connect all safety and bearing protection devices. CRRA or the District will assist Contractor with the project to insure it is executed in accordance with the schedule agreed upon.

5. DRAWINGS

Contractor will be supplied with drawings showing the general structure of CV-123 and CV-223. The drawings are listed in **Exhibit B** to the Agreement. The drawings may not have all dimensions that are required for fabrication. Therefore these drawing are for reference only; exact dimensions will be required to be field measured by the Contractor.

6. ENGINEERING REQUIREMENTS

6.1 General Performance Conditions

Any equipment or materials supplied by Contractor shall be the product of a manufacturer experienced in the design, fabrication and installation of equipment for the purpose required.

6.2 Installation

6.2.1 Method Of Replacement

Contractor shall propose a method of removal/replacement of the CV-123 and CV-223 parts along with a schedule and review the proposals with the CRRA and District Engineers. Contractor shall supply all tools, welding supplies and rigging equipment as required to complete the work. Should Contractor require any conduits and/or sprinkler piping removed, a request must be submitted to CRRA or the District five (5) days prior to commencement of the work. All process equipment, piping, building structure or conduit damaged during this work must be repaired to a pre-existing condition. Any bracing, pipe, guarding or other obstructions that the contractor may require removal in order to removed/installed the conveyor sidewalls will be performed by the Contractor. During the removal/installation of the work, if an unforeseen problem occurs, or the project will not be completed within the allocated time, CRRA and the District Engineers shall be notified immediately by contractor. CRRA and the District Engineers must approve any downtime occurring due to overage on installation time.

7. CHECKOUT, STARTUP AND INITIAL OPERATIONS

7.1 General

Contractor shall render all services and perform all work required to refurbish conveyors CV-123 and CV-223.

7.2 Operational Control and System Turnover

Prior to start up, Contractor shall review the work with CRRA and the District Engineers to insure that the CV-123 and CV-223 and other affected equipment are prepared for start-up and all personnel, tools, fabrication material and other items that may affect operation have been removed from the area.

8. COMPLETION SCHEDULE

Contractor shall comply with the schedule in Exhibit C of the Agreement.

9. WARRANTY

Contractor shall warrant the labor and material supplied for a period of **one year** after CRRA accepts the project completion.

10. PRE-CONSTRUCTION CONFERENCE

Prior to commencement of work, a pre-construction conference will be held with the representatives of Contractor, CRRA and the District. During this meeting, scheduling, method of replacement, on site storage areas, and safety procedures at the plant will be discussed. A date for the pre-construction conference will be decided after award of the work.

11. MATERIALS

Contractor shall supply all fabrication material. Contractor-required materials are listed in the following table.

TABLE 1: Materials

Item	Description	Quantity
Sidewall Set	See Attached Drawing	1 per conveyor
Tail Shaft	See Attached Drawing	1 per conveyor
Tail shaft bearing housings	3 7/16" SKF-SAF 520	2 per conveyor
Tail shaft bearings	SKF- SF 22220	2 per conveyor
Tail shaft bearing taper lock	SKF- SNW 20	2 per conveyor

Tail shaft bearing locking ring	SKF- SE 20-17	2 per conveyor
Tail shaft bearing seal	SKF- LER 102	4 per conveyor
Tail shaft take-up assembly	Dodge- HD350X36TUFR	2 per conveyor
Up-turn wheels bearing housing	SKF-SAF 517	4 per conveyor
Up-turn wheels bearing	SKF-SF 22217	4 per conveyor
Up-turn wheels taper lock	SKF- SNW 17	4 per conveyor
Up-turn wheels locking ring	SKF- SR 15-0	4 per conveyor
Up-turn wheels bearing seal	SKF- LOR 37	8 per conveyor
Up-turn wheels	See Attached Drawing	2 per conveyor
Side skirt brackets	ARCH MHF 2001-ST	35 per conveyor
Side skirting rubber	8" x 1/2" x 150 feet	1 per conveyor
Tail pulley with 1" herringbone lagging	16 X 51 K40 3 15/16"	1 per conveyor
Taper lock for pulley	4545 3 15/16"	2 per conveyor
Feed idlers (20 degrees)	D3601S-48	25 per conveyor
Feed idlers (adjustable)	D3606S-48	4 per conveyor
Nuts and bolts	Grade 8	As required
Belt	Goodyear 4 ply belt (500 PIW), 48" wide, 160' long with 1/4" top cover and 1/16" bottom cover. Grade II	1 per conveyor
Head shaft bearing housings	3 7/16" SKF-SAF 520	2 per conveyor
Head shaft bearings	SKF- SF 22220	2 per conveyor
Head shaft bearing taper lock	SKF- SNW 20	2 per conveyor
Head shaft bearing locking ring	SKF- SE 20-17	2 per conveyor
Head shaft bearing seal	SKF- LER 102	4 per conveyor
Head pulley with 1/2" herringbone V-lagging (mild steel)	18 X 51 K45 4 7/16"	1 per conveyor
Head taper lock for pulley	TL4545 3 15/16"	2 per conveyor
Bent pulley - flat mild steel	Dodge 16" X 51" Flat Drum Mild Steel	1 per conveyor

Bent pulley – bearings	SKF- SAF 515 2 7/16"	2 per conveyer
Bent pulley – taper lock	TL Hubs K35 TL3535 X 2 15/16"	2 per conveyer
Return Idlers	To be supplied by MDC – Installed by Contractor	As required
Idlers, 20 degree feed idlers (impact)	D3604S-48	8 per conveyer
Miscellaneous steel (decking repairs)	A36 Steel	As required
Upturn wheel hub and taper lock	K25- Hub & TL 2525	2 per conveyer

Contractor is responsible for all dimensions, quantities and performance requirements to be confirmed and correlated at the job site; for all information that pertains to techniques of construction; and for all coordination of the work of all trades; and for assuring consistency with the specification documents.

12. WORKING ON SITE

Work areas shall be clean at the end of each working day. Material stored on site will be stored in a designated location as specified by the District. Contractor will be responsible for reviewing and upholding **all required safety protocols** set forth by the District while working on site.

13. SAFETY ON SITE

In order to protect the safety and health of the contractors employees under this contract, the Contractor will comply with all pertinent provisions of the department of labor, occupational safety and health administration (OSHA), chapter XVII parts 1910 and parts 1926 and the latest revisions and amendments. The District maintenance supervisor will hold a safety meeting with all contractor personnel prior to initiating any work.

The Contractor shall abide by the plant lock out / tag out program which forbids, at any time, performing any type of work for any period of time by any one, before implementing lockout/ tag out procedures and formally surrendering the equipment to the Contractor. Each person shall apply his own lock to the equipment that has been de-energized and locked by the District staff to perform the work under this contract. These locks shall be easily identified as the contractor's lockout locks.

14. USE OF UTILITIES AND SANITARY FACILITIES

The District shall provide adequate sanitary facilities for the Contractor's employees working at the job site. The Contractor shall maintain the sanitary facilities in a clean, satisfactory and sanitary condition at all times. Failure to comply with these requirements will result in the Contractor being required to provide his own sanitary facility. As part of this work may be done in cold weather, the Contractor shall be responsible for providing workers with an enclosed warming area to review plans and for break purposes.

The District shall supply a source of electrical power to operate power equipment and power to supplement lighting. This source shall be 115 volt, 60 Hz A.C, 20 Amp or 460 volt 60 Hz A.C electrical power necessary for the proper completion of the work and during its entire progress at no cost to the Contractor. The Contractor will be required to provide all extension cords, accessories and appurtenances for the distribution of electrical energy to the work areas. Any additional lighting needed will be supplied by the Contractor. The Contractor will be responsible for clean up and removal of the temporary distribution system.

The District shall provide all necessary water for wetting down the area for fire control. The Contractor shall provide and maintain, at his own expense, all such appurtenances and accessories necessary for the distribution of water to and within the work areas, and will be responsible for the removal and cleanup of the temporary distribution system at the completion of the work.

EXHIBIT B

To

**REFURBISHMENT OF BELT CONVEYORS CV-123/223
AT THE
MID-CONNECTICUT WASTE PROCESSING FACILITY
AGREEMENT**

DRAWINGS

EXHIBIT B
DRAWINGS

The following drawings are hereby incorporated by reference and made a part of this Agreement as if such plans had been attached in their entirety to this Agreement:

DRAWING NUMBER	DRAWING DESCRIPTION
DRAWING #1	Assembly Skirtboard - CV-123/223.
DRAWING #2	Hopper Guard CV-123
DRAWING #3	CV-123/223 Head Shaft
DRAWING #4	CV-123/223 Tail Shaft
DRAWING #5	CV123/223 Conveyor Panels Page 1
DRAWING #6	CV123/223 Conveyor Panels Page 2
DRAWING #7	CV123/223 General Arrangement Page 1
DRAWING #8	CV123/223 General Arrangement Page 2
DRAWING #9	CV123/223 General Arrangement Page 3
DRAWING #10	CV123/223 General Arrangement Page 4
DRAWING #11	CV123/223 Wall Clips
DRAWING #12	CV123/223 Idler
PPG -HPC/Industrial Semi Gloss Oil	7-844 Series Paint (Color: Snicerdoodle)

12/3/22

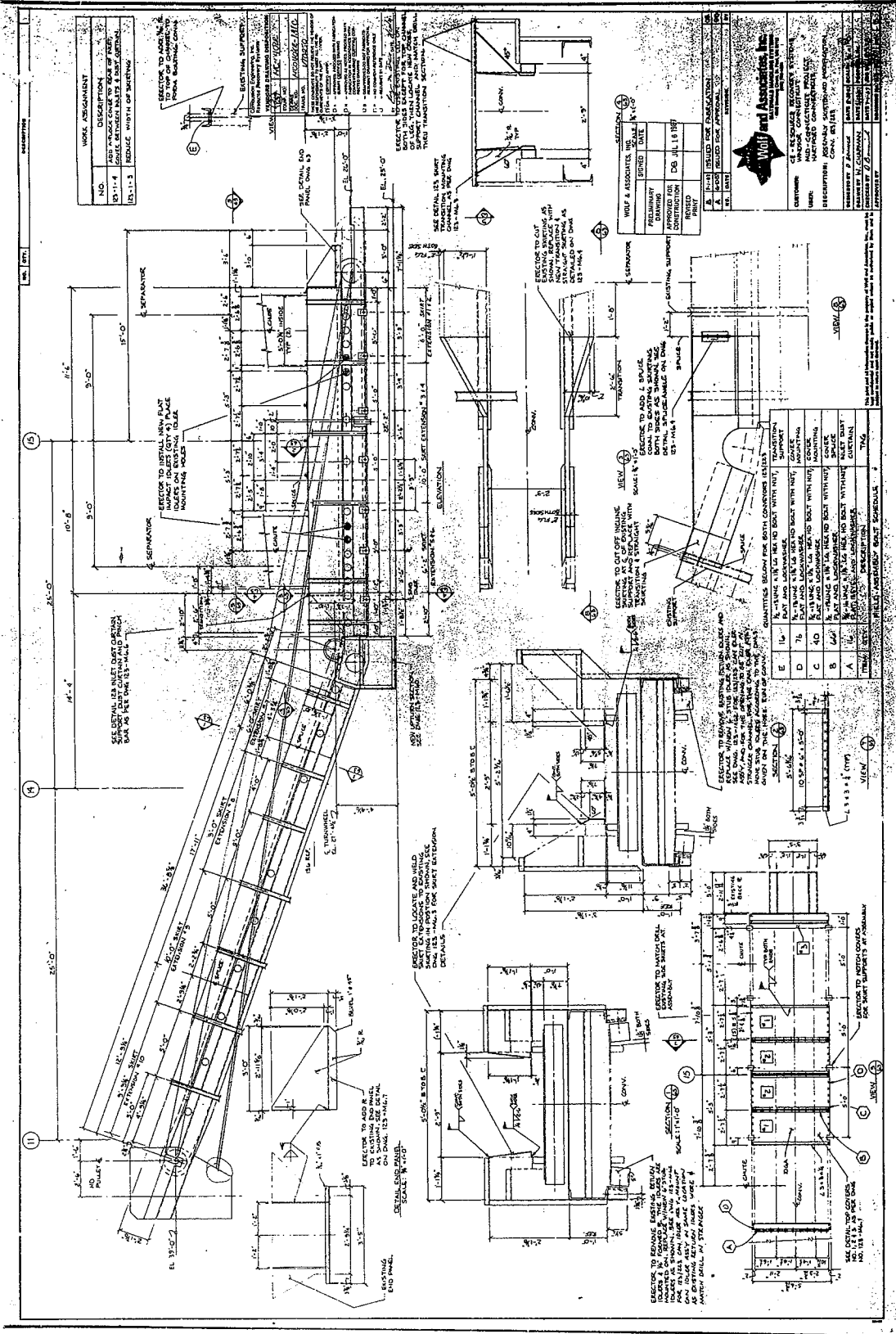

NO.	REVISION	DATE	BY	CHKD.
1	ISSUE FOR PERMIT	12/15/22	JW	ML
2	REVISIONS TO PERMIT	12/15/22	JW	ML
3	REVISIONS TO PERMIT	12/15/22	JW	ML
4	REVISIONS TO PERMIT	12/15/22	JW	ML
5	REVISIONS TO PERMIT	12/15/22	JW	ML
6	REVISIONS TO PERMIT	12/15/22	JW	ML
7	REVISIONS TO PERMIT	12/15/22	JW	ML
8	REVISIONS TO PERMIT	12/15/22	JW	ML
9	REVISIONS TO PERMIT	12/15/22	JW	ML
10	REVISIONS TO PERMIT	12/15/22	JW	ML
11	REVISIONS TO PERMIT	12/15/22	JW	ML
12	REVISIONS TO PERMIT	12/15/22	JW	ML
13	REVISIONS TO PERMIT	12/15/22	JW	ML
14	REVISIONS TO PERMIT	12/15/22	JW	ML
15	REVISIONS TO PERMIT	12/15/22	JW	ML
16	REVISIONS TO PERMIT	12/15/22	JW	ML
17	REVISIONS TO PERMIT	12/15/22	JW	ML
18	REVISIONS TO PERMIT	12/15/22	JW	ML
19	REVISIONS TO PERMIT	12/15/22	JW	ML
20	REVISIONS TO PERMIT	12/15/22	JW	ML
21	REVISIONS TO PERMIT	12/15/22	JW	ML
22	REVISIONS TO PERMIT	12/15/22	JW	ML
23	REVISIONS TO PERMIT	12/15/22	JW	ML
24	REVISIONS TO PERMIT	12/15/22	JW	ML
25	REVISIONS TO PERMIT	12/15/22	JW	ML
26	REVISIONS TO PERMIT	12/15/22	JW	ML
27	REVISIONS TO PERMIT	12/15/22	JW	ML
28	REVISIONS TO PERMIT	12/15/22	JW	ML
29	REVISIONS TO PERMIT	12/15/22	JW	ML
30	REVISIONS TO PERMIT	12/15/22	JW	ML
31	REVISIONS TO PERMIT	12/15/22	JW	ML
32	REVISIONS TO PERMIT	12/15/22	JW	ML
33	REVISIONS TO PERMIT	12/15/22	JW	ML
34	REVISIONS TO PERMIT	12/15/22	JW	ML
35	REVISIONS TO PERMIT	12/15/22	JW	ML
36	REVISIONS TO PERMIT	12/15/22	JW	ML
37	REVISIONS TO PERMIT	12/15/22	JW	ML
38	REVISIONS TO PERMIT	12/15/22	JW	ML
39	REVISIONS TO PERMIT	12/15/22	JW	ML
40	REVISIONS TO PERMIT	12/15/22	JW	ML
41	REVISIONS TO PERMIT	12/15/22	JW	ML
42	REVISIONS TO PERMIT	12/15/22	JW	ML
43	REVISIONS TO PERMIT	12/15/22	JW	ML
44	REVISIONS TO PERMIT	12/15/22	JW	ML
45	REVISIONS TO PERMIT	12/15/22	JW	ML
46	REVISIONS TO PERMIT	12/15/22	JW	ML
47	REVISIONS TO PERMIT	12/15/22	JW	ML
48	REVISIONS TO PERMIT	12/15/22	JW	ML
49	REVISIONS TO PERMIT	12/15/22	JW	ML
50	REVISIONS TO PERMIT	12/15/22	JW	ML
51	REVISIONS TO PERMIT	12/15/22	JW	ML
52	REVISIONS TO PERMIT	12/15/22	JW	ML
53	REVISIONS TO PERMIT	12/15/22	JW	ML
54	REVISIONS TO PERMIT	12/15/22	JW	ML
55	REVISIONS TO PERMIT	12/15/22	JW	ML
56	REVISIONS TO PERMIT	12/15/22	JW	ML
57	REVISIONS TO PERMIT	12/15/22	JW	ML
58	REVISIONS TO PERMIT	12/15/22	JW	ML
59	REVISIONS TO PERMIT	12/15/22	JW	ML
60	REVISIONS TO PERMIT	12/15/22	JW	ML
61	REVISIONS TO PERMIT	12/15/22	JW	ML
62	REVISIONS TO PERMIT	12/15/22	JW	ML
63	REVISIONS TO PERMIT	12/15/22	JW	ML
64	REVISIONS TO PERMIT	12/15/22	JW	ML
65	REVISIONS TO PERMIT	12/15/22	JW	ML
66	REVISIONS TO PERMIT	12/15/22	JW	ML
67	REVISIONS TO PERMIT	12/15/22	JW	ML
68	REVISIONS TO PERMIT	12/15/22	JW	ML
69	REVISIONS TO PERMIT	12/15/22	JW	ML
70	REVISIONS TO PERMIT	12/15/22	JW	ML
71	REVISIONS TO PERMIT	12/15/22	JW	ML
72	REVISIONS TO PERMIT	12/15/22	JW	ML
73	REVISIONS TO PERMIT	12/15/22	JW	ML
74	REVISIONS TO PERMIT	12/15/22	JW	ML
75	REVISIONS TO PERMIT	12/15/22	JW	ML
76	REVISIONS TO PERMIT	12/15/22	JW	ML
77	REVISIONS TO PERMIT	12/15/22	JW	ML
78	REVISIONS TO PERMIT	12/15/22	JW	ML
79	REVISIONS TO PERMIT	12/15/22	JW	ML
80	REVISIONS TO PERMIT	12/15/22	JW	ML
81	REVISIONS TO PERMIT	12/15/22	JW	ML
82	REVISIONS TO PERMIT	12/15/22	JW	ML
83	REVISIONS TO PERMIT	12/15/22	JW	ML
84	REVISIONS TO PERMIT	12/15/22	JW	ML
85	REVISIONS TO PERMIT	12/15/22	JW	ML
86	REVISIONS TO PERMIT	12/15/22	JW	ML
87	REVISIONS TO PERMIT	12/15/22	JW	ML
88	REVISIONS TO PERMIT	12/15/22	JW	ML
89	REVISIONS TO PERMIT	12/15/22	JW	ML
90	REVISIONS TO PERMIT	12/15/22	JW	ML
91	REVISIONS TO PERMIT	12/15/22	JW	ML
92	REVISIONS TO PERMIT	12/15/22	JW	ML
93	REVISIONS TO PERMIT	12/15/22	JW	ML
94	REVISIONS TO PERMIT	12/15/22	JW	ML
95	REVISIONS TO PERMIT	12/15/22	JW	ML
96	REVISIONS TO PERMIT	12/15/22	JW	ML
97	REVISIONS TO PERMIT	12/15/22	JW	ML
98	REVISIONS TO PERMIT	12/15/22	JW	ML
99	REVISIONS TO PERMIT	12/15/22	JW	ML
100	REVISIONS TO PERMIT	12/15/22	JW	ML

WELF & ASSOCIATES, INC.
 ARCHITECTS
 1000 W. 10th Street, Suite 100
 Oklahoma City, Oklahoma 73106
 Phone: (405) 521-1111
 Fax: (405) 521-1112
 www.welf.com

PROJECT INFORMATION

PROJECT NO.	123456
PROJECT NAME	METROPOLITAN DISTRICT MID CONN PROJECT
CLIENT	Metropolitan District
DATE	12/15/22

DESIGNER
 WELF & ASSOCIATES, INC.
 ARCHITECTS

DATE
 12/15/22

SCALE
 AS SHOWN

PROJECT NO.
 123456

PROJECT NAME
 METROPOLITAN DISTRICT MID CONN PROJECT

CLIENT
 Metropolitan District

DATE
 12/15/22

METROPOLITAN DISTRICT MID CONN PROJECT

Drawing #2

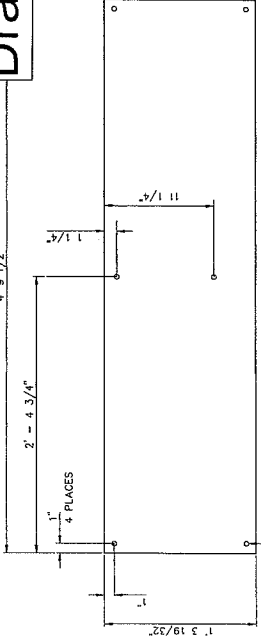

PLAN VIEW - 3/8" PLATE
SCALE: 1 1/2" = 1' - 0"

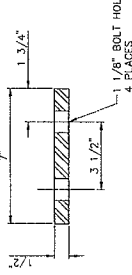

SECTION C-C
SCALE: 3" = 1' - 0"

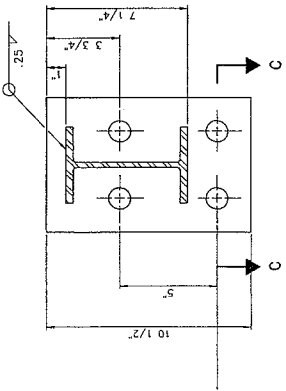

SECTION B-B
SCALE: 3" = 1' - 0"

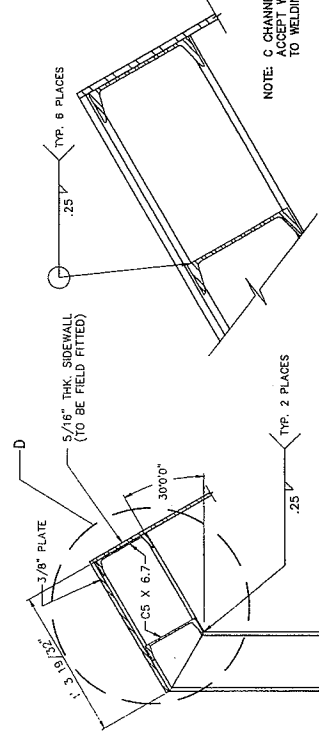

VIEW D
SCALE: 3" = 1' - 0"

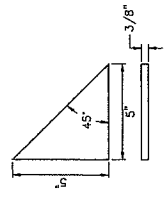

GUSSET PLATE
SCALE: 3" = 1' - 0"

NOTE: C CHANNEL TO BE CUT TO ACCEPT W CHANNEL PRIOR TO WELDING IN PLACE.

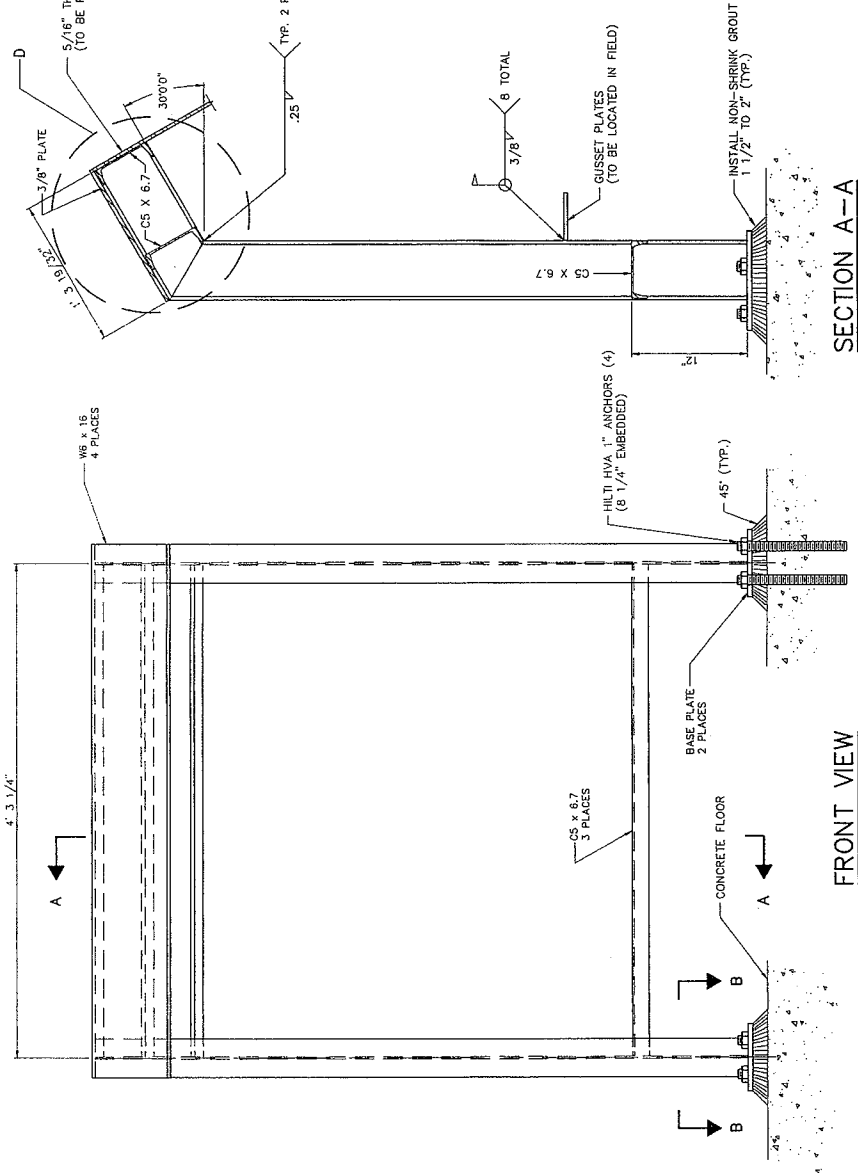

FRONT VIEW
SCALE: 1 1/2" = 1' - 0"

SECTION A-A
SCALE: 1 1/2" = 1' - 0"

	THE METROPOLITAN DISTRICT MID-CONNECTICUT PROJECT HARTFORD, CONNECTICUT
	CONNECTICUT RESOURCE RECOVERY AUTHORITY
GUARD FOR 123 HOPPER SCALE AS INDICATED	
DRAWN T.J.S. SUBMITTED	ENGINEER M.D.Z. DATE SEPT. 9, 1991 SERIAL NO.

Drawing #3

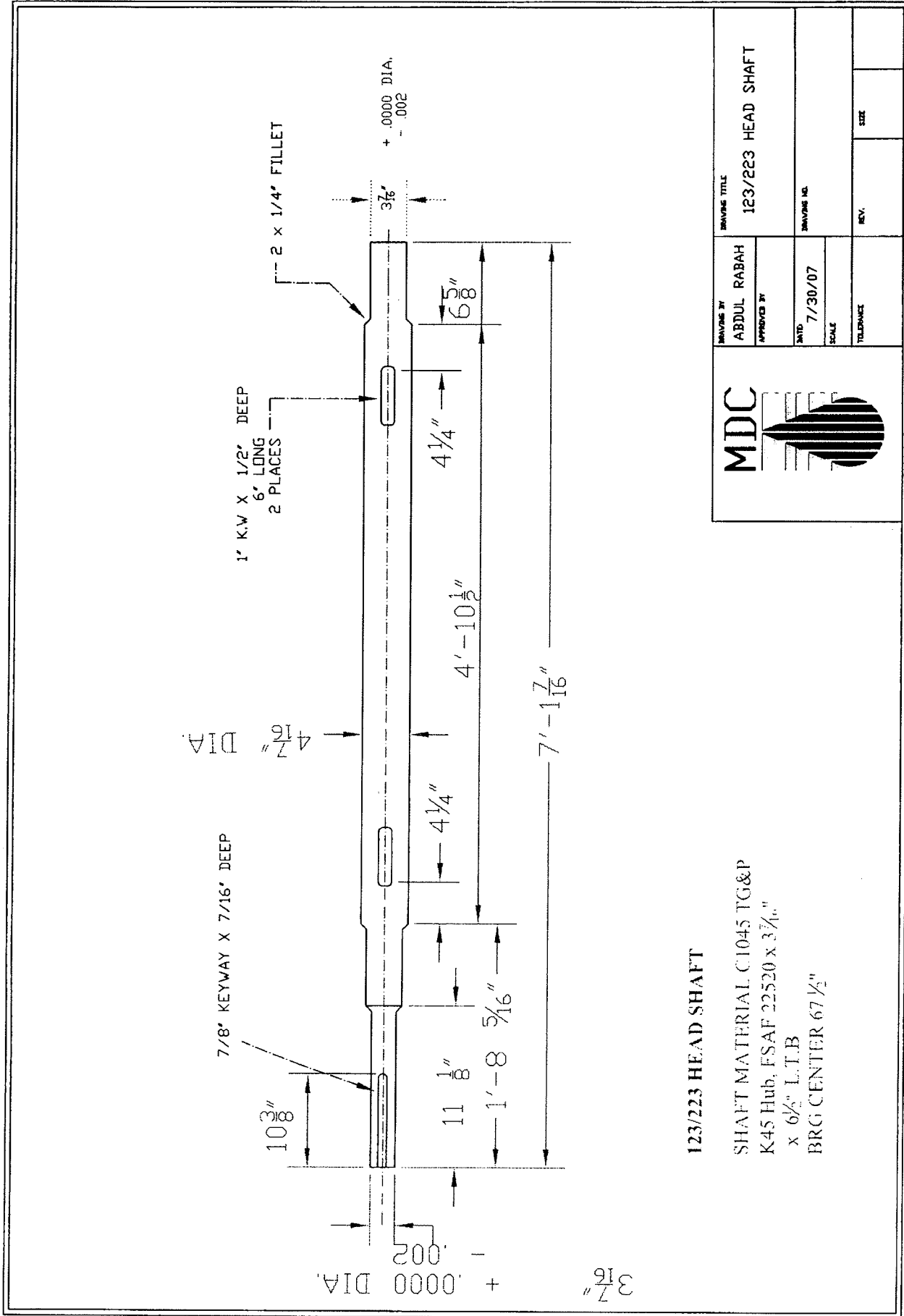

Drawing #4

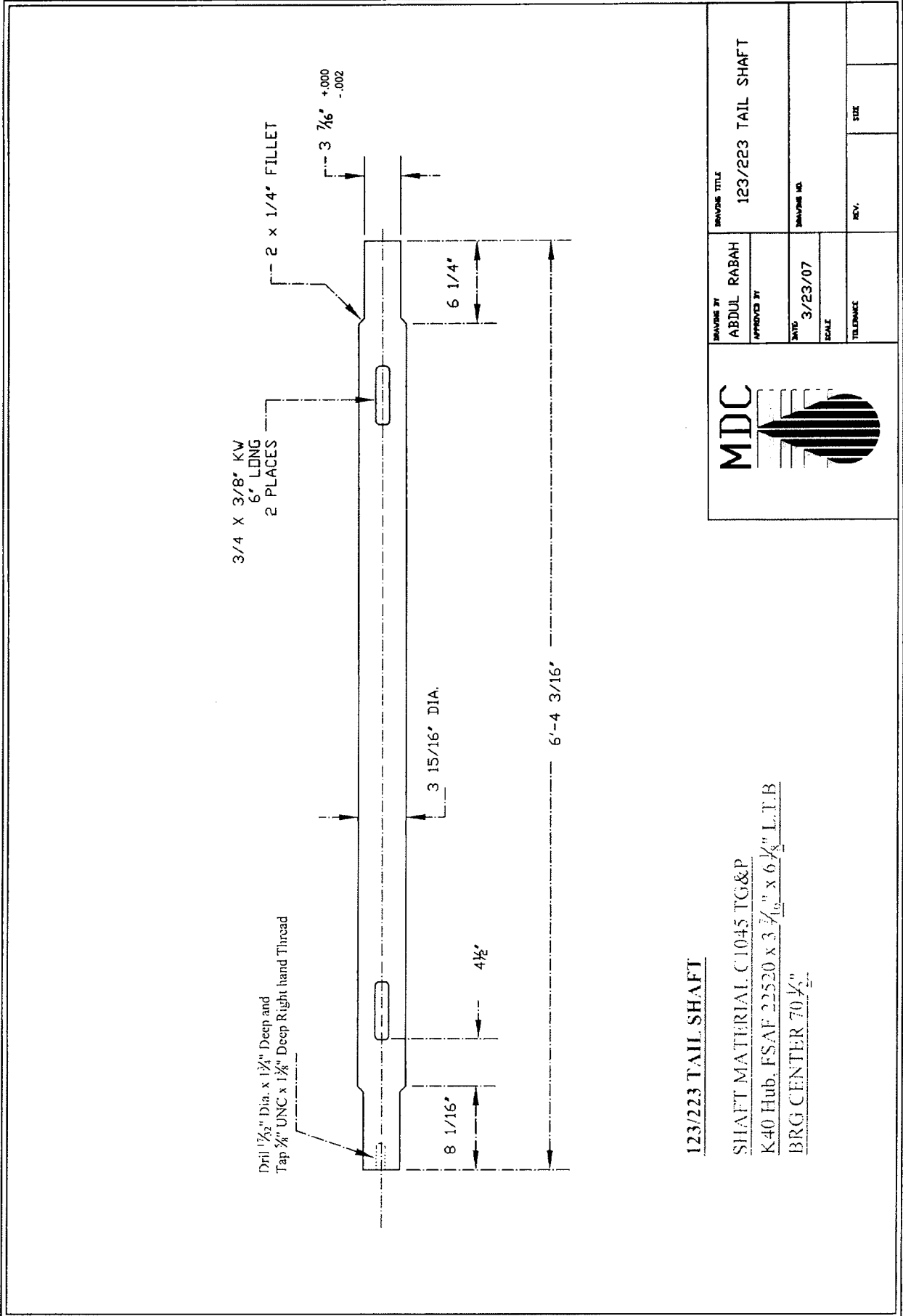

123/223 TAIL SHAFT

SHAFT MATERIAL C1045 TG&P

K40 Hub. FSAF 22520 x 3 7/16" x 6 1/8" L.T.B

BRG CENTER 70 1/2"

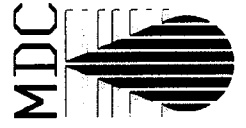
	DRAWING BY ABDUL RABAH	DRAWING TITLE 123/223 TAIL SHAFT
	APPROVED BY	DRAWING NO.
DATE 3/23/07	SCALE	REV.
TOLERANCE	SIZE	SIZE

Drawing #5

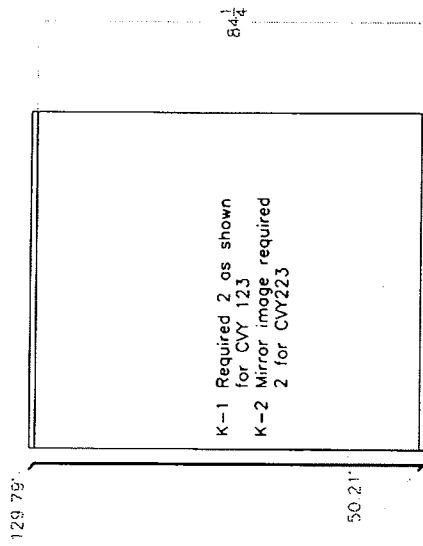

50 1/2"

2 1/8"

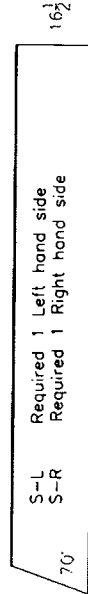

120"

16 1/2"

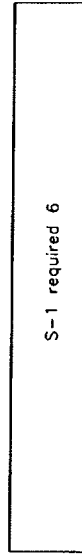

120"

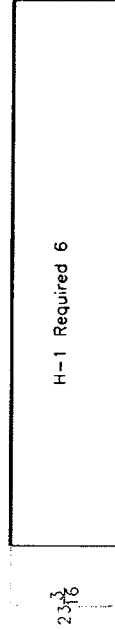
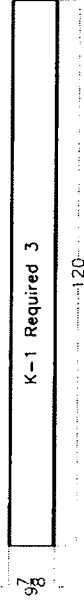

<p>TOLERANCES DECIMALS FRACTIONS ± 0-15' ANGLES ± 0-15' TIME .005</p>	<p>DRAWN BY</p>	<p>DRAWING TITLE</p>
	<p>APPROVED BY</p>	<p>CVY Panels 2</p>
	<p>DATE</p>	<p>CUSTOMER</p>
	<p>SCALE</p>	
	<p>WORK ORDER</p>	<p>SIZE DWG</p>
	<p>D</p>	<p>CP 123-223-2</p>
		<p>REV.</p>

Drawing #6

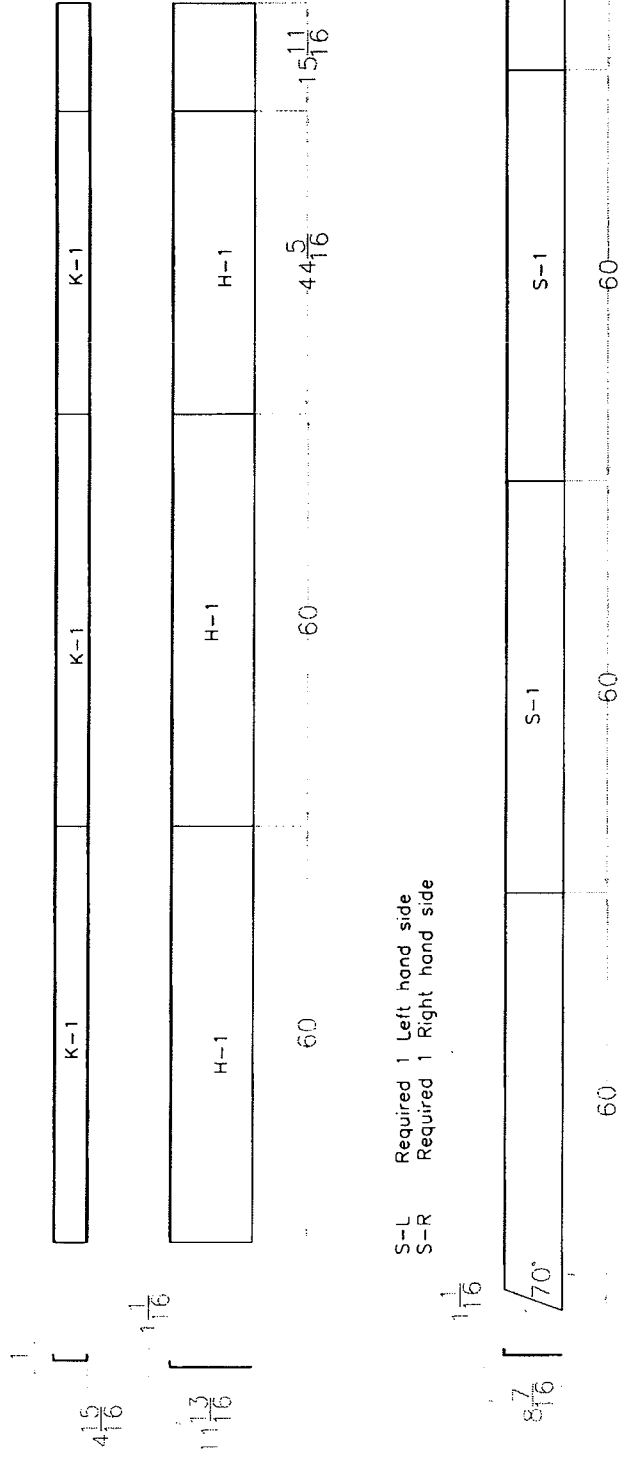

S-L Required 1 Left hand side
 S-R Required 1 Right hand side

Drawing #7

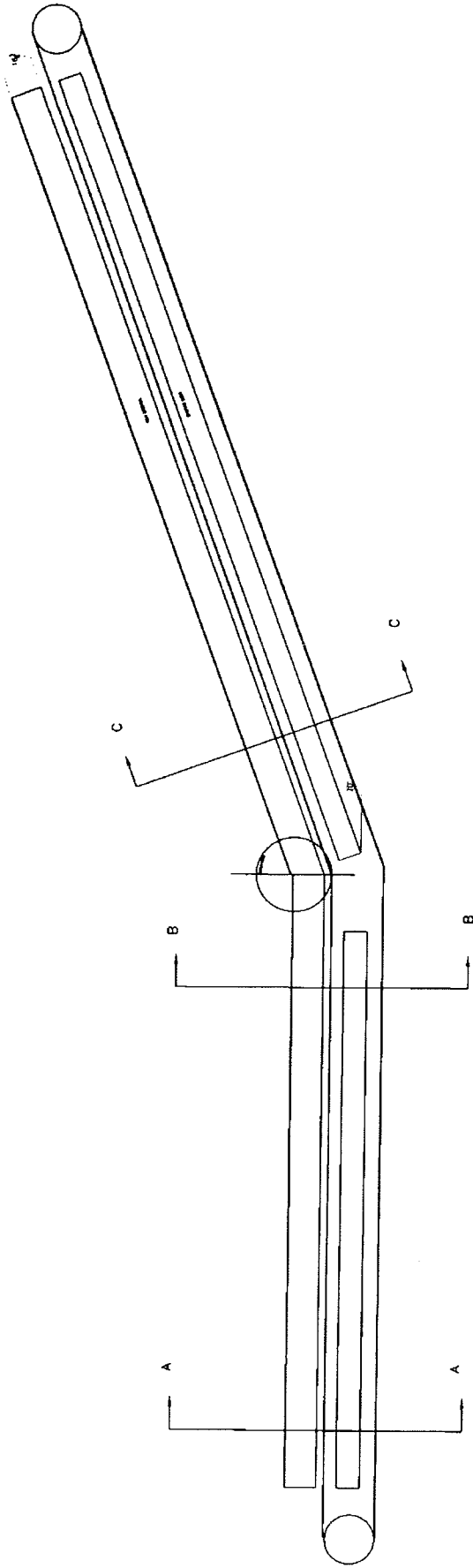

General Arrangement	1
Sheet No.	D
Date	12-22-1
Scale	
Author	
Checker	
Appr.	

Drawing #8

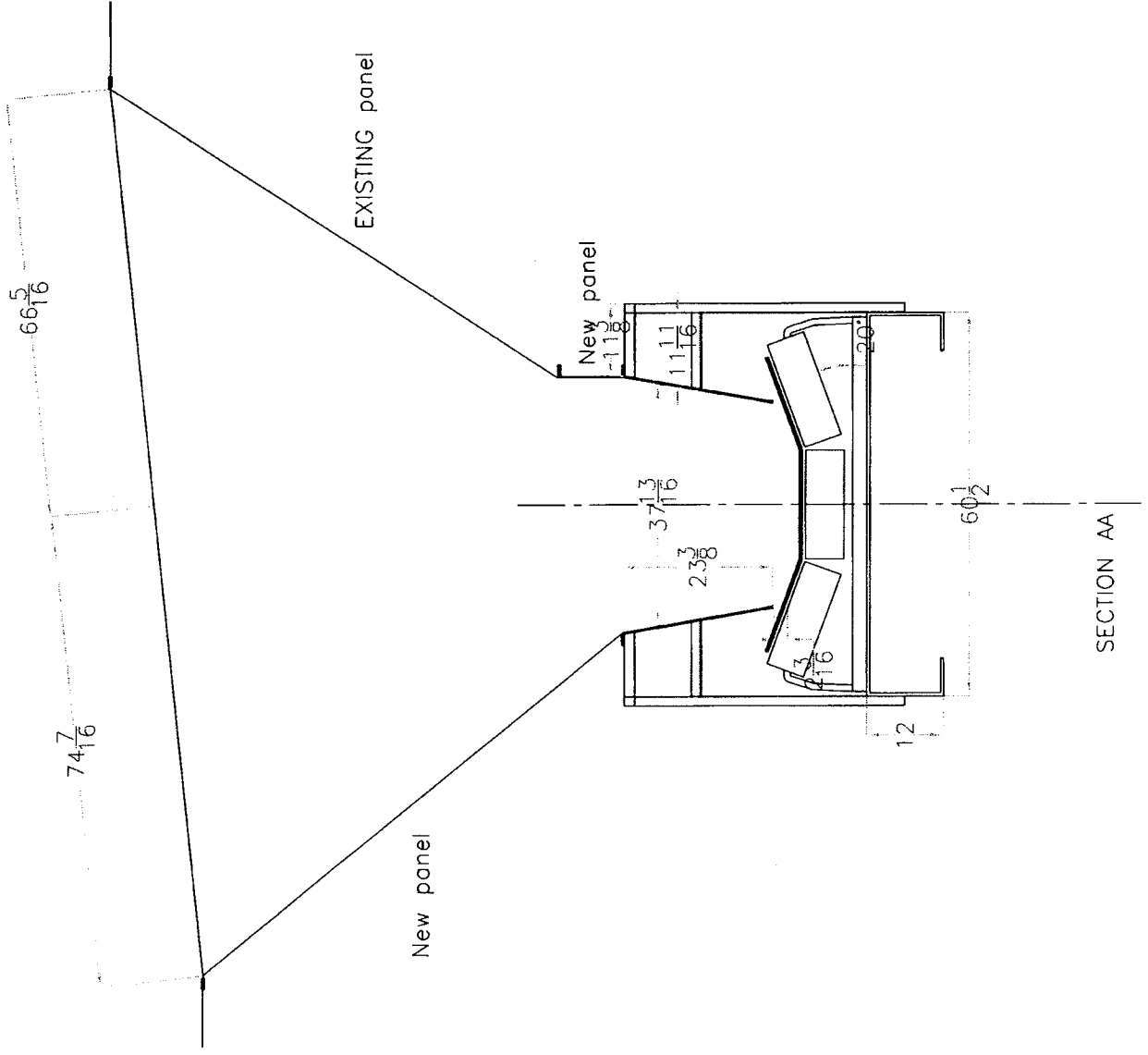

Drawing #9

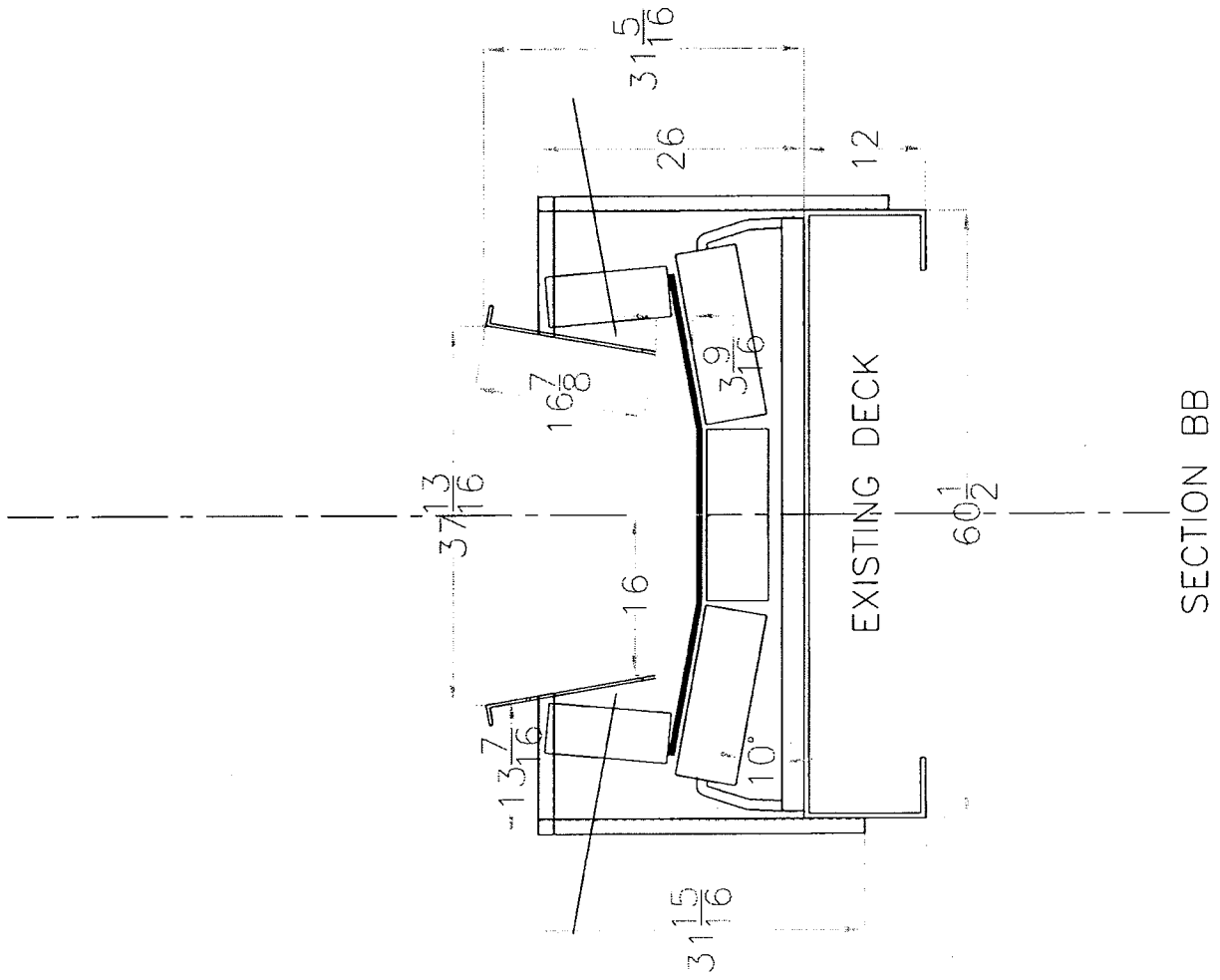

Drawing #10

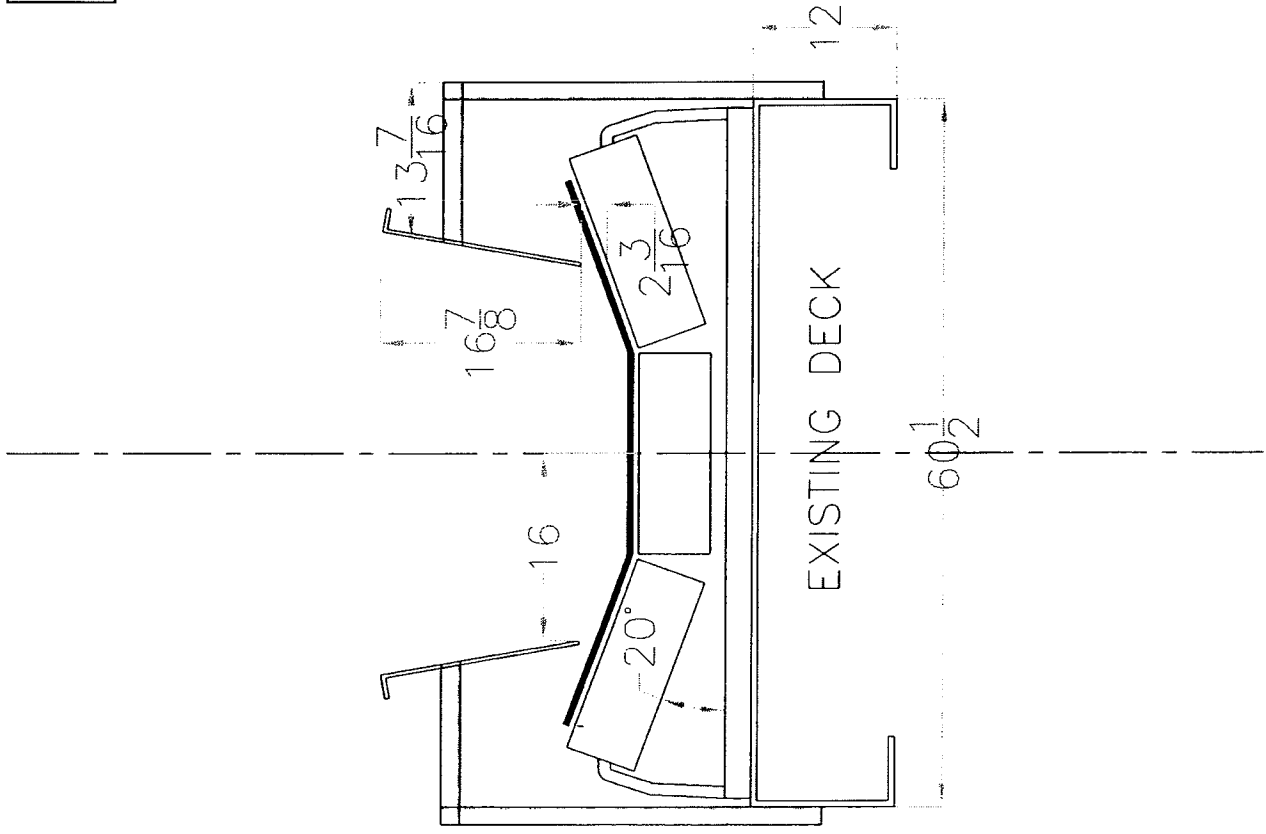

SECTION CC

Drawing #11

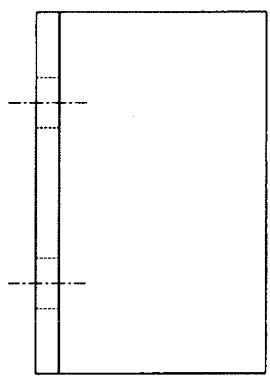
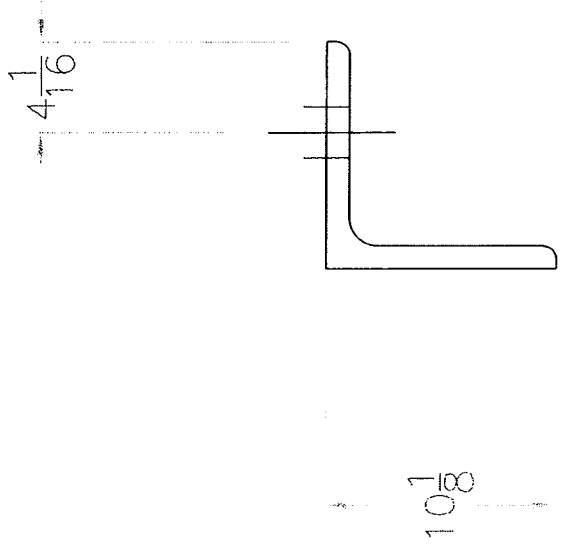
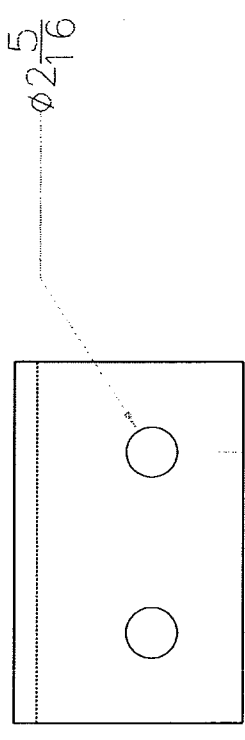

Required 50 pieces

Drawing #12

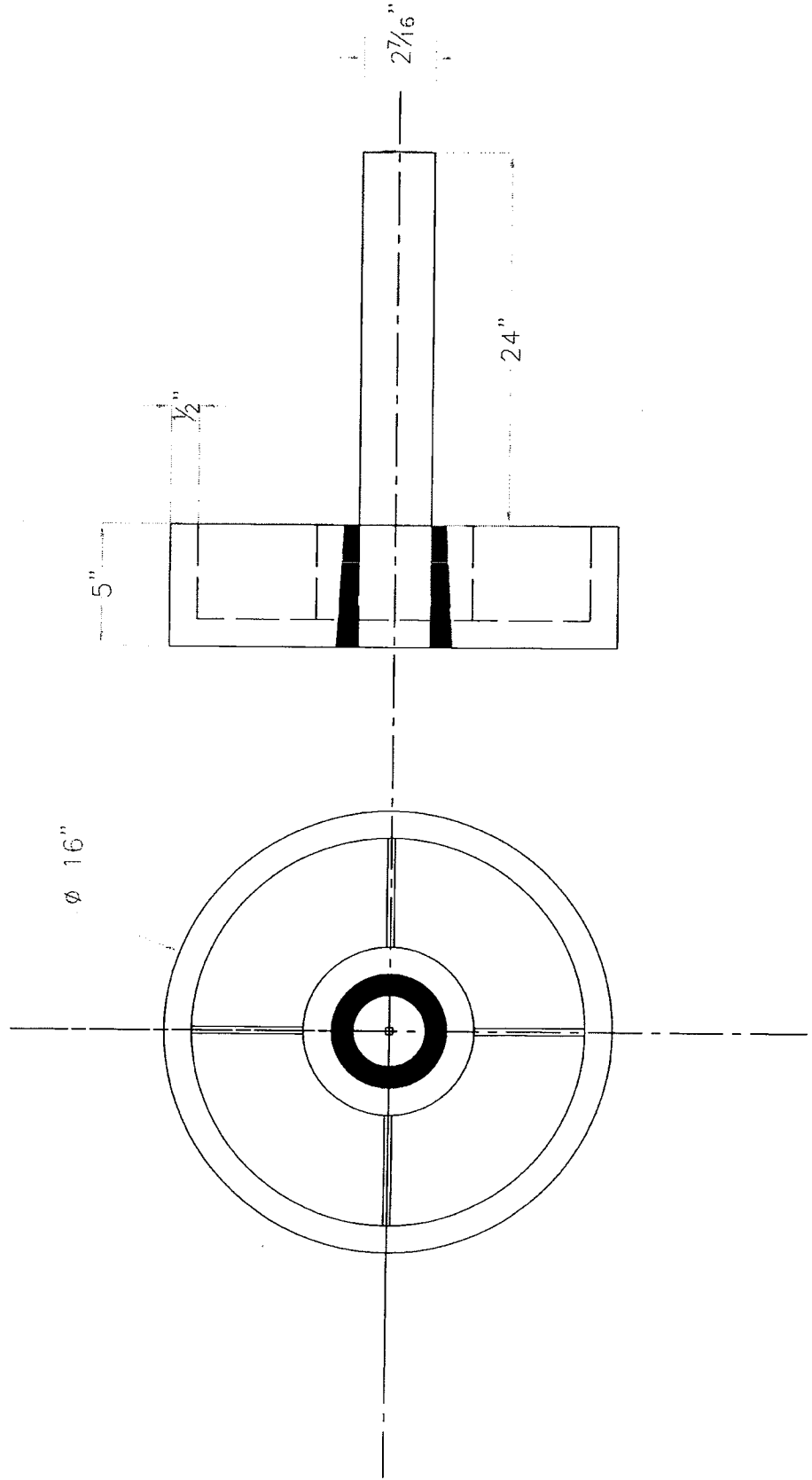



HPC/Industrial Maintenance

Int. Industrial Semi-Gloss Oil

Generic Type

Alkyd/Oil Resin

General Description

Industrial Enamels are for industrial use and may be used on properly prepared and properly primed interior surfaces of wood, metal, masonry, plaster, and composition board. For Professional Use Only; Not Intended for Household Use.

Tinting and Base Information

Use PITTSBURGH® Paints Custom Colorants and refer to THE VOICE OF COLOR formula book for tinting instructions.

7-844	White and Pastel Mixing Base
7-845	Midtone Mixing Base
7-846	Deeptone Mixing Base

Color: Snicerdoodle

Recommended Uses

- Aluminum
- Drywall
- Ferrous Metal
- Galvanized Steel
- Wood
- Concrete, Stucco, Plaster, Masonry
- CMU

Features / Benefits

- Full color tinting capability
- Durable interior semi-gloss finish
- Performance Offset to Federal Standards TT-E-508, TT-E-509
- MPI category #81, Quick Dry Enamel Semi-Gloss

Limitations of Use

Apply when air and surface temperatures are above 50°F (10°C) and surface temperature is at least 5°F (3°C) above dew point. Not recommended for use on floors. For Professional Use Only; Not Intended for Household Use. IMPORTANT: All oil based alkyd products change color with age. The yellow discoloration is most visible in whites and light colors. PITTSBURGH® Paints latex products are recommended when yellowing is a concern. Drying times listed may vary depending on temperature, humidity and air movement. DANGER: Rags, steel wool or waste soaked with this product may spontaneously catch fire if improperly discarded. Immediately after use, place rags, steel wool or waste in a sealed water-filled metal container. Refer to www.pittsburghpaints.com. Spontaneous Combustion Advisory for additional information.

Product Data

Gloss:	Semi-Gloss: 50 to 70 (60°Gloss Meter)
VOC*:	2.80 lbs/gal 336.00 g/L
Coverage:	400 to 450 sq ft/gal (37 to 41 sq. m/3.78L)
<i>Note: Does not include loss due to varying application method, surface porosity, or mixing.</i>	
DFT:	2.0 minimum to 2.2 maximum
Weight/Gallon*:	11.7 lbs. (5.3 kg) +/- 0.2 lbs. (91 g)
Volume Solids*:	56% +/- 2%
Weight Solids*:	76% +/- 2%
Clean-up:	Paint Thinner

Results will vary by color, thinning and other additives.
*Product data calculated on 7-844

Drying Time:

To Touch:	3 to 5 hours
To Handle:	6 to 8 hours
To Recoat:	24 hours
Dry Time @77°F (25°C); 50% relative humidity	

Flash Point: 120°F, (49°C)

HPC/Industrial Maintenance**Int. Industrial Semi-Gloss Oil****General Surface Preparation**

The surface to be coated must be dry, clean, and free from surface contaminants. All cracks and other surface imperfections must be repaired and spot-primed. Dull glossy surfaces by sanding. **WARNING!** If you scrape, sand, or remove old paint, you may release lead dust or fumes. **LEAD IS TOXIC. EXPOSURE TO LEAD DUST OR FUMES CAN CAUSE SERIOUS ILLNESS, SUCH AS BRAIN DAMAGE, ESPECIALLY IN CHILDREN. PREGNANT WOMEN SHOULD ALSO AVOID EXPOSURE.** Wear a properly fitted NIOSH-approved respirator and prevent skin contact to control lead exposure. Clean up carefully with a HEPA vacuum and a wet mop. Before you start, find out how to protect yourself and your family by contacting the USEPA National Lead Information Hotline at 1-800-424-LEAD or log on to www.epa.gov/lead. In Canada contact a regional Health Canada office. Follow these instructions to control exposure to other hazardous substances that may be released during surface preparation.

WOOD: Sand lightly in order to remove surface roughness and loose wood fibers. Then remove all dirt, dust, grime and any other forms of contamination. Remove grease and oils by Solvent Cleaning per SSPC-SP1.

FERROUS METAL: Rust and other surface contaminants must be removed. Then the surface thoroughly cleaned to remove all other contaminants.

GALVANIZED STEEL: Solvent Clean per SSPC-SP1 to remove grease and oils. If any oxidation (white rust) has formed, sand and remove all forms of contamination. If the galvanized has been passivated or stabilized, the surface must be abraded, i.e. Brush-Off Blast Clean per SSPC-SP7 or chemically treat the surface.

ALUMINUM: Solvent Clean per SSPC-SP1 to remove grease and oils.

CONCRETE, STUCCO, PLASTER, MASONRY other than CMU: Allow all concrete, mortar, plaster, etc. to cure for thirty (30) days under normal drying conditions. Remove all dirt, dust, grime, loose mortar and all other forms of contamination. Concrete which has been treated with curing compounds or hardeners, should be thoroughly abraded.

CONCRETE MASONRY UNITS: Allow the mortar to cure for thirty (30) days under normal drying conditions. Remove all dirt, dust, grime, loose mortar and all other forms of contamination.

Recommended Primers

Wood	17-921, 17-955, 17-956
Concrete, Stucco, Plaster, Masonry other than CM Unit	4-603, 4-808
Drywall	6-2, 9-900, 17-921
Aluminum	6-204, 90-712
Ferrous Metal	6-208, 6-212, 7-852, 90-712
Galvanized Steel	6-209, 90-712
Concrete Masonry Units, Masonry (Block Fillers)	6-7, 6-15, 6-16

Directions for Use

Stir thoroughly before using and occasionally when in use. When using more than one can of the same color, mix together (box) before applying. Explosion-proof equipment must be used when coating with these materials in confined areas. Keep containers closed and away from heat, sparks, and flames when not in use. **USE WITH ADEQUATE VENTILATION. KEEP OUT OF REACH OF CHILDREN.** Read all label and Material Safety Data Sheet (MSDS) information prior to use. MSDS are available through our website or by calling 1-800-441-9695.

Permissible temperatures during application:

Material:	50 to 90°F	10 to 32°C
Ambient:	50 to 100°F	10 to 38°C
Substrate:	50 to 110°F	10 to 43°C

Application Information**Recommended Spread Rates:**

Wet Mils :	3.6 minimum to	4.0 maximum
Wet Microns:	91.4 minimum to	101.6 maximum
Dry Mils :	2.0 minimum to	2.2 maximum
Dry Microns:	50.8 minimum to	55.9 maximum

Application Equipment: Changes in application equipment, pressures and/or tip sizes may be required depending on ambient temperatures and application conditions. Spray equipment must be handled with due care and in accordance with manufacturer's recommendation. High-pressure injection of coatings into the skin by airless equipment may cause serious injury.

Conventional Spray: Graco 700 Gun - 217-757. Fluid pressure: 15 lbs. Atomizing pressure: 30-35 lbs.

Airless Spray: Pressure 2000 psi, tip 0.015" - 0.021"

Brush: High Quality Polyester/Nylon Brush

Roller: 3/16" - 3/8" nap roller cover

Thinning:

DO NOT THIN.

Packaging: 1-Gallon (3.78L)

5-Gallon (18.9L)

Not all products are available in all sizes. All containers are not full-filled.

PPGAF believes the technical data presented is currently accurate: however, no guarantee of accuracy, comprehensiveness, or performance is given or implied. Improvements in coatings technology may cause future technical data to vary from what is in this bulletin. For complete, up-to-date technical information, visit our web site or call 1-800-441-9695.



PPG Industries, Inc.
Architectural Coatings
One PPG Place
Pittsburgh, PA 15272
www.ppghcp.com

Technical Services
1-800-441-9695
1-888-807-5123 fax

Architect/Specifier
1-888-PPG-IDEA

PPG Architectural Finishes
400 S. 13th Street
Louisville, KY 40203

PPG Canada, Inc.
Architectural Coatings
4 Kenview Blvd
Brampton, ON L6T 5E4

D7 10/2006

EXHIBIT C

To

**REFURBISHMENT OF BELT CONVEYORS CV-123/223
AT THE
MID-CONNECTICUT WASTE PROCESSING FACILITY
AGREEMENT**

PROJECT SCHEDULE

EXHIBIT C
PROJECT SCHEDULE

Description	Total time	Notes
Field measurement	1 week	12:00 am to 7:00 am Monday through Sunday
Fabrication	6 weeks	Must be delivered on site and stacked before the start of project
Demolition and Installation	80 hours	Start on Friday night @ 2330- End on Tuesday morning @ 0730.

COMPLETION DATE:	Contractor must complete all of work and have such Work ready for CRRA's acceptance at the end of 180 days following the issuance of such Notice To Proceed.
-------------------------	--

EXHIBIT D

To

**REFURBISHMENT OF BELT CONVEYORS CV-123/223
AT THE
MID-CONNECTICUT WASTE PROCESSING FACILITY
AGREEMENT**

COMPENSATION SCHEDULE

COMPENSATION SCHEDULE

[The Compensation Schedule will be added by CRRA based on the successful Bidder's Bid Price Form, as such Form may be modified as a result of negotiations between CRRA and the successful Bidder.]

EXHIBIT E

To

**REFURBISHMENT OF BELT CONVEYORS CV-123/223
AT THE
MID-CONNECTICUT WASTE PROCESSING FACILITY
AGREEMENT**

**PERFORMANCE BOND FORM AND
PERFORMANCE LETTER OF CREDIT FORM**

PERFORMANCE BOND

Any singular reference to Contractor, Surety, Owner or other party shall be considered plural where applicable. The below addresses are to be used for giving required notice.

CONTRACTOR (Name and Address):

SURETY (Name and Principal Place of Business):

--	--

OWNER (Name and Address):

Connecticut Resources Recovery Authority 100 Constitution Plaza, 6 th Floor Hartford, CT 06103-1722
--

AGREEMENT

DATE:	
AGREEMENT NUMBER:	
AMOUNT:	
PROJECT DESCRIPTION <small>(Including Name and Location):</small>	Refurbishment Of Celt Conveyors CV-123/223 at the Mid-Connecticut Waste Processing Facility Mid-Connecticut Waste Processing Facility 300 Maxim Road, Gate 70 Hartford, Connecticut 06114

BOND

BOND NUMBER:	
DATE: <small>(Not earlier than Agreement Date)</small>	
AMOUNT:	DOLLARS (\$ _____)

IN WITNESS WHEREOF, Surety and Contractor, intending to be legally bound hereby, subject to the terms printed on Pages 2 and 3 hereof, do each cause this Performance Bond to be duly executed on its behalf by its authorized officer, agent, or representative.

CONTRACTOR AS PRINCIPAL

SURETY

--

(SEAL)

--

(SEAL)

Contractor's Name and Corporate Seal

Surety's Name and Corporate Seal

SIGNATURE:		SIGNATURE:	
NAME AND TITLE:		NAME AND TITLE:	

TERMS AND CONDITIONS TO PERFORMANCE BOND

1. The Contractor and the Surety jointly and severally bind themselves, their heirs, executors, administrators, successors and assigns to the Owner for the performance of the foregoing Agreement, the terms of which are incorporated herein by reference. Any singular reference to the Contractor, the Surety, the Owner or any other party herein shall be considered plural where applicable.
2. If the Contractor performs the Agreement, the Surety and the Contractor shall have no obligation under this Bond, except to participate in conferences as provided in Subparagraph 3.1.
3. If there is no Owner Default (as hereinafter defined), the Surety's obligation under this Bond shall arise after:
 - 3.1 The Owner has notified the Contractor and the Surety at its address described in Paragraph 10 below, that the Owner is considering declaring a Contractor Default (as hereinafter defined) and has requested and attempted to arrange a conference with the Contractor and the Surety to be held not later than fifteen (15) days after the receipt of such notice to discuss methods of performing the Agreement. If the Owner, the Contractor and the Surety agree, the Contractor shall be allowed a reasonable time to perform the Agreement, but such an agreement shall not waive the Owner's right, if any, to subsequently declare a Contractor Default; and
 - 3.2 The Owner has declared a Contractor Default (as hereinafter defined) and formally terminated the Contractor's right to complete the Agreement. Such Contractor Default shall not be declared earlier than twenty (20) days after the Contractor and the Surety have received notice as provided in Subparagraph 3.1.
 - 3.3 The Owner has agreed to pay the Balance of the Agreement Price to the Surety in accordance with the terms of the Agreement or to a contractor selected to perform the Agreement in accordance with the terms of the agreement with the Owner.
4. When the Owner has satisfied the conditions of Paragraph 3, the Surety shall promptly and at the Surety's expense take one of the following actions:
 - 4.1 Arrange for the Contractor, with the consent of the Owner, to perform and complete the Agreement; or
 - 4.2 Undertake to perform and complete the Agreement itself, through its agents or through independent contractors; or
 - 4.3 Obtain bids or negotiated proposals from qualified contractors acceptable to the Owner for a contract for performance and completion of the Agreement, arrange for a contract to be prepared for execution by the Owner and the contractor selected with the Owner's concurrence, to be secured with a performance bond executed by a qualified surety equivalent to the bond issued on the Agreement, and pay to the Owner the amount of damages described in Paragraph 6; or
 - 4.4 Waive its right to perform and complete, arrange for completion or obtain a new contractor and with reasonable promptness under the circumstances:
 - 4.4.1 After investigation, determine the amount for which it may be liable to the Owner and, as soon as practicable after the amount is determined, tender payment therefor to the Owner; or
 - 4.4.2 Deny liability in whole or in part and notify the Owner citing reasons therefor.
5. If the Surety does not proceed as provided in Paragraph 4 with reasonable promptness, the Surety shall be deemed to be in default on this Bond fifteen (15) days after receipt of an additional written notice from the Owner to the Surety demanding that the Surety perform its obligations under this Bond, and the Owner shall be entitled to enforce any remedy available to the Owner. If the Surety proceeds as provided in Subparagraph 4.4 and the Owner refuses the payment tendered or the Surety has denied liability, in whole or in part, without further notice the Owner shall be entitled to enforce any remedy available to the Owner.
6. After the Owner has terminated the Contractor's right to complete the Agreement, and if the Surety elects to act under Subparagraph 4.1, 4.2 or 4.3 above, then the responsibilities of the Surety to the Owner shall not be greater than those of the Contractor under the Agreement, and the responsibilities of the Owner to the Surety shall not be greater than those of the Owner under the Agreement. To the limit of the amount of this Bond, the Surety is obligated without duplication for:
 - 6.1 The responsibilities of the Contractor for correction of defective work and completion of the Agreement;
 - 6.2 Additional legal and delay costs resulting from the Contractor's Default and resulting from the actions or failure to act of the Surety under Paragraph 4; and
 - 6.3 Liquidated damages, or if no liquidated damages are specified in the Agreement, actual damages caused by delayed performance or non-performance of the Contractor.
7. The Surety shall not be liable to the Owner or others for obligations of the Contractor that are unrelated to the Agreement. No right of action shall accrue on this Bond to any person or entity other than the Owner or its successors and assigns.
8. The Surety hereby waives notice of any change, including changes of time, to the Agreement or to related subcontracts, purchase orders and other obligations.
9. Any proceeding, legal or equitable, under this Bond may be instituted in any court of competent jurisdiction in the location in which the work or part of the work is located and shall be instituted within two (2) years after Contractor Default or within two (2) years after the Contractor ceased working or within two (2) years after the Surety refuses or fails to perform its obligations under this Bond, whichever occurs first. If the provisions

of this Paragraph are void or prohibited by law, the minimum period of limitation available to sureties as a defense in the jurisdiction of the suit shall be applicable.

10. Notice to the Surety, the Owner or the Contractor shall be mailed or delivered to the address shown on the signature page of this Bond.
11. When this Bond has been furnished to comply with a statutory or other legal requirement in the location where the Agreement was to be performed, any provision in this Bond conflicting with said statutory or legal requirement shall be deemed deleted here from and provisions confirming to such statutory or other legal requirement shall be deemed incorporated herein. The intent is that this Bond shall be construed as a statutory bond and not as a common law bond.
12. Definitions.

12.1 Balance of the Agreement Price: The total amount payable by the Owner to the Contractor under the Agreement after all proper adjustments have been made, including allowance to the Contractor of any amounts received or to be received by the Owner in settlement of insurance or other claims for damages to which the Contractor is entitled, reduced by all valid and proper payments made to or on behalf of the Contractor under the Agreement.

12.2 Agreement: The agreement between the Owner and the Contractor identified on the signature page, including all Agreement Documents and changes thereto.

12.3 Contractor Default: Failure of the Contractor, which has neither been remedied nor waived, to perform or otherwise to comply with any of the terms of the Agreement.

12.4 Owner Default: Failure of the Owner, which has neither been remedied nor waived, to perform or otherwise to comply with the terms of the Agreement or to perform and complete or comply with the other terms hereof.

LETTER OF CREDIT

To Be Issued By a Connecticut Bank Or By a National Banking Association

Irrevocable Standby Letter Of Credit No.		[Letter Of Credit #]	
Issuance Date:	[Date]	Expiration Date:	[Date]
Beneficiary:	Connecticut Resources Recovery Authority 100 Constitution Plaza, 6th Floor Hartford, CT 06103		

Gentlemen:

We hereby establish our Irrevocable Standby Letter Of Credit No. [Letter Of Credit #] in favor of the "Beneficiary," Connecticut Resources Recovery Authority ("CRRA"), at the request and for the account of [Name of Contractor], for the sum or sums up to the aggregate amount of [amount of Letter Of Credit] available for payment against your draft(s) at sight on us.

Drafts must be drawn and presented to us at this office not later than our close of business on [Date] or any duly extended expiration date, and each draft must bear the following clause: "Drawn Under Letter Of Credit No. [Letter Of Credit #]."

Drafts must be accompanied by a certified statement from the Beneficiary that [name of Contractor] has failed to satisfy or perform one or more of its obligations or breached one or more of its covenants or representations under a certain Refurbishment Of Belt Conveyors CV-123/223 At The Mid-Connecticut Waste Processing Facility Agreement between [name of Contractor] and CRRA, dated as of [Date].

Partial drawings hereunder are permitted.

We hereby agree with you that drafts drawn under and in compliance with the above terms of this Letter Of Credit shall be duly and promptly honored on due presentation and delivery to us on or before the above-referenced expiration date or any duly extended expiration date.

The term "Beneficiary" includes any successor by operation of law of the named Beneficiary including, without limitation, any liquidator, rehabilitator, receiver or conservator.

Except as expressly stated herein, this undertaking is not subject to any agreement, condition or qualification. The obligation of [name of the issuing Connecticut Bank or National Banking Association] under this Letter of Credit is the individual obligation of [name of the issuing Connecticut Bank or National Banking Association] and is in no way contingent upon reimbursement with respect thereto.

It is a condition of this Letter Of Credit that it is deemed to be automatically extended without amendment for one (1) year from the expiration date stated above, or any future expiration date, unless not later than ninety (90) days prior to the expiration date stated above or the then current expiration date we notify you by registered mail that we elect not to renew this Letter Of Credit for any such additional period.

We hereby agree that all drafts drawn under and in compliance with the terms of this Letter Of Credit shall be duly honored by us at your first demand, notwithstanding any contestation or dispute between you and **[name of Contractor]**, if presented to us in accordance with the provisions hereof.

This Letter of Credit is subject to and governed by the laws of the State of Connecticut, the decisions of the courts of that state, and the Uniform Customs and Practice for Documentary Credits (1993 Revision) International Chamber of Commerce Publication No. 500 and in the event of any conflict, the laws of the State of Connecticut and the decisions of the courts of that state will control. If this Letter Of Credit expires during an interruption of business of this bank as described in Article 17 of said Publication 500, **[name of issuing Connecticut Bank or National Banking Association]** hereby specifically agrees to effect payment if this Letter of Credit is drawn against within thirty (30) days after the resumption of business from such interruption.

Very truly yours,

Authorized Signature for
[name of issuing Connecticut Bank or National Banking Association]

EXHIBIT F

To

**REFURBISHMENT OF BELT CONVEYORS CV-123/223
AT THE
MID-CONNECTICUT WASTE PROCESSING FACILITY
AGREEMENT**

PAYMENT BOND FORM

CONSTRUCTION PAYMENT BOND

Any singular reference to Contractor, Surety, Owner or other party shall be considered plural where applicable. The below addresses are to be used for giving required notice.

CONTRACTOR (Name and Address):

SURETY (Name and Principal Place of Business):

--	--

OWNER (Name and Address):

Connecticut Resources Recovery Authority 100 Constitution Plaza, 6 th Floor Hartford, CT 06103-1722
--

AGREEMENT

DATE:	
AGREEMENT NUMBER:	
AMOUNT:	
PROJECT DESCRIPTION <small>(Including Name and Location):</small>	Refurbishment Of Belt Conveyors CV-123/223 at the Mid-Connecticut Waste Processing Facility Mid-Connecticut Waste Processing Facility 300 Maxim Road, Gate 20 Hartford, Connecticut 06114

BOND

BOND NUMBER:	
DATE: <small>(Not earlier than Agreement Date)</small>	
AMOUNT:	DOLLARS (\$ _____)

IN WITNESS WHEREOF, Surety and Contractor, intending to be legally bound hereby, subject to the terms printed on Pages 2 and 3 hereof, do each cause this Payment Bond to be duly executed on its behalf by its authorized officer, agent, or representative.

CONTRACTOR AS PRINCIPAL

SURETY

--

(SEAL)

--

(SEAL)

Contractor's Name and Corporate Seal

Surety's Name and Corporate Seal

SIGNATURE:		SIGNATURE:	
NAME AND TITLE:		NAME AND TITLE:	

TERMS AND CONDITIONS TO CONSTRUCTION PAYMENT BOND

1. The Contractor and the Surety, jointly and severally, bind themselves, their heirs, executors, administrators, successors and assigns to the Owner to pay for labor, materials and equipment furnished for use in the performance of the Agreement, which is incorporated herein by reference.

thereof, to the Owner, stating that a claim is being made under this Bond and enclosing a copy of the previous written notice furnished to the Contractor.
2. With respect to the Owner, this obligation shall be null and void if the Contractor:
 - 2.1 Promptly makes payment, directly or indirectly, for all sums due Claimants, and
 - 2.2 Defends, indemnifies and holds harmless the Owner from claims, demands, liens or suits by any person or entity whose claim, demand, lien or suit is for the payment for labor, materials or equipment furnished for use in the performance of the Agreement, provided the Owner has promptly notified the Contractor and the Surety (at the address described in Paragraph 12) of any claims, demands, liens or suits and tendered defense of such claims, demands, liens or suits to the Contractor and the Surety, and provided there is no Owner Default.
3. With respect to Claimants, this obligation shall be null and void if the Contractor promptly makes payment, directly or indirectly, for all sums due.
4. The Surety shall have no obligation to Claimants under this Bond until:
 - 4.1 Claimants who are employed by or have a direct contract with the Contractor have given notice to the Surety (at the address described in Paragraph 12) and sent a copy, or notice thereof, to the Owner, stating that a claim is being made under this Bond and, with substantial accuracy, the amount of the claim.
 - 4.2 Claimants who do not have a direct contract with the Contractor:
 - 4.2.1 Have furnished written notice to the Contractor and sent a copy, or notice thereof to the Owner, within 90 days after having last performed labor or last furnished materials or equipment included in the claim stating, with substantial accuracy, the amount of the claim and the name of the party to whom the materials were furnished or supplied or for whom the labor was done or performed; and
 - 4.2.2 Have either received a rejection in whole or in part from the Contractor, or not received within 30 days of furnishing the above notice any communication from the Contractor by which the Contractor has indicated the claim will be paid directly or indirectly; and
 - 4.2.3 Not having been paid within the above 30 days, have sent a written notice to the Surety (at the address described in Paragraph 12) and sent a copy, or notice
5. If a notice required by Paragraph 4 is given by the Owner to the Contractor or to the Surety, that is sufficient compliance.
6. When the Claimant has satisfied the conditions of Paragraph 4, the Surety shall promptly and at the Surety's expense take the following actions:
 - 6.1 Send an answer to the Claimant, with a copy to the Owner, within 45 days after receipt of the claim, stating the amounts that are undisputed and the basis for challenging any amounts that are disputed.
 - 6.2 Pay or arrange for payment of any undisputed amounts.
7. The Surety's total obligation shall not exceed the amount of this Bond, and the amount of this Bond shall be credited for any payments made in good faith by the Surety.
8. Amounts owed by the Owner to the Contractor under the Agreement shall be used for the performance of the Agreement and to satisfy claims, if any, under any Performance Bond. By the Contractor furnishing and the Owner accepting this Bond, they agree that all funds earned by the Contractor in the performance of the Agreement are dedicated to satisfy obligations of the Contractor and the Surety under this Bond, subject to the Owner's priority to use the funds for the completion of the work.
9. The Surety shall not be liable to the Owner, Claimants or others for obligations of the Contractor that are unrelated to the Agreement. The Owner shall not be liable for payment of any costs or expenses of any Claimant under this Bond, and shall have under this Bond no obligations to make payments to, give notices on behalf of, or otherwise have obligations to Claimants under this Bond.
10. The Surety hereby waives notice of any change, including changes of time, to the Agreement or to related subcontracts, purchase orders and other obligations.
11. No suit or action shall be commenced by a Claimant under this Bond other than in a court of competent jurisdiction in the location in which the work or part of the work is located or after the expiration of one year from the date (1) on which the Claimant gave the notice required by Subparagraph 4.1 or Clause 4.2.3, or (2) on which the last labor or service was performed by anyone or the last materials or equipment were furnished by anyone under the Agreement, whichever of (1) or (2) first occurs. If the provisions of this Paragraph are void or prohibited by law, the minimum period of limitation available to sureties as a defense in the jurisdiction of the suit shall be applicable.

12. Notice to the Surety, the Owner or the Contractor shall be mailed or delivered to the address shown on the signature page. Actual receipt of notice by Surety, the Owner or the Contractor, however accomplished, shall be sufficient compliance as of the date received at the address shown on the signature page.
13. When this Bond has been furnished to comply with a statutory or other legal requirement in the location where the construction was to be performed, any provision in this Bond conflicting with said statutory or legal requirement shall be deemed deleted herefrom and provisions conforming to such statutory or other legal requirement shall be deemed incorporated herein. The intent is that this Bond shall be construed as a statutory bond and not as a common law bond.
14. Upon request by any person or entity appearing to be a potential beneficiary of this Bond, the Contractor shall promptly furnish a copy of this Bond or shall permit a copy to be made.
15. Definitions
 - 15.1 Claimant: An individual or entity having a direct contract with the Contractor or with a subcontractor of the Contractor to furnish labor, materials or

equipment for use in the performance of the Agreement. The intent of this Bond shall be to include without limitation in the terms "labor, materials or equipment" that part of water, gas, power, light, heat, oil, gasoline, telephone service or rental equipment used in the Agreement, architectural and engineering services required for performance of the work of the Contractor and the Contractor's subcontractors, and all other items for which a mechanic's lien may be asserted in the jurisdiction where the labor, materials or equipment were furnished,

- 15.2 Agreement: The agreement between the Owner and the Contractor identified on the signature page, including all Agreement Documents and changes thereto.
- 15.3 Owner Default: Failure of the Owner, which has neither been remedied nor waived, to pay the Contractor as required by the Agreement or to perform and complete or comply with the other terms thereof.

EXHIBIT G

To

**REFURBISHMENT OF BELT CONVEYORS CV-123/223
AT THE
MID-CONNECTICUT WASTE PROCESSING FACILITY
AGREEMENT**

PREVAILING WAGE BID PACKAGE

Prevailing Wage Bid Package

Last Updated: July 03, 2007

You are here: [DOL Web Site](#) › [Wage and Workplace Issues](#) › Prevailing Wage Bid Package

- › [Section 31-53b: Construction safety and Health Course. Proof of completion](#)
required for employees on public building projects. (PDF, 10KB)
 - › [Informational Bulletin - The 10-Hour OSHA Construction Safety and Health Course](#) (PDF, 20KB)
- › [Notice For All Mason Contractors](#) (PDF, 5KB)
- › [CT General Statute 31-55a](#)
- › [Contracting Agency Certification Form](#) (PDF, 89KB)
- › [Contractor's Wage Certification Form](#) (PDF, 11KB)
- › [Payroll Certification - Public Works Projects](#)
- › [Occupational Classification Bulletin](#)
- › [Footnotes](#) (PDF, 101KB)

Published by the Connecticut Department of Labor, Automation Support Unit

Sec. 31-53b. Construction safety and health course. Proof of completion required for employees on public building projects. Enforcement. Regulations. (a) Each contract entered into on or after July 1, 2007, for the construction, remodeling, refinishing, refurbishing, rehabilitation, alteration or repair of any public building project by the state or any of its agents, or by an political subdivision of the state or any of its agents, where the total cost of all work to be performed by all contractors and subcontractors in connection with the contract is at least one hundred thousand dollars, shall contain a provision requiring that, not later than thirty days after the date such contract is awarded, each contractor furnish proof to the Labor Commissioner that all employees performing manual labor on or in such public building, pursuant to such contract, have completed a course of at least ten hours in duration in construction safety and health approved by the federal Occupational Safety and Health Administration or, in the case of telecommunications employees, have completed at least ten hours of training in accordance with 29 CFR 1910.268.

(b) Any employee required to complete a construction safety and health course required under subsection (a) of this section who has not completed the course shall be subject to removal from the worksite if the employee does not provide documentation of having completed such course by the fifteenth day after the date the employee is found to be in noncompliance. The Labor Commissioner or said commissioner's designee shall enforce this section.

(c) Not later than January 1, 2007, the Labor Commissioner shall adopt regulations, in accordance with the provisions of chapter 54, to implement the provisions of subsections (a) and (b) of this section. Such regulations shall require that the ten-hour construction safety and health courses required under subsection (a) of this section be conducted in accordance with federal Occupational Safety and Health Administration Training Institute standards, or in accordance with 29 CFR 1910.268, as appropriate. The Labor Commissioner shall accept as sufficient proof of compliance with the provisions of subsection (a) or (b) of this section a student course completion card issued by the federal Occupational Safety and Health Administration Training Institute, or such other proof of compliance said commissioner deems appropriate, dated no earlier than five years before the commencement date of such public works project.

(d) For the purposes of this section, "public building" means a structure, paid for in whole or in part with state funds, within a roof and within exterior walls or fire walls, designed for the housing, shelter, enclosure and support or employment of people, animals or property of any kind, including, but not limited to, sewage treatment plants and water treatment plants, "Public building" does not include site work, roads or bridges, rail lines, parking lots or underground water, sewer or drainage systems including pump houses or other utility systems.

Informational Bulletin

THE 10-HOUR OSHA CONSTRUCTION SAFETY AND HEALTH COURSE

(applicable to public building contracts entered into *on or after July 1, 2007*, where the total cost of all work to be performed is at least \$100,000)

- (1) This requirement was created by Public Act No. 06-175, which is codified in Section 31-53b of the Connecticut General Statutes (pertaining to the prevailing wage statutes);
- (2) The course is required for public building construction contracts (projects funded in whole or in part by the state or any political subdivision of the state) entered into on or after July 1, 2007;
- (3) It is required of private employees (not state or municipal employees) and apprentices who perform manual labor for a general contractor or subcontractor on a public building project where the total cost of all work to be performed is at least \$100,000;
- (4) The ten-hour construction course pertains to the ten-hour Outreach Course conducted in accordance with federal OSHA Training Institute standards, and, for telecommunications workers, a ten-hour training course conducted in accordance with federal OSHA standard, 29 CFR 1910.268;
- (5) The internet website for the federal OSHA Training Institute is http://www.osha.gov/fso/ote/training/edcenters/fact_sheet.html;
- (6) The statutory language leaves it to the contractor and its employees to determine who pays for the cost of the ten-hour Outreach Course;
- (7) Within 30 days of receiving a contract award, a general contractor must furnish proof to the Labor Commissioner that all employees and apprentices performing manual labor on the project will have completed such a course;
- (8) Proof of completion may be demonstrated through either: (a) the presentation of a *bona fide* student course completion card issued by the federal OSHA Training Institute; *or* (2) the presentation of documentation provided to an employee by a trainer certified by the Institute pending the actual issuance of the completion card;
- (9) Any card with an issuance date more than 5 years prior to the commencement date of the construction project shall not constitute proof of compliance;

- (10) Each employer shall affix a copy of the construction safety course completion card to the certified payroll submitted to the contracting agency in accordance with Conn. Gen. Stat. § 31-53(f) on which such employee's name first appears;
- (11) Any employee found to be in non-compliance shall be subject to removal from the worksite if such employee does not provide satisfactory proof of course completion to the Labor Commissioner by the fifteenth day after the date the employee is determined to be in noncompliance;
- (12) Any such employee who is determined to be in noncompliance may continue to work on a public building construction project for a maximum of fourteen consecutive calendar days while bringing his or her status into compliance;
- (13) The Labor Commissioner may make complaint to the prosecuting authorities regarding any employer or agent of the employer, or officer or agent of the corporation who files a false certified payroll with respect to the status of an employee who is performing manual labor on a public building construction project;
- (14) The statute provides the minimum standards required for the completion of a safety course by manual laborers on public construction contracts; any contractor can exceed these minimum requirements; and
- (15) Regulations clarifying the statute are currently in the regulatory process, and shall be posted on the CTDOL website as soon as they are adopted in final form.
- (16) Any questions regarding this statute may be directed to the Wage and Workplace Standards Division of the Connecticut Labor Department via the internet website of <http://www.ctdol.state.ct.us/wgwkstnd/wgemenu.htm>; or by telephone at (860)263-6790.

THE ABOVE INFORMATION IS PROVIDED EXCLUSIVELY AS AN EDUCATIONAL RESOURCE, AND IS NOT INTENDED AS A SUBSTITUTE FOR LEGAL INTERPRETATIONS WHICH MAY ULTIMATELY ARISE CONCERNING THE CONSTRUCTION OF THE STATUTE OR THE REGULATIONS.

November 29, 2006

Notice
To All Mason Contractors and Interested Parties
Regarding Construction Pursuant to Section 31-53 of the
Connecticut General Statutes (Prevailing Wage)

The Connecticut Labor Department Wage and Workplace Standards Division is empowered to enforce the prevailing wage rates on projects covered by the above referenced statute.

Over the past few years the Division has withheld enforcement of the rate in effect for workers who operate a forklift on a prevailing wage rate project due to a potential jurisdictional dispute.

The rate listed in the schedules and in our Occupational Bulletin (see enclosed) has been as follows:

Forklift Operator:

- **Laborers (Group 4) Mason Tenders** - operates forklift solely to assist a mason to a maximum height of nine feet only.
- **Power Equipment Operator (Group 9)** - operates forklift to assist any trade and to assist a mason to a height over nine feet.

The U.S. Labor Department conducted a survey of rates in Connecticut but it has not been published and the rate in effect remains as outlined in the above Occupational Bulletin.

Since this is a classification matter and not one of jurisdiction, effective January 1, 2007 the Connecticut Labor Department will enforce the rate on each schedule in accordance with our statutory authority.

Your cooperation in filing appropriate and accurate certified payrolls is appreciated.

Statute 31-55a

Last Updated: December 06, 2007

You are here: [DOL Web Site](#) › [Wage and Workplace Issues](#) › Statute 31-55a

- Special Notice -

To All State and Political Subdivisions, Their Agents, and Contractors

Connecticut General Statute 31-55a - Annual adjustments to wage rates by contractors doing state work.

Each contractor that is awarded a contract on or after October 1, 2002, for (1) the construction of a state highway or bridge that falls under the provisions of section 31-54 of the general statutes, or (2) the construction, remodeling, refinishing, refurbishing, rehabilitation, alteration or repair of any public works project that falls under the provisions of section 31-53 of the general statutes shall contact the Labor Commissioner on or before July first of each year, for the duration of such contract, to ascertain the prevailing rate of wages on an hourly basis and the amount of payment or contributions paid or payable on behalf of each mechanic, laborer or worker employed upon the work contracted to be done, and shall make any necessary adjustments to such prevailing rate of wages and such payment or contributions paid or payable on behalf of each such employee, effective each July first.

- The prevailing wage rates applicable to any contract or subcontract awarded on or after October 1, 2002 are subject to annual adjustments each July 1st for the duration of any project which was originally advertised for bids on or after October 1, 2002.
- Each contractor affected by the above requirement shall pay the annual adjusted prevailing wage rate that is in effect each July 1st, as posted by the Department of Labor.
- It is the **contractor's** responsibility to obtain the annual adjusted prevailing wage rate increases directly from the Department of Labor's Web Site. The annual adjustments will be posted on the Department of Labor Web page: www.ctdol.state.ct.us. For those without internet access, please contact the division listed below.
- The Department of Labor will continue to issue the initial prevailing wage rate schedule to the Contracting Agency for the project. All subsequent annual adjustments will be posted on our Web Site for contractor access.

Any questions should be directed to the Contract Compliance Unit, Wage and Workplace Standards Division, Connecticut Department of Labor, 200 Folly Brook Blvd., Wethersfield, CT 06109 at (860)263-6790.

[Workplace Laws](#)

Published by the Connecticut Department of Labor, Automation Support Unit

~NOTICE~

TO ALL CONTRACTING AGENCIES

Please be advised that Connecticut General Statutes Section 31-53, requires the contracting agency to certify to the Department of Labor, the total dollar amount of work to be done in connection with such public works project, regardless of whether such project consists of one or more contracts.

Please find the attached "Contracting Agency Certification Form" to be completed and returned to the Department of Labor, Wage and Workplace Standards Division, Public Contract Compliance Unit.

📎 Inquiries can be directed to (860)263-6543.

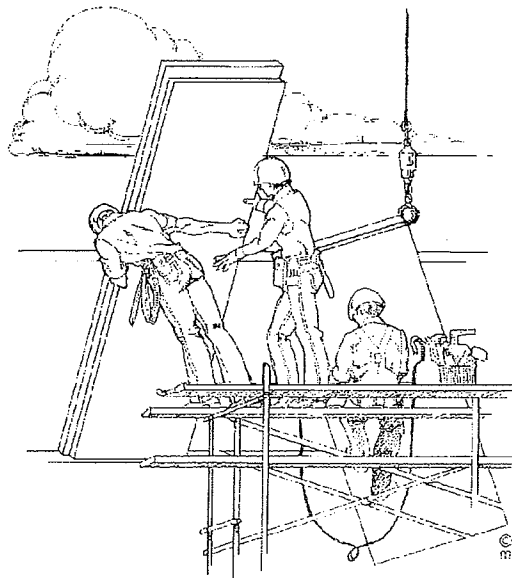

CONNECTICUT DEPARTMENT OF LABOR
WAGE AND WORKPLACE STANDARDS DIVISION
CONTRACT COMPLIANCE UNIT

CONTRACTING AGENCY CERTIFICATION FORM

I, _____, acting in my official capacity as _____,
authorized representative title

for _____, located at _____,
contracting agency address

do hereby certify that the total dollar amount of work to be done in connection with

_____, located at _____,
project name and number address

shall be \$ _____, which includes all work, regardless of whether such project
consists of one or more contracts.

CONTRACTOR INFORMATION

Name: _____

Address: _____

Authorized Representative: _____

Approximate Starting Date: _____

Approximate Completion Date: _____

Signature

Date

Return To: Connecticut Department of Labor
Wage & Workplace Standards Division
Contract Compliance Unit
200 Folly Brook Blvd.
Wethersfield, CT 06109

Date Issued: _____

CONNECTICUT DEPARTMENT OF LABOR
WAGE AND WORKPLACE STANDARDS DIVISION

CONTRACTORS WAGE CERTIFICATION FORM

I, _____ of _____
Officer, Owner, Authorized Rep. Company Name

do hereby certify that the _____
Company Name

Street

City

and all of its subcontractors will pay all workers on the

Project Name and Number

Street and City

the wages as listed in the schedule of prevailing rates required for such project (a copy of which is attached hereto).

Signed

Subscribed and sworn to before me this _____ day of _____.

Notary Public

 Return to:

Connecticut Department of Labor
Wage & Workplace Standards Division
200 Folly Brook Blvd.
Wethersfield, CT 06109

Certified Payroll Form WWS - CPI

Last Updated: February 20, 2008

You are here: [DOL Web Site](#) › [Wage and Workplace Issues](#) › Certified Payroll Form WWS - CPI

In accordance with [Connecticut General Statutes, 31-53](#) Certified Payrolls with a statement of compliance shall be submitted monthly to the contracting agency.

Note: Once you have downloaded these forms and are ready to print them out, set the print function on your PC to the horizontal print orientation.

Note2: Please download both the Payroll Certification for Public Works Projects and the Certified Statement of Compliance for a complete package. The Certified Statement of Compliance appears on the same page as the Fringe Benefits Explanation page.

Announcement: The Certified Payroll Form WWS-CPI can now be completed on-line!

updated [Certified Payroll Form WWS-CPI](#) (PDF, 3.6MB)

Published by the Connecticut Department of Labor, Automation Support Unit

[New] In accordance with Section 31-53b(a) of the C.G.S. each contractor shall provide a copy of the OSHA 10 Hour Construction Safety and Health Card for each employee, to be attached to the first certified payroll on the project.

PAYROLL CERTIFICATION FOR PUBLIC WORKS PROJECTS
WEEKLY PAYROLL

Connecticut Department of Labor
Wage and Workplace Standards Division
200 Folly Brook Blvd.
Wethersfield, CT 06109

CONTRACTOR NAME AND ADDRESS: _____ WORKER'S COMPENSATION INSURANCE CARRIER: _____

PAYROLL NUMBER: _____ POLICY #: _____

PERSON/WORKER AND ADDRESS: _____ EFFECTIVE DATE: _____

Week-Ending Date: _____ EXPIRATION DATE: _____

PERSON/WORKER AND ADDRESS	APPR/MALE/ RATE/FEMALE AND RACE*	WORK CLASSIFICATION Trade License Type & Number OR OSHA 10 Certification Number	DAY AND DATE							Total ST Hours	Total O/T Hours	GROSS PAY FOR ALL WORK PERFORMED THIS WEEK	TOTAL DEDUCTIONS			GROSS PAY FOR THIS PREVAILING RATE JOB	CHECK # AND NET PAY		
			S	M	T	W	TH	F	S				FICA	WITH- HOLDING	WITH- HOLDING			OTHER	
PROJECT NAME & ADDRESS			HOURS WORKED EACH DAY									TYPE OF FRINGE BENEFITS Per Hour 1 through 6 (see back)							
												BASE HOURLY RATE							
												TOTAL FRINGE BENEFIT PLAN CASH							
											S-TIME	\$	1. \$						
											O-TIME	\$	2. \$						
											S-TIME	\$	3. \$						
											O-TIME	\$	4. \$						
											S-TIME	\$	5. \$						
											O-TIME	\$	6. \$						
											S-TIME	\$	1. \$						
											O-TIME	\$	2. \$						
											S-TIME	\$	3. \$						
											O-TIME	\$	4. \$						
											S-TIME	\$	5. \$						
											O-TIME	\$	6. \$						
											S-TIME	\$	1. \$						
											O-TIME	\$	2. \$						
											S-TIME	\$	3. \$						
											O-TIME	\$	4. \$						
											S-TIME	\$	5. \$						
											O-TIME	\$	6. \$						

*IF REQUIRED

2/13/2008
WWW-S-CP1

*SEE REVERSE SIDE

PAGE NUMBER _____ OF _____

OSHA ~ ATTACH CARD TO 1ST CERTIFIED PAYROLL

***FRINGE BENEFITS EXPLANATION (P):**

Bona fide benefits paid to approved plans, funds or programs, except those required by Federal or State Law (unemployment tax, worker's compensation, income taxes, etc.)

Please specify the type of benefits provided:

- 1) Medical or hospital care
- 2) Pension or retirement
- 3) Life Insurance
- 4) Disability
- 5) Vacation, holiday
- 6) Other (please specify)

CERTIFIED STATEMENT OF COMPLIANCE

For the week ending date of _____,

I, _____ of _____, (hereafter known as Employer)

in my capacity as _____ (title) do hereby certify and state:

1. All persons employed on said project have been paid the full weekly wages earned by them during the week in accordance with Connecticut General Statutes, section 31-53, as amended. Further, I hereby certify and state the following:

- A) The records submitted are true and accurate;
- B) The rate of wages paid to each mechanic, laborer or workman and the amount of payment or contributions paid or payable on behalf of each such employee to any employee welfare fund, as defined in Connecticut General Statutes, section 31-53 (h), are not less than the prevailing rate of wages and the amount of payment or contributions paid or payable on behalf of each such employee to any employee welfare fund, as determined by the Labor Commissioner pursuant to subsection Connecticut General Statutes, section 31-53 (d), and said wages and benefits are not less than those which may also be required by contract;
- C) The Employer has complied with all of the provisions in Connecticut General Statutes, section 31-53 (and Section 31-54 if applicable for state highway construction);
- D) Each such employee of the Employer is covered by a worker's compensation insurance policy for the duration of his employment which proof of coverage has been provided to the contracting agency;
- E) The Employer does not receive kickbacks, which means any money, fee, commission, credit, gift, gratuity, thing of value, or compensation of any kind which is provided directly or indirectly, to any prime contractor, prime contractor employee, subcontractor, or subcontractor employee for the purpose of improperly obtaining or rewarding favorable treatment in connection with a prime contract or in connection with a prime contractor in connection with a subcontractor relating to a prime contractor; and
- F) The Employer is aware that filing a certified payroll which he knows to be false is a class D felony for which the employer may be fined up to five thousand dollars, imprisoned for up to five years or both.

2. OSHA-Certified Statement

Submitted on

(Date)

(Signature)

(Title)

THIS IS A PUBLIC DOCUMENT
DO NOT INCLUDE SOCIAL SECURITY NUMBERS

PAYROLL CERTIFICATION FOR PUBLIC WORKS PROJECTS

Weekly Payroll Certification For Public Works Projects (Continued)

Week-Ending Date: _____
Contractor or Subcontractor Business Name: _____

WEEKLY PAYROLL

PERSON/WORKER AND ADDRESS	APPR RATE %	MALE/FEMALE AND RACE*	WORK CLASSIFICATION <small>Trade License Type & Number OR OSHA 10 Certification Number</small>	DAY AND DATE							Total Hours	BASE HOURLY RATE	TYPE OF FRINGE BENEFITS	GROSS PAY FOR ALL WORK PERFORMED THIS WEEK	TOTAL DEDUCTIONS			GROSS PAY FOR THIS PREVAILING RATE JOB	CHECK # AND NET PAY						
				S	M	T	W	TH	F	S					FEDERAL STATE	FICA WITH-HOLDING	OTHER								
				HOURS WORKED EACH DAY											Per Hour 1 through 6 (see back)	WITH-HOLDING	OTHER								
											1. \$														
											2. \$														
											3. \$														
											4. \$														
											5. \$														
											6. \$														
											1. \$														
											2. \$														
											3. \$														
											4. \$														
											5. \$														
											6. \$														
											1. \$														
											2. \$														
											3. \$														
											4. \$														
											5. \$														
											6. \$														
											1. \$														
											2. \$														
											3. \$														
											4. \$														
											5. \$														
											6. \$														
											1. \$														
											2. \$														
											3. \$														
											4. \$														
											5. \$														
											6. \$														

*IF REQUIRED

NOTICE: THIS PAGE MUST BE ACCOMPANIED BY A COVER PAGE (FORM # WWS-CPI)

Occupational Classification Bulletin

Last Updated: March 13, 2008

You are here: [DOL Web Site](#) › [Wage and Workplace Issues](#) › Occupational Classification Bulletin

- **new** [Informational Bulletin - 03/12/08](#) (PDF, 1.63MB)

Published by the Connecticut Department of Labor, Automation Support Unit

Revised: March 12, 2008

Informational Bulletin

Occupational Classifications

The Connecticut Department of Labor has the responsibility to properly determine "job classification" on prevailing wage projects covered under C.G.S. Section 31-53.

✓Note: This information is intended to provide a sample of some occupational classifications for guidance purposes only. It is not an all-inclusive list of each occupation's duties. This list is being provided only to highlight some areas where a contractor may be unclear regarding the proper classification.

On any construction project, an assortment of workers are needed to carry out all of the required tasks. Employees include various skilled crafts people, machine operators, general laborers, and apprentices. Prevailing wage rate schedules identify the classes of workers likely to be employed on each of the four types of construction projects. (If a contractor wants to use a class of worker not listed in a wage determination, there is a process for requesting the U.S. Department of Labor to establish a prevailing wage rate for that additional classification). (Contact U.S. Department of Labor at 202.693.0062 or 215.861.5800)

A registered apprentice is not a separate prevailing wage job classification. Apprentices are paid a percentage of the base rate received by the craft that they are training to become and the full fringe rate. This percentage increases in steps, as the apprentice advances through the stages of the apprenticeship process.

 Any questions regarding the proper classification should be directed to the Contract Compliance Unit, Wage and Workplace Standards Division, Connecticut Department of Labor, 200 Folly Brook Blvd, Wethersfield, CT 06109 at 860.263.6543.

Below are additional clarifications of specific job duties performed for certain classifications:

⇒ ASBESTOS WORKERS/INSULATORS:

- ▶ Handle, install, apply, fabricate, distribute, prepare, alter, repair, or dismantle heat and frost insulation, including penetration and fire stopping work on all penetration fire stop systems.

⇒ BOILERMAKERS:

- ▶ Erects hydro plants, incomplete vessels, steel stacks, storage tanks for water, fuel, etc. Builds incomplete boilers, repairs heat exchanges and steam generators.

⇒ BRICKLAYERS, CEMENT MASONS, CEMENT FINISHERS, MARBLE MASONS, PLASTERERS, STONE MASONS, PLASTERERS, STONE MASONS, TERRAZZO WORKERS, TILE SETTERS:

- ▶ Lays building materials such as brick, structural tile and concrete cinder, glass, gypsum, terra cotta block. Cuts, tools and sets marble, sets stone, finishes concrete, applies decorative steel, aluminum and plastic tile, applies cements, sand, pigment and marble chips to floors, stairways, etc.

⇒ CARPENTERS, MILLWRIGHTS, PILEDRIVERMEN, LATHERS, RESILIENT FLOOR LAYERS, DOCK BUILDERS, DIVERS, DIVER TENDERS:

- ▶ Constructs, erects, installs and repairs structures and fixtures of wood, plywood and wallboard. Installs, assembles, dismantles, moves industrial machinery. Drives piling into ground to provide foundations for structures such as buildings and bridges, retaining walls for earth embankments, such as cofferdams. Fastens wooden, metal or rockboard lath to walls, ceilings and partitions of buildings, acoustical tile layer, concrete form builder. Applies firestopping materials on fire resistive joint systems only. Installation of curtain/window walls only where attached to wood or metal studs.
- ▶ Assembly and installation of modular furniture/furniture systems.
[New] a. Free-standing furniture is not covered. This includes: student chairs, study top desks, book box desks, computer furniture, dictionary stand, atlas stand, wood shelving, two-position information access station, file cabinets, storage cabinets, tables, etc.

⇒ CLEANING LABORER:

- ▶ The clean up of any construction debris and the general cleaning, including sweeping, wash down, mopping, wiping of the construction facility, washing, polishing, dusting, etc., prior to the issuance of a certificate of occupancy falls under the *Labor classification*.

⇒DELIVERY PERSONNEL:

- ▶ If delivery of supplies/building materials is to one common point and stockpiled there, prevailing wages are not required. If the delivery personnel are involved in the distribution of the material to multiple locations within the construction site then they would have to be paid prevailing wages for the type of work performed: laborer, equipment operator, electrician, ironworker, plumber, etc.
- ▶ An example of this would be where delivery of drywall is made to a building and the delivery personnel distribute the drywall from one "stockpile" location to further sub-locations on each floor. Distribution of material around a construction site is the job of a laborer/tradesman and not a delivery personnel.

⇒ELECTRICIANS:

- ▶ Install, erect, maintenance, alteration or repair of any wire, cable, conduit, etc., which generates, transforms, transmits or uses electrical energy for light, heat, power or other purposes. ***License required per Connecticut General Statutes: E-1,2 L-5,6 C-5,6 T-1,2 L-1,2 V-1,2,7,8,9.**

⇒ELEVATOR CONSTRUCTORS:

- ▶ Install, erect, maintenance and repair of all types of elevators, escalators, dumb waiters and moving walks. ***License required by Connecticut General Statutes: R-1,2,5,6.**

⇒FORK LIFT OPERATOR:

- ▶ Laborers Group 4) Mason Tenders - operates forklift solely to assist a mason to a maximum height of nine (9) feet only.
- ▶ Power Equipment Operator Group 9 - operates forklift to assist any trade, and to assist a mason to a height over nine (9) feet.

⇒GLAZIERS: [updated]

- ▶ Installs light metal sash, head sills, and 2-story aluminum commercial storefronts.

⇒IRONWORKERS:

- ▶ Handling, sorting, and installation of reinforcing steel (rebar).
- ▶ Installation of aluminum window walls and curtain walls.
- ▶ Metal bridge rail (traffic), metal bridge handrail, and decorative security fence installation.
- ▶ Installation of handrails, stairs, and platforms installed on Wastewater Treatment Plant projects. [new]

⇒INSULATOR:

- ▶ Installing fire stopping systems/materials for "Penetration Firestop Systems": transit to cables, electrical conduits, insulated pipes, sprinkler pipe penetrations, ductwork behind radiation, electrical cable trays, fire rated pipe penetrations, natural polypropylene, HVAC ducts, plumbing bare metal, telephone and communication wires, and boiler room ceilings. Past practice using the applicable licensed trades, Plumber, Sheet Metal, Sprinkler Fitter, and Electrician, is not inconsistent with the Insulator classification and would be permitted.

⇒LEAD PAINT REMOVAL:

- ▶ Painter Rate -
 - 1) Removal of lead paint from bridges.
 - 2) Removal of lead paint as preparation of any surface to be repainted.
 - 3) Where removal is on a *Demolition* project prior to reconstruction.
- ▶ Laborer Rate-
 - 1) Removal of lead paint from any surface *NOT* to be repainted.
 - 2) Where removal is on a *TOTAL* Demolition project only.

⇒LABORERS:

- ▶ Acetylene burners, asphalt rakers, chain saw operators, concrete and power buggy operator, concrete saw operator, fence and guard rail erector, hand operated concrete vibrator operator, mason tenders, pipelayers (installation of water, storm drainage or sewage lines outside of the building line with P6, P7 license), pneumatic drill operator, pneumatic gas and electric drill operator, powermen and wagon drill operator, air track operator, block paver, curb setters, blasters, concrete spreaders.

⇒PAINTERS:

- ▶ Maintenance, preparation, cleaning, blasting (water and sand, etc.), painting or application of any protective coatings of every description on all bridges and appurtenances of highways, roadways, and railroads. Painting, decorating, hardwood finishing, paper hanging, sign writing, scenic art work and drywall finishing for any and all types of building and residential work.

⇒PLUMBERS AND PIPEFITTERS:

- ▶ Installation, repair, replacement, alteration or maintenance of all plumbing, heating, cooling and piping. ***License required per Connecticut General Statutes: P-1,2,6,7,8,9 J-1,2,3,4 SP-1,2. S-1,2,3,4,5,6,7,8 B-1,2,3,4 D-1,2,3,4.**

⇒POWER EQUIPMENT OPERATORS:

- ▶ Operates several types of power construction equipment such as compressors, pumps, hoists, derricks, cranes, shovels, tractors, scrapers or motor graders, etc. Repairs and maintains equipment. ***License required, crane operators only, per Connecticut General Statutes.**

⇒ROOFERS:

- ▶ Preparation of surface, tear-off and/or removal of any type of roofing, and/or clean-up of any areas where a roof is to be relaid.

⇒SHEET METAL WORKER:

- ▶ Fabrication, handling, assembling, erecting, altering, repairing, etc. of coated metal material panels and composite metal material panels when used on building exteriors and interiors as soffits, facia, louvers, partitions, wall panel siding, canopies, cornice, column covers, awnings, beam covers, cladding, sun shades, lighting troughs, spires, ornamental roofing, metal ceilings, mansards, copings, ornamental and ventilation hoods, vertical and horizontal siding panels, trim, etc. The sheet metal classification also applies to the vast variety of coated metal material panels and composite metal material panels that have evolved over the years as an alternative to conventional ferrous and non-ferrous metals like steel, iron, tin, copper, brass, bronze, aluminum, etc. Insulated metal and insulated composite panels are still installed by the Iron Worker. Fabrication, handling, assembling, erecting, altering, repairing, etc. of architectural metal roof, standing seam roof, composite metal roof, metal and composite bathroom/toilet partitions, aluminum gutters, metal and composite lockers and shelving, kitchen equipment, and walk-in coolers.

⇒SPRINKLER FITTERS:

Installation, alteration, maintenance and repair of fire protection sprinkler systems. ***License required per Connecticut General Statutes: F-1,2,3,4.**

⇒TILE, MARBLE AND TERRAZZO FINISHERS:

Assists and tends the tile setter, marble mason and terrazzo worker in the performance of their duties.

⇒TRUCK DRIVERS:

- ▶ Truck Drivers delivering asphalt are covered under prevailing wage while on the site and directly involved in the paving operation.
- ▶ Material men and deliverymen are not covered under prevailing wage as long as they are not directly involved in the construction process. If, they unload the material, they would then be covered by prevailing wage for the classification they are performing work in: laborer, equipment operator, etc.
- ▶ Hauling material off site is not covered provided they are not dumping it at a location outlined above.
- ▶ Driving a truck on site and moving equipment or materials on site would be considered covered work, as this is part of the construction process.

CONNECTICUT DEPARTMENT OF LABOR
Wage and Workplace Standards Division

FOOTNOTES

Please Note: If the "Benefits" listed on the schedule for the following occupations includes a letter(s) (+ a or + a+b for instance), refer to the information below.

Benefits to be paid at the appropriate prevailing wage rate for the listed occupation.

If the "Benefits" section for the occupation lists only a dollar amount, disregard the information below.

Bricklayers, Cement Masons, Cement Finishers, Plasters, Stone Masons
(Building Construction)

(Residential- Hartford, Middlesex, New Haven, New London and Tolland Counties)

a. Paid Holiday: Employees shall receive 4 hours for Christmas Eve holiday provided the employee works the regularly scheduled day before and after the holiday. Employees may schedule work on Christmas Eve and employees shall receive pay for actual hours worked in addition to holiday pay.

Bricklayer (Residential- Fairfield County)

a. Paid Holiday: If an employee works on Christmas Eve until noon he shall be paid for 8 hours.

Electricians

Fairfield County: West of the Five Mile River in Norwalk

a. \$2.00 per hour not to exceed \$14.00 per day.

Elevator Constructors: Mechanics

- a. Paid Holidays: New Year's Day, Memorial Day, Independence Day, Labor Day, Thanksgiving Day, Christmas Day, plus the Friday after Thanksgiving.
- b. Vacation: Employer contributes 8% of basic hourly rate for 5 years or more of service or 6% of basic hourly rate for 6 months to 5 years of service as vacation pay credit.

Glaziers

- a. Paid Holidays: Labor Day and Christmas Day.

Power Equipment Operators

(Heavy and Highway Construction & Building Construction)

- a. Paid Holidays: New Year's Day, Good Friday, Memorial day, Independence Day, Labor Day, Thanksgiving Day and Christmas Day, provided the employee works 3 days during the week in which the holiday falls, if scheduled, and if scheduled, the working day before and the working day after the holiday. Holidays falling on Saturday may be observed on Saturday, or if the employer so elects, on the preceding Friday.

Ironworkers

- a. Paid Holiday: Labor Day provided employee has been on the payroll for the 5 consecutive workdays prior to Labor Day.

Laborers (Tunnel Construction)

- a. Paid Holidays: New Year's Day, Memorial Day, Independence Day, Labor Day, Thanksgiving Day and Christmas Day. No employee shall be eligible for holiday pay when he fails, without cause, to work the regular workday preceding the holiday or the regular workday following the holiday.

Roofers

- a. Paid Holidays: July 4th, Labor Day, and Christmas Day provided the employee is employed 15 days prior to the holiday.

Sprinkler Fitters

- a. Paid Holidays: Memorial Day, July 4th, Labor Day, Thanksgiving Day and Christmas Day, provided the employee has been in the employment of a contractor 20 working days prior to any such paid holiday.

Truck Drivers

(Heavy and Highway Construction & Building Construction)

- a. Paid Holidays: New Year's Day, Memorial Day, Independence Day, Labor Day, Thanksgiving Day, Christmas day, and Good Friday, provided the employee has at least 31 days service and works the last scheduled day before and the first scheduled day after the holiday.

EXHIBIT H

To

**REFURBISHMENT OF BELT CONVEYORS CV-123/223
AT THE
MID-CONNECTICUT WASTE PROCESSING FACILITY
AGREEMENT**

SCHEDULE OF PREVAILING WAGES

Project: Refurbishment Of Belt Conveyor CV-123/223 At The Mid-Connecticut Waste Processing Facility

**Minimum Rates and Classifications
for Building Construction**

B 11563

**Connecticut Department of Labor
Wage and Workplace Standards Division**

By virtue of the authority vested in the Labor Commissioner under provisions of Section 31-53 of the General Statutes of Connecticut, as amended, the following are declared to be the prevailing rates and welfare payments and will apply only where the contract is advertised for bid within 20 days of the date on which the rates are established. Any contractor or subcontractor not obligated by agreement to pay to the welfare and pension fund shall pay this amount to each employee as part of his/her hourly wages.

Project Number FY09-0P-009

Project Town Hartford

Project: Refurbishment Of Belt Conveyor CV-123/223 At The Mid-Connecticut Waste Processing Facility

CLASSIFICATION

Hourly Rate

Benefits

1a) Asbestos Worker/Insulator (Includes application of insulating materials, protective coverings, coatings, & finishes to all types of mechanical systems; application of firestopping material for wall openings & penetrations in walls, floors, ceilings.

34.21

19.81

1b) Asbestos/Toxic Waste Removal Laborers: Asbestos removal and encapsulation (except its removal from mechanical systems which are not to be scrapped), toxic waste removers, blasters.**See Laborers Group 7**

1c) Hazardous Material Handler: Includes preparation, wetting, stripping, removal, scrapping, vacuuming, bagging and disposing of all insulation materials, whether they contain asbestos or not, from mechanical systems.

20.50

10.30

2) Boilermaker

32.73

8.72 + 33%

3a) Bricklayer, Cement Mason, Cement Finishers, Plasterers, Stone Masons

31.60

18.98 + a

3b) Tile Setter

30.78

16.98

As of: Tuesday, November 18, 2008

Project: Refurbishment Of Belt Conveyor CV-123/223 At The Mid-Connecticut Waste Processing Facility

3c) Terrazzo Workers, Marble Setters 30.91 19.12

3d) Tile, Marble & Terrazzo Finishers 24.90 14.78

-----LABORERS-----

4) Group 1: Laborers, carpenter tenders, wrecking laborers, fire watchers. 23.25 14.00

4a) Group 2: Mortar mixers, plaster tenders, power buggy operators, powdermen, fireproofers/mixer/nozzleman. 23.50 14.00

4b) Group 3: Jackhammer operators, mason tenders. 23.75 14.00

4c) **Group 4: Pipelayers (Installation of water, storm drainage or sewage lines outside of the building line with P6, P7 license) [If using this classification call the Labor Department for clarification] 24.10 14.00

4d) Group 5: Air track operators, Sand blasters. 24.00 14.00

4e) Group 6: Nuclear toxic waste removers, blasters. 26.25 14.00

4f) Group 7: Asbestos removal and encapsulation (except it's removal from mechanical systems which are not to be scrapped). 24.25 14.00

As of: Tuesday, November 18, 2008

Project: Refurbishment Of Belt Conveyor CV-123/223 At The Mid-Connecticut Waste Processing Facility

4g) Group 8: Bottom men on open air caisson, cylindrical work and boring crew.	23.75	14.00
4h) Group 9: Top men on open air caisson, cylindrical work and boring crew.	23.25	14.00
5) Carpenter, Acoustical Tile Worker, Concrete Form-Wood Builder, Floor Covering (Including Drywall Hanging), Modular-Furniture Systems Installers, Lathers, Piledrivers, Resilient Floor Layers.	27.90	16.96
5a) Millwrights	28.65	16.96
6) Electrical Worker, Cable Splicer (electric) (Trade License required: E1,2 L-5,6 C-5,6 T-1,2 L-1,2 V-1,2,7,8,9)	34.40	18.57
7a) Elevator Mechanic (Trade License required: R-1,2,5,6)	41.34	16.285+a+b
8) Glazier (Trade License required: FG-1,2)	31.43	14.00 + a
9) Ironworker, Ornamental, Reinforcing, Structural, and Precast Concrete Erection	31.80	23.18 + a
----OPERATORS----		
Group 1: Crane handling or erecting structural steel or stone, hoisting engineer 2 drums or over, front end loader (7 cubic yards or over); work boat 26 ft. and over.	33.05	16.90 + a

As of: Tuesday, November 18, 2008

Project: Refurbishment Of Belt Conveyor CV-123/223 At The Mid-Connecticut Waste Processing Facility		
Group 2: Cranes (100 ton rate capacity and over); Excavator over 2 cubic yards; Piledriver (\$3.00 premium when operator controls hammer)	32.73	16.90 + a
Group 3: Excavator; Cranes (under 100 ton rated capacity), Gradall; Master Mechanic; Hoisting Engineer (all types of equipment where a drum and cable are used to hoist or drag material regardless of motive power of operation), Rubber Tire Excavator (Drott-1085	31.99	16.90 + a
Group 4: Trenching Machines; Lighter Derrick; Concrete Finishing Machine; CMI Machine or Similar; Koehring Loader (Skooper)	31.60	16.90 + a
Group 5: Specialty Railroad Equipment; Asphalt Spreader; Asphalt Reclaiming Machine; Line Grinder; Concrete Pumps; Drills with Self Contained Power Units; Boring Machine; Post Hole Digger; Auger; Pounder; Well Digger; Milling Machine (over 24" Mandrell)	31.01	16.90 + a
Group 5 continued: Side Boom; Combination Hoe and Loader; Directional Driller.	31.01	16.90 + a
Group 6: Front End Loader (3 up to 7 cubic yards); Bulldozer (rough grade dozer).	30.70	16.90 + a
Group 7: Asphalt roller, concrete saws and cutters (ride on types), vermeer concrete cutter, Stump Grinder; Scraper; Snooper; Skidder; Milling Machine (24" and under Mandrell).	30.36	16.90 + a
Group 8: Mechanic, grease truck operator, hydroblaster; barrier mover; power stone spreader; welding; work boat under 26 ft.; transfer machine.	29.96	16.90 + a
Group 9: Front end loader (under 3 cubic yards), skid steer loader regardless of attachments, (Bobcat or Similar): forklift, power chipper; landscape equipment (including Hydroseeder).	29.53	16.90 + a
Group 10: Vibratory hammer; ice machine; diesel and air, hammer, etc.	27.49	16.90 + a

As of: Tuesday, November 18, 2008

Project: Refurbishment Of Belt Conveyor CV-123/223 At The Mid-Connecticut Waste Processing Facility		
Group 11: Conveyor, earth roller, power pavement breaker (whiphammer), robot demolition equipment.	27.49	16.90 + a
Group 12: Wellpoint operator.	27.43	16.90 + a
Group 13: Compressor battery operator.	26.85	16.90 + a
Group 14: Elevator operator; tow motor operator (solid tire no rough terrain).	25.71	16.90 + a
Group 15: Generator Operator; Compressor Operator; Pump Operator; Welding Machine Operator; Heater Operator.	25.30	16.90 + a
Group 16: Maintenance engineer.	24.65	16.90 + a
Group 17: Portable asphalt plant operator; portable crusher plant operator; portable concrete plant operator.	28.96	16.90 + a
Group 18: Power safety boat; vacuum truck; zim mixer; sweeper; (Minimum for any job requiring a CDL license).	26.54	16.90 + a
-----PAINTERS (Including Drywall Finishing)-----		
10a) Brush, Roller	27.87	14.00

As of: Tuesday, November 18, 2008

Project: Refurbishment Of Belt Conveyor CV-123/223 At The Mid-Connecticut Waste Processing Facility

10b) Taper	28.62	14.00
10c) Paperhanger	28.37	14.00
10d) Red Label	28.37	14.00
10e) Blast and Spray	30.87	14.00
10f) Tanks, Tower, Swingstage	29.87	14.00
11) Plumber P-1,2,6,7,8,9 J-1,2,3,4 SP-1,2)	(Trade License required: 35.37	19.71
12) Post Digger, Well Digger, Pile Testing Machine	25.25	9.05 + a
13) Roofer (composition)	30.30	13.61
14) Roofer (slate & tile)	30.80	13.61
15) Sheetmetal Worker (Trade License required for HVAC and Ductwork: SM-1,SM-2,SM-3,SM-4,SM-5,SM-6)	30.57	24.50

As of: Tuesday, November 18, 2008

Project: Refurbishment Of Belt Conveyor CV-123/223 At The Mid-Connecticut Waste Processing Facility

16) Pipefitter (Including HVAC work) (Trade License required: S-1,2,3,4,5,6,7,8 B-1,2,3,4 D-1,2,3,4, G-1, G-2, G-8 & G-9)	35.37	19.71
---	-------	-------

-----TRUCK DRIVERS-----

17a) 2 Axle	26.18	12.47 + a
17b) 3 Axle, 2 Axle Ready Mix	26.28	12.47 + a
17c) 3 Axle Ready Mix	26.33	12.47 + a
17d) 4 Axle, Heavy Duty Trailer up to 40 tons	26.38	12.47 + a
17e) 4 Axle Ready Mix	26.43	12.47 + a
17f) Heavy Duty Trailer (40 Tons and Over)	26.63	12.47 + a
17g) Specialized Earth Moving Equipment (Other Than Conventional Type on-the-Road Trucks and Semi-Trailers, Including Euclids)	26.43	12.47 + a
18) Sprinkler Fitter (Trade License required: F-1,2,3,4)	38.35	15.65 + a

As of: Tuesday, November 18, 2008

Project: Refurbishment Of Belt Conveyor CV-123/223 At The Mid-Connecticut Waste Processing Facility

Welders: Rate for craft to which welding is incidental.

**Note: Hazardous waste removal work receives additional \$1.25 per hour for truck drivers.*

***Note: Hazardous waste premium \$3.00 per hour over classified rate*

- Crane with 150 ft. boom (including jib) - \$1.50 extra
- Crane with 200 ft. boom (including jib) - \$2.50 extra
- Crane with 250 ft. boom (including jib) - \$5.00 extra
- Crane with 300 ft. boom (including jib) - \$7.00 extra
- Crane with 400 ft. boom (including jib) - \$10.00 extra

All classifications that indicate a percentage of the fringe benefits must be calculated at the percentage rate times the "base hourly rate".

Apprentices duly registered under the Commissioner of Labor's regulations on "Work Training Standards for Apprenticeship and Training Programs" Section 31-51-d-1 to 12, are allowed to be paid the appropriate percentage of the prevailing journeymen hourly base and the full fringe benefit rate, providing the work site ratio shall not be less than one full-time journeyman instructing and supervising the work of each apprentice in a specific trade.

The Prevailing wage rates applicable to this project are subject to annual adjustments each July 1st for the duration of the project.

Each contractor shall pay the annual adjusted prevailing wage rate that is in effect each July 1st, as posted by the Department of Labor.

It is the contractor's responsibility to obtain the annual adjusted prevailing wage rate increases directly from the Department of Labor's website.

The annual adjustments will be posted on the Department of Labor's Web page: www.ct.gov/dol

The Department of Labor will continue to issue the initial prevailing wage rate schedule to the Contracting Agency for the project.

All subsequent annual adjustments will be posted on our Web Site for contractor access.

As of: Tuesday, November 18, 2008

Project: Refurbishment Of Belt Conveyor CV-123/223 At The Mid-Connecticut Waste Processing Facility

Effective October 1, 2005 - Public Act 05-50: any person performing the work of any mechanic, laborer, or worker shall be paid prevailing wage

All Person who perform work ON SITE must be paid prevailing wage for the appropriate mechanic, laborer, or worker classification.

All certified payrolls must list the hours worked and wages paid to All Persons who perform work ON SITE regardless of their ownership i.e.: (Owners, Corporate Officers, LLC Members, Independent Contractors, et. al)

Reporting and payment of wages is required regardless of any contractual relationship alleged to exist between the contractor and such person.

Please direct any questions which you may have pertaining to classification of work and payment of prevailing wages to the Wage and Workplace Standards Division, telephone (860)263-6790.

As of: Tuesday, November 18, 2008

EXHIBIT I

To

**REFURBISHMENT OF BELT CONVEYORS CV-123/223
AT THE
MID-CONNECTICUT WASTE PROCESSING FACILITY
AGREEMENT**

**SEEC FORM 11
NOTICE TO EXECUTIVE BRANCH STATE
CONTRACTORS AND PROSPECTIVE STATE
CONTRACTORS OF CAMPAIGN CONTRIBUTION
AND SOLICITATION BAN**

SEEC FORM 11

NOTICE TO EXECUTIVE BRANCH STATE CONTRACTORS AND PROSPECTIVE STATE CONTRACTORS OF CAMPAIGN CONTRIBUTION AND SOLICITATION BAN

This notice is provided under the authority of Connecticut General Statutes 9-612(g)(2), as amended by P.A. 07-1, and is for the purpose of informing state contractors and prospective state contractors of the following law (italicized words are defined on the following page):

Campaign Contribution and Solicitation Ban

No state contractor, prospective state contractor, principal of a state contractor or principal of a prospective state contractor, with regard to a state contract or state contract solicitation with or from a state agency in the executive branch or a quasi-public agency or a holder, or principal of a holder of a valid prequalification certificate, shall make a contribution to, or solicit contributions on behalf of (i) an exploratory committee or candidate committee established by a candidate for nomination or election to the office of Governor, Lieutenant Governor, Attorney General, State Comptroller, Secretary of the State or State Treasurer, (ii) a political committee authorized to make contributions or expenditures to or for the benefit of such candidates, or (iii) a party committee;

In addition, no holder or principal of a holder of a valid prequalification certificate, shall make a contribution to, or solicit contributions on behalf of (i) an exploratory committee or candidate committee established by a candidate for nomination or election to the office of State senator or State representative, (ii) a political committee authorized to make contributions or expenditures to or for the benefit of such candidates, or (iii) a party committee.

Duty to Inform

State contractors and prospective state contractors are required to inform their principals of the above prohibitions, as applicable, and the possible penalties and other consequences of any violation thereof.

Penalties for Violations

Contributions or solicitations of contributions made in violation of the above prohibitions may result in the following civil and criminal penalties:

Civil penalties—\$2000 or twice the amount of the prohibited contribution, whichever is greater, against a principal or a contractor. Any state contractor or prospective state contractor which fails to make reasonable efforts to comply with the provisions requiring notice to its principals of these prohibitions and the possible consequences of their violations may also be subject to civil penalties of \$2000 or twice the amount of the prohibited contributions made by their principals.

Criminal penalties—Any knowing and willful violation of the prohibition is a Class D felony, which may subject the violator to imprisonment of not more than 5 years, or \$5000 in fines, or both.

Contract Consequences

Contributions made or solicited in violation of the above prohibitions may result, in the case of a state contractor, in the contract being voided.

Contributions made or solicited in violation of the above prohibitions, in the case of a prospective state contractor, shall result in the contract described in the state contract solicitation not being awarded to the prospective state contractor, unless the State Elections Enforcement Commission determines that mitigating circumstances exist concerning such violation.

The State will not award any other state contract to anyone found in violation of the above prohibitions for a period of one year after the election for which such contribution is made or solicited, unless the State Elections Enforcement Commission determines that mitigating circumstances exist concerning such violation.

Additional information and the entire text of P.A 07-1 may be found on the website of the State Elections Enforcement Commission, www.ct.gov/seec. Click on the link to "State Contractor Contribution Ban."

Definitions:

"State contractor" means a person, business entity or nonprofit organization that enters into a state contract. Such person, business entity or nonprofit organization shall be deemed to be a state contractor until December thirty-first of the year in which such contract terminates. "State contractor" does not include a municipality or any other political subdivision of the state, including any entities or associations duly created by the municipality or political subdivision exclusively amongst themselves to further any purpose authorized by statute or charter, or an employee in the executive or legislative branch of state government or a quasi-public agency, whether in the classified or unclassified service and full or part-time, and only in such person's capacity as a state or quasi-public agency employee.

"Prospective state contractor" means a person, business entity or nonprofit organization that (i) submits a response to a state contract solicitation by the state, a state agency or a quasi-public agency, or a proposal in response to a request for proposals by the state, a state agency or a quasi-public agency, until the contract has been entered into, or (ii) holds a valid prequalification certificate issued by the Commissioner of Administrative Services under section 4a-100. "Prospective state contractor" does not include a municipality or any other political subdivision of the state, including any entities or associations duly created by the municipality or political subdivision exclusively amongst themselves to further any purpose authorized by statute or charter, or an employee in the executive or legislative branch of state government or a quasi-public agency, whether in the classified or unclassified service and full or part-time, and only in such person's capacity as a state or quasi-public agency employee.

"Principal of a state contractor or prospective state contractor" means (i) any individual who is a member of the board of directors of, or has an ownership interest of five per cent or more in, a state contractor or prospective state contractor, which is a business entity, except for an individual who is a member of the board of directors of a nonprofit organization, (ii) an individual who is employed by a state contractor or prospective state contractor, which is a business entity, as president, treasurer or executive vice president, (iii) an individual who is the chief executive officer of a state contractor or prospective state contractor, which is not a business entity, or if a state contractor or prospective state contractor has no such officer, then the officer who duly possesses comparable powers and duties, (iv) an officer or an employee of any state contractor or prospective state contractor who has *managerial or discretionary responsibilities with respect to a state contract*, (v) the spouse or a *dependent child* who is eighteen years of age or older of an individual described in this subparagraph, or (vi) a political committee established or controlled by an individual described in this subparagraph or the business entity or nonprofit organization that is the state contractor or prospective state contractor.

"State contract" means an agreement or contract with the state or any state agency or any quasi-public agency, let through a procurement process or otherwise, having a value of fifty thousand dollars or more, or a combination or series of such agreements or contracts having a value of one hundred thousand dollars or more in a calendar year, for (i) the rendition of services, (ii) the furnishing of any goods, material, supplies, equipment or any items of any kind, (iii) the construction, alteration or repair of any public building or public work, (iv) the acquisition, sale or lease of any land or building, (v) a licensing arrangement, or (vi) a grant, loan or loan guarantee. "State contract" does not include any agreement or contract with the state, any state agency or any quasi-public agency that is exclusively federally funded, an education loan or a loan to an individual for other than commercial purposes.

"State contract solicitation" means a request by a state agency or quasi-public agency, in whatever form issued, including, but not limited to, an invitation to bid, request for proposals, request for information or request for quotes, inviting bids, quotes or other types of submittals, through a competitive procurement process or another process authorized by law waiving competitive procurement.

"Managerial or discretionary responsibilities with respect to a state contract" means having direct, extensive and substantive responsibilities with respect to the negotiation of the state contract and not peripheral, clerical or ministerial responsibilities.

"Dependent child" means a child residing in an individual's household who may legally be claimed as a dependent on the federal income tax of such individual.

"Solicit" means (A) requesting that a contribution be made, (B) participating in any fund-raising activities for a candidate committee, exploratory committee, political committee or party committee, including, but not limited to, forwarding tickets to potential contributors, receiving contributions for transmission to any such committee or bundling contributions, (C) serving as chairperson, treasurer or deputy treasurer of any such committee, or (D) establishing a political committee for the sole purpose of soliciting or receiving contributions for any committee. Solicit does not include: (i) making a contribution that is otherwise permitted by Chapter 155 of the Connecticut General Statutes; (ii) informing any person of a position taken by a candidate for public office or a public official, (iii) notifying the person of any activities of, or contact information for, any candidate for public office; or (iv) serving as a member in any party committee or as an officer of such committee that is not otherwise prohibited in this section.

EXHIBIT J

To

**REFURBISHMENT OF BELT CONVEYORS CV-123/223
AT THE
MID-CONNECTICUT WASTE PROCESSING FACILITY
AGREEMENT**

**CERTIFICATION CONCERNING
NONDISCRIMINATION**

CERTIFICATION CONCERNING NONDISCRIMINATION

[The successful bidder's Certification Concerning Nondiscrimination that was submitted with the successful bidder's bid will be added by CRRA.]

EXHIBIT K

To

**REFURBISHMENT OF BELT CONVEYORS CV-123/223
AT THE
MID-CONNECTICUT WASTE PROCESSING FACILITY
AGREEMENT**

**CONTRACTOR'S CERTIFICATION CONCERNING
GIFTS**

CONTRACTOR'S CERTIFICATION CONCERNING GIFTS

[The successful bidder's Contractor's Certification Concerning Gifts that was submitted with the successful bidder's Notice Of Award will be added by CRRA.]

EXHIBIT L

To

**REFURBISHMENT OF BELT CONVEYORS CV-123/223
AT THE
MID-CONNECTICUT WASTE PROCESSING FACILITY
AGREEMENT**

**CRRA PRESIDENT'S CERTIFICATION
CONCERNING GIFTS**



**PRESIDENT'S CERTIFICATION
CONCERNING GIFTS**

**REFURBISHMENT OF BELT CONVEYORS CV-123/223
AT THE
MID-CONNECTICUT WASTE PROCESSING FACILITY
Awarded To**

[Name of Contractor/Consultant]

(This CERTIFICATION is to be signed by the President of CRRA
at the time the Agreement is executed by him/her.)

By submission of this Certification, the President of the Connecticut Resources Recovery Authority ("CRRA") hereby certifies that the selection of the most qualified or highest ranked person, firm or corporation for the Refurbishment of Belt Conveyors CV-123/223 At The Mid-Connecticut Waste Processing Facility Agreement was not the result of collusion, the giving of a gift or the promise of a gift, compensation, fraud or inappropriate influence from any person.

Signature: _____

Name: Thomas D. Kirk

Title: President

State Of: Connecticut

County Of: Hartford

Thomas D. Kirk, being fully sworn, deposes and says that he is the President of the Connecticut Resources Recovery Authority, that he has read the forgoing statement concerning collusion, the giving of gifts or the promise of gifts, compensation, fraud or inappropriate influence and, under the penalty of perjury, certifies that each and every part of said statement is true.

Sworn to before me this _____ day of _____ 200__

Notary Public/Commissioner of the Superior Court