



**REQUEST FOR BIDS
FOR
AIR EMISSIONS TESTING
AT THE
MID-CONNECTICUT POWER BLOCK FACILITY
(RFB Number 12-EN-001)**

BID DUE DATE – JUNE 1, 2011

**Connecticut Resources Recovery Authority
100 Constitution Plaza, 6th Floor
Hartford, Connecticut 06103-1722**

May 2, 2011

REQUEST FOR BIDS
For
AIR EMISSIONS TESTING
AT THE
MID-CONNECTICUT POWER BLOCK FACILITY
(RFB Number 12-EN-001)

Connecticut Resources Recovery Authority
100 Constitution Plaza, 6th Floor
Hartford, Connecticut 06103-1722

TABLE OF CONTENTS

1. Notice To Contractors – Invitation To Bid
2. Instructions To Bidders
3. Bid Bond Form
4. Bid Form
5. Bid Price And Payment Rate Schedule Form
6. Business Information Form
7. Personnel Background And Experience Form
8. References Form
9. Subcontractor Identification Form
10. Questionnaire Concerning Affirmative Action, Small Business Contractors And Occupational Health And Safety
11. Affidavit Concerning Nondiscrimination
12. Background Questionnaire
13. SEEC Form 11, Notice To Executive Branch State Contractors And Prospective State Contractors Of Campaign Contribution And Solicitation Ban
14. Notice Of Award
 - A. Contractor's Certification Concerning Gifts [To be executed by successful bidder]
 - B. Affidavit Concerning Consulting Fees [To be executed by successful bidder]
15. Agreement For Air Emissions Testing At The Mid-Connecticut Power Block Facility
 - A. Scope Of Services
 - B. Compensation Schedule
 - C. CRRA's Travel And Expense Reporting Policy And Procedure
 - D. Monthly Bill Format
 - E. SEEC Form 11, Notice To Executive Branch State Contractors And Prospective State Contractors Of Campaign Contribution And Solicitation Ban
 - F. Affidavit Concerning Nondiscrimination
 - G. Affidavit Concerning Consulting Fees
 - H. Contractor's Certification Concerning Gifts
 - I. CRRA President's Certification Concerning Gifts

**REQUEST FOR BIDS
FOR
AIR EMISSIONS TESTING
AT THE
MID-CONNECTICUT POWER BLOCK FACILITY**

SECTION 1

**NOTICE TO CONTRACTORS -
INVITATION TO BID**

CONNECTICUT RESOURCES RECOVERY AUTHORITY

NOTICE TO CONTRACTORS – INVITATION TO BID

The Connecticut Resources Recovery Authority (“CRRA”) is seeking bids from qualified contractors to furnish all materials, labor, equipment and incidentals to perform the 2012, 2013 and 2014 annual air emissions performance tests at the Power Block Facility (part of the Mid-Connecticut Resource Recovery Facility) and to perform other work incidental thereto. The air emissions performance test must be performed in accordance with Section 22a-174-38 of the *Regulations of Connecticut State Agencies*. The Power Block Facility is located at Gate 20, Reserve Road (South Meadows Station), Hartford, Connecticut 06114.

Request For Bid (“RFB”) package documents may be obtained on the World Wide Web at <http://www.crra.org> under the “Business Opportunities” page beginning **Monday, May 2, 2011**. The documents will also be available Monday through Friday, from 8:30 a.m. to 5:00 p.m. at the offices of CRRA, 100 Constitution Plaza, 6th Floor, Hartford, Connecticut 06103-1722, beginning on the same date. Anyone intending to pick up the documents at CRRA’s offices must contact Ronald Gingerich (860-757-7703) at least 24 hours in advance. There is a charge of \$25.00 for anyone picking up the documents at CRRA’s office. Payment should be made by check payable to “Connecticut Resources Recovery Authority.”

There will be a mandatory pre-bid conference and tour of the site for all prospective bidders. **The mandatory pre-bid conference and tour will meet at the Covanta Conference Room, Reserve Road, Gate 20, Hartford, Connecticut 06114, at 10:00 a.m., Wednesday, May 11, 2011.** Any prospective bidder intending to participate in the tour must contact Ronald Gingerich by telephone (860-757-7703) or by e-mail (rgingerich@crra.org) by 3:00 p.m., Tuesday, May 10, 2011.

Sealed bids will be received at the offices of CRRA, 100 Constitution Plaza, 6th Floor, Hartford, Connecticut 06103-1722 no later than 3:00 p.m., Eastern Time, on Wednesday, June 1, 2011. Bids received after the time and date set forth above shall be rejected. All bids shall remain open for ninety (90) days after the bid due date.

Bids will be opened at CRRA’s convenience on or after the bid due date.

Note that all information submitted by bidder is subject to the Freedom of Information Act.

All questions regarding this RFB must be submitted **in writing** to Ronald Gingerich, by e-mail (rgingerich@crra.org), by fax (860-757-7742), or by correspondence (CRRA, 100 Constitution Plaza, 6th Floor, Hartford, Connecticut 06103) no later than **3:00 p.m., Wednesday, May 18, 2011**. Subject to the discretion of CRRA, CRRA may decide to provide written responses to contractors no later than Tuesday, May 24, 2011. Any contractor considering submitting a bid is prohibited from having any ex-parte communications with any CRRA staff member or CRRA Board member except Mr. Gingerich.

**REQUEST FOR BIDS
FOR
AIR EMISSIONS TESTING
AT THE
MID-CONNECTICUT POWER BLOCK FACILITY**

**SECTION 2
INSTRUCTIONS TO BIDDERS**

INSTRUCTIONS TO BIDDERS

AIR EMISSIONS TESTING AT THE MID-CONNECTICUT POWER BLOCK FACILITY

CONTENTS

1.	Introduction.....	1
2.	RFB Projected Timeline	2
3.	Definitions.....	2
4.	Communications With CRRA Staff and Board Members.....	4
5.	Reserved Rights.....	4
6.	Scope Of Services.....	4
7.	Availability of RFB Package Documents.....	5
8.	Mandatory Pre-Bid Conference And Site Tour	5
9.	Addenda And Interpretations	6
10.	Bid Submittal Procedures.....	7
11.	Period Bids Shall Remain Open.....	7
12.	Non-Negotiability Of The Agreement	7
13.	Modification/Withdrawal Of A Bid.....	7
14.	Bid Security	7
15.	Bid Contents.....	8
16.	Bid Opening.....	10
17.	Bid Evaluation	10
18.	Contract Award.....	12
19.	Contractor's Certification Concerning Gifts.....	12
20.	Affidavit Concerning Consulting Fees.....	12
21.	Bidder's Qualifications.....	12
22.	Bid Preparation And Other Costs.....	12

1. Introduction

The Connecticut Resources Recovery Authority (“CRRA”) is a quasi-public entity of the State of Connecticut that is responsible for implementing the State Solid Waste Management Plan and is currently providing solid waste disposal and recycling services to more than 100 municipalities in the state. CRRA has developed, constructed and now operates an integrated system of two resource recovery facilities, two regional recycling centers, and four transfer stations. At present, CRRA accepts more than 60% of the municipal solid waste generated in the State. These facilities are operated by entities that are under contract with CRRA.

One of CRRA’s facilities is the Mid-Connecticut Resource Recovery Facility (“RRF”), which is a waste-to-energy facility. The Mid-Connecticut RRF includes the Power Block Facility (“PBF”), which is the facility where Refuse Derived Fuel (“RDF”) is combusted to

produce steam. The PBF uses three combustors, each having its own flue gas treatment equipment. Each of the three combustors is rated to consume up to 28.15 tons per hour of RDF and to produce up to 231,000 pounds per hour of steam.

The PBF is located at 1 Reserve Road, Gate 20, Hartford, Connecticut 06114. The PBF is currently operated by Covanta Energy (“Covanta”) under contract to CRRA. Effective June 1, 2012, operation of the PBF will be transferred to NAES Corporation (“NAES”) under contract to CRRA.

CRRA is seeking bids from qualified contractors to furnish all labor, incidentals and miscellaneous materials thereto to perform the 2012, 2013 and 2014 annual air emissions performance tests at the PBF.

2. RFB Projected Timeline

The following is the projected timeline for the RFB process:

ITEM	DATE/TIME
RFB Documents Available	Monday, May 2, 2011
Pre-Bid Conference and Site Tour	10:00 a.m., Wednesday, May 11, 2011
Deadline for Written Questions	3:00 p.m., Wednesday, May 18, 2011
Response to Written Questions	No later than Tuesday, May 24, 2011
Bids Due at CRRA	3:00 p.m. Wednesday, June 1, 2011
Notice Of Award Issued	Friday, July 1, 2011

CRRA reserves the right at its sole and absolute discretion to extend any of the actual or proposed dates in the above Projected Timeline

3. Definitions

As used in this Instructions To Bidders and in other Contract Documents (as defined herein), the following terms shall have the meanings as set forth below:

- (a) **Addenda:** Written or graphic documents issued prior to the bid due date that clarify, correct or change any or all of the Contract Documents.
- (b) **Contract Documents:**
 - (1) Agreement For Air Emissions Testing At The Mid-Connecticut Power Block Facility (the “Agreement”);
 - (2) RFB Package Documents (defined in (g) below);

- (3) Addenda;
 - (4) Successful bidder's bid (including all documentation attached to or accompanying such bid, all other documentation submitted in connection with such bid, and all post-bid documentation submitted prior to the Notice Of Award);
 - (5) Notice Of Award; and
 - (6) Any written amendments to the Agreement.
- (c) **Laws And Regulations:** Any and all applicable laws, rules, regulations, ordinances, codes, orders and permits of any and all federal, state and local governmental and quasi-governmental bodies, agencies, authorities and courts having jurisdiction.
- (d) **Notice Of Award:** Written notification from CRRA to the apparent successful bidder that states that CRRA has accepted such bidder's bid and sets forth the remaining conditions that must be fulfilled by such bidder before CRRA executes the Agreement.
- (e) **Project:** The provision of air emissions testing services at the Mid-Connecticut PBF, in accordance with the Contract Documents.
- (f) **Property:** The certain parcel of real property located at Reserve Road, Gate 20, Hartford, Connecticut 06114, upon which property CRRA operates the Mid-Connecticut PBF.
- (g) **RFB Package Documents:**
- (1) Notice To Contractors – Invitation To Bid;
 - (2) Instructions To Bidders;
 - (3) Bid Security (Bid Bond Form);
 - (4) Bid Form;
 - (5) Bid Price And Payment Rate Schedule Form;
 - (6) Business Information Form;
 - (7) Personnel Background And Experience Form;
 - (8) References Form;
 - (9) Subcontractor Identification Form;
 - (10) Questionnaire Concerning Affirmative Action, Small Business Contractors And Occupational Health And Safety;
 - (11) Affidavit Concerning Nondiscrimination;
 - (12) Bidder's Background Questionnaire;
 - (13) SEEC Form 11, Notice To Executive Branch State Contractors And Prospective State Contractors Of Campaign Contribution And Solicitation Ban;
 - (14) Notice Of Award, with Contractor Certification Concerning Gifts and the Affidavit Concerning Consulting Fees attached [each to be executed by successful bidder]; and

- (15) Agreement For Air Emissions Testing At The Mid-Connecticut Power Block Facility, including:
 - A. Scope Of Services;
 - B. Compensation Schedule;
 - C. CRRA's Travel And Expense Reporting Policy And Procedure;
 - D. Monthly Bill Format;
 - E. SEEC Form 11, Notice To Executive Branch State Contractors And Prospective State Contractors Of Campaign Contribution And Solicitation Ban;
 - F. Affidavit Concerning Nondiscrimination;
 - G. Affidavit Concerning Consulting Fees;
 - H. Contractor's Certification Concerning Gifts; and
 - I. CRRA President's Certification Concerning Gifts.

- (h) **Site:** Those areas of the Property upon which any of the Services are to be performed, furnished and completed by the successful bidder in accordance with the Contract Documents.

Terms used, but not defined, in this Instructions To Bidders shall have the same respective meanings assigned to such terms in the Agreement.

4. Communications With CRRA Staff and Board Members

Except as otherwise authorized by this Instructions To Bidders, during the period while the RFB process is active (i.e., from the date CRRA issues the RFB until the date the successful bidder accepts the Notice Of Award), contractors contemplating or preparing bids are prohibited from contacting CRRA staff or CRRA Board of Director members in an ex parte manner to discuss the RFB submission process. A contractor's RFB submission shall be rejected if any of the foregoing ex parte communications take place.

5. Reserved Rights

CRRA reserves the following rights at its sole and absolute discretion:

- (a) To reject any or all of the bids, or any part(s) thereof, and/or to waive any informality or informalities in any bid or the RFB process for this Project;
- (b) To republish this RFB after having rejected any or all of the bids; and
- (c) To terminate this RFB process at any time prior to the execution of any Agreement.

6. Scope Of Services

CRRA is seeking bids from qualified contractors to furnish all tools, materials, labor, equipment and incidentals thereto for the 2012, 2013 and 2014 air emissions testing at the PBF (the "Services"). The Services will include, but will not be limited to, the following:

- (a) Preparation of a test protocol and “Intent To Test” documentation acceptable to the Connecticut Department of Environmental Protection (“CTDEP”);
- (b) Mobilization, set-up, emissions testing and demobilization;
- (c) Laboratory testing of all samples; and
- (d) Preparation of a final report acceptable to the CTDEP.

Specific instructions about how the Services are to be performed are included in the Agreement. The Services will be performed in accordance with and as required by the Contract Documents, including but not limited to, the Scope Of Services set forth in **Exhibit A** (the “Scope of Services”) of the Agreement.

7. Availability of RFB Package Documents

Complete sets of the RFB Package Documents may be obtained on the World Wide Web beginning Monday, May 2, 2011:

<http://www.crra.org> under the “Business Opportunities” page; select the “RFB: Air Emissions Testing At The Mid-Connecticut Power Block Facility” link.

The RFB Package Documents are in PDF format. Many of the forms included in the documents are also available for downloading in Microsoft Word format on CRRA’s web site. Prospective bidders can fill the forms out by entering the answers using their computer’s keyboard and mouse. The forms can then be printed and submitted with the bid. CRRA encourages firms to make use of the downloadable Word forms.

The RFB Package Documents are also available Monday through Friday, from 8:30 a.m. to 5:00 p.m. at CRRA’s offices, 100 Constitution Plaza, 6th Floor, Hartford, Connecticut 06103-1722, beginning on the same date. Anyone intending to pick up the documents at CRRA’s offices must contact Ronald Gingerich (860-757-7703) at least 24 hours in advance. There is a charge of \$25.00 for anyone picking up the documents at CRRA’s office. Payment should be made by check payable to “Connecticut Resources Recovery Authority.”

8. Mandatory Pre-Bid Conference And Site Tour

There will be a mandatory pre-bid conference and tour of the Site for all prospective bidders. **The mandatory pre-bid conference and tour will meet at the Covanta Conference Room, Reserve Road, Gate 20, Hartford, Connecticut 06114, at 10:00 a.m., Wednesday, May 11, 2011.** Bids submitted by a bidder who did not attend the mandatory pre-bid conference and site tour shall be rejected. Alternate times for visiting the Site will not be allowed.

Any prospective bidder intending to participate in the tour must contact Ronald Gingerich by telephone (860-757-7703) or by e-mail (rgingerich@crra.org) by 3:00 p.m., Tuesday, May 10, 2011.

Except as otherwise authorized by this Instructions To Bidders, bidders are expressly prohibited from contacting any CRRA personnel regarding this bid solicitation.

9. Addenda And Interpretations

CRRA may issue Addenda to the RFB Package Documents that shall, upon issuance, become part of the RFB Package Documents and binding upon all potential or actual bidders for the Services. Such Addenda may be issued in response to requests for interpretation or clarification received from potential bidders. CRRA reserves the right to not respond to any or all inquiries.

Any request for interpretation or clarification of any documents included in the RFP package documents must be submitted **in writing** to Ronald Gingerich using one of the following methods:

- (a) By e-mail to rgingerich@crra.org;
- (b) By fax to 860-757-7742; or
- (c) By correspondence to CRRA, 100 Constitution Plaza, 6th Floor, Hartford, Connecticut 06103-1722.

To be given consideration, any such written request must be received by CRRA by 3:00 p.m., Wednesday, May 18, 2011.

Addenda, if any, issued prior to the mandatory pre-bid conference and site tour will be posted on CRRA's web site (<http://www.crca.org> on the "Business Opportunities" page under the "RFB: Air Emissions Testing At The Mid-Connecticut Power Block Facility" heading).

Addenda issued after the mandatory pre-bid conference and site tour will be mailed and/or e-mailed to all persons who attended the pre-bid conference and site tour and will be posted on CRRA's web site (<http://www.crca.org> on the "Business Opportunities" page under the "RFB: Air Emissions Testing At The Mid-Connecticut Power Block Facility" heading). Such addenda will be mailed/e-mailed and posted on the web site no later than Tuesday, May 24, 2011.

Failure of any bidder to receive any such Addenda shall not relieve such bidder from any conditions stipulated in such Addenda. Only questions answered or issues addressed by formal written Addenda will be binding. **All oral and other written responses, statements, interpretations or clarifications shall be without legal effect and shall not be binding upon CRRA.**

10. Bid Submittal Procedures

Sealed bids shall be submitted no later than 3:00 p.m., Eastern Time, Wednesday, June 1, 2011 at the offices of CRRA, 100 Constitution Plaza, 6th Floor, Hartford, Connecticut 06103-1722, Attn: Ronald Gingerich. Bids received after the time and date set forth above shall be rejected.

Each bidder must submit one (1) original and two (2) copies of its bid. The original bid shall be stamped or otherwise marked as such.

While CRRA has no preference as to how the copies of the bid are bound, the original of the bid should be loose leaf and bound with a binder clip. In addition, tabs (numbered or lettered) should be used to delineate sections of the bid.

Each bid (the original and two copies) shall be enclosed in a sealed envelope that shall be clearly marked "Bid for Air Emissions Testing At The Mid-Connecticut Power Block Facility."

11. Period Bids Shall Remain Open

Bids shall remain open and subject to acceptance for ninety (90) days after the bid due date.

12. Non-Negotiability Of The Agreement

The terms and conditions of the Agreement (Section 15 of the RFB Package Documents), as attached, are non-negotiable. Any potential bidder that would be unable to execute the Agreement, as attached, should not submit a bid. This includes, but is not limited to, the insurance requirements (Article 6 of the Agreement).

13. Modification/Withdrawal Of A Bid

Bids may be modified or withdrawn by an appropriate document duly executed (in the manner that a bid must be executed) and delivered to CRRA's office, 100 Constitution Plaza, 6th Floor, Hartford, Connecticut 06103-1722, Attn: Ronald Gingerich, at any time prior to the bid due date.

14. Bid Security

Each bid shall be accompanied by a Bid Security. Any bid that does not contain a Bid Security or any bid that contains a Bid Security that does not comply with the following requirements shall be rejected as non-responsive.

14.1 Amount of Security

The Bid Security shall be in an amount equal to ten percent (10%) of the amount of the bid.

14.2 Type of Security

The following are the acceptable forms of Bid Security:

- (a) A cashier's check;
- (b) A certified check; or
- (c) A bid bond in the form included in Section 3 of the RFB Package Documents.

The Bid Security shall be made payable to "Connecticut Resources Recovery Authority."

Any bid bond submitted as Bid Security shall be in the form provided for such bid bond in Section 3 of the RFB and such bid bond shall be executed and issued by a surety company acceptable to CRRA. Any bid that does not contain the above requisite Bid Security or any bid that contains Bid Security that does not comply with the foregoing requirements shall be rejected as non-responsive.

14.3 Disposition of Bid Security

The Bid Security of the successful bidder will be retained until such bidder has executed the Agreement, furnished any required contract security and satisfied all other conditions of the Notice of Award, including execution and submission of the Contractor's Certification Concerning Gifts and the Affidavit Concerning Consulting Fees, whereupon such Bid Security will be returned.

If the successful bidder fails to execute and deliver the Agreement, furnish any required performance and payment security, or satisfy all other conditions of the Notice Of Award within ten (10) days after the issuance of such Notice Of Award, CRRA may annul the Notice Of Award and the Bid Security of that bidder shall be forfeited.

The Bid Security of other bidders whom CRRA believes to have a reasonable chance of receiving the award may be retained by CRRA until the earlier of the seventh (7th) day after the Effective Date of the Agreement or ninety (90) days after the bid due date, whereupon the Bid Security furnished by such bidders will be returned. Bid Security with bids that are not competitive will be returned within seven (7) days after the opening of such bids.

15. Bid Contents

Bids shall be submitted on forms provided by CRRA as part of the RFB Package Documents, all of which forms must be completed with the appropriate information required and all blanks on such forms filled in.

A bid must consist of the following and must be in the following order:

- (a) Title page of the bid (not the title page of the RFB), including the title of the project, the name of the bidder and the date the bid is submitted;
- (b) Cover letter, signed by a person authorized to commit the bidder to the contractual arrangements with CRRA, which includes the following:
 - (1) The name of the bidder;
 - (2) The legal structure of the bidder (e.g., corporation, joint venture, etc.); and
 - (3) A clear statement indicating that the attached bid constitutes a firm and binding offer by the bidder to CRRA considering the terms and conditions outlined in the RFB and noting any technical exceptions taken thereto; and
 - (4) The bidder's promise, if any, to set aside a portion of the contract for legitimate minority business enterprises (see Section 17.2(c) of this Instructions To Bidders);
- (c) Bid Security (cashier's check, certified check or bid bond) (see Section 14 of this Instructions To Bidders);
- (d) Table of Contents of the bid (not the table of contents of the RFB);
- (e) The Bid Form (Section 4 of the RFB Package Documents), with:
 - (1) Addenda, if any, listed in the appropriate place (Page 3);
 - (2) The name and address of the contact for Notices listed in the appropriate place (Page 7); and
 - (3) The completed agreement section (Page 7);
- (f) The completed Bid Price And Payment Rate Schedule Form (Section 5 of the RFB Package Documents);
- (g) The completed Business Information Form (Section 6 of the RFB Package Documents);
- (h) The completed Personnel Background And Experience Form (Section 7 of the RFB Package Documents);
- (i) The completed References Form (Section 8 of the RFB Package Documents);
- (j) The completed Subcontractor Identification Form (Section 9 of the RFB Package Documents);
- (k) The completed Questionnaire Concerning Affirmative Action, Small Business Contractors And Occupational Health And Safety form (Section 10 of the RFB Package Documents), with the bidder's most recent EEO-1 data attached if the bidder wishes such data to be considered in the evaluation of its bid;

- (l) The completed Affidavit Concerning Nondiscrimination (Section 11 of the RFB Package Documents) (subscribed and sworn before a Notary Public or Commissioner of the Superior Court);
- (m) The completed Background Questionnaire (Section 12 of the RFB Package Documents) (subscribed and sworn before a Notary Public or Commissioner of the Superior Court); and
- (n) A copy of the bidder's up-to-date certificate(s) of insurance showing all coverages required by Section 6.1 of the Agreement. [Please be advised that this is the area in which bidders seem to have the most difficulty. CRRA requires that the certificate(s) submitted show evidence of exactly the insurance requirements specified in the Agreement (e.g., if Section 6.1 of the Agreement requires Business Automobile Liability insurance covering any automobile or vehicle, the certificate of insurance must have the "any" box checked)].
- (o) As Appendix A to the bid, a brief resume (i.e., no more than two pages) of each individual listed in the Personnel Background And Experience Form.

Bidders should not include in their bids other portions of the RFB Package Documents (e.g., this Instructions To Bidders or the Agreement).

A bidder may include additional information as an addendum/appendix to its bid if the bidder thinks that it will assist CRRA in evaluating the bidder's bid. A bidder should not include information that is not directly related to the subject matter of this solicitation.

16. Bid Opening

All bids will be opened at CRRA's convenience on or after the bid due date.

17. Bid Evaluation

The award of the contract for the Services will be made, if at all, to the bidder(s) whose evaluation by CRRA results in CRRA determining that such award to such bidder(s) is in the best interests of CRRA. **However, the selection of a bidder(s) and the award of such contract, while anticipated, are not guaranteed.**

CRRA is an Equal Opportunity and Affirmative Action employer and does not discriminate in its hiring, employment, contracting, or business practices. CRRA is committed to complying with the Americans with Disability Act of 1990 (ADA) and does not discriminate on the basis of disability in admission to, access to, or operation of its programs, services, or activities.

17.1 Evaluation Criteria

CRRA will base its evaluation of the bids on the following criteria:

- (a) Price;
- (b) Qualifications;
- (c) Demonstrated skill, ability and integrity of each bidder to perform the Services required by the Contract Documents;
- (d) Adequacy of insurance coverages as evidenced by a certificate or certificates of insurance showing, at a minimum, all coverages required by Section 6.1 of the Agreement (See Section 15(n) of this Instructions To Bidders); and
- (e) Any other factor or criterion that CRRA, in its sole discretion, deems or may deem relevant or pertinent for such evaluation.

17.2 Affirmative Action Evaluation Criteria

Bids will also be rated on the bidder's demonstrated commitment to affirmative action. Sections 46a-68-1 to 46a-68-17 of the *Regulations of Connecticut State Agencies* require CRRA to consider the following factors when awarding a contract that is subject to contract compliance requirements:

- (a) The bidder's success in implementing an affirmative action plan (See Question 4 of the Questionnaire Concerning Affirmative Action, Small Business Contractors And Occupational Health And Safety (Section 10 of the RFB Package Documents));
- (b) The bidder's success in developing an apprenticeship program complying with Sections 46a-68-1 to 46a-68-17 of the *Regulations of Connecticut State Agencies*, inclusive (See Question 5 of the Questionnaire Concerning Affirmative Action, Small Business Contractors And Occupational Health And Safety (Section 10 of the RFB Package Documents));
- (c) The bidder's promise to develop and implement a successful affirmative action plan (See Question 4B of the Questionnaire Concerning Affirmative Action, Small Business Contractors And Occupational Health And Safety (Section 10 of the RFB Package Documents));
- (d) The bidder's submission of EEO-1 data indicating that the composition of its work force is at or near parity when compared to the racial and sexual composition of the work force in the relevant labor market area (See Section 15(k) of this Instructions To Bidders); and
- (e) The bidder's promise to set aside a portion of the contract for legitimate minority business enterprises (See Section 15(b)(4) of this Instructions To Bidders).

18. Contract Award

If the contract is to be awarded, CRRA will issue to the successful bidder(s) a Notice Of Award within ninety (90) days after the bid due date.

CRRA reserves the right to correct inaccurate awards resulting from CRRA's clerical errors. This may include, in extreme circumstances, revoking a Notice Of Award already made to a bidder and subsequently awarding the Notice of Award to another bidder. Such action by CRRA shall not constitute a breach of this RFB by CRRA since the Notice Of Award to the initial bidder is deemed to be void ab initio and of no effect as if no Agreement ever existed between CRRA and the initial bidder.

19. Contractor's Certification Concerning Gifts

Pursuant to *Connecticut General Statutes* Section 4-252, the apparently successful bidder(s) must submit a document certifying that it has not given any gifts to certain individuals between the date CRRA started planning the RFB and the date the Agreement is executed. If the apparently successful bidder does not execute the Certification, such bidder will be disqualified for the Agreement. The dates between which the bidder may not give gifts and the identities of those to whom it may not give gifts are specified in the attachment to the Notice Of Award included in the RFB Package Documents (see Attachment A to Section 14 of the RFB Package Documents).

20. Affidavit Concerning Consulting Fees

Pursuant to *Connecticut General Statutes* Section 4a-81, the apparently successful bidder(s) must submit an affidavit stating that, except as specified in the affidavit, it has not entered into any contract with a consultant in connection with the RFB whereby any duties of the consultant pursuant to the contract require the consultant to pursue communications concerning the business of CRRA, whether or not direct contact with CRRA was expected or made. The affidavit is attached to the Notice Of Award included in the RFB Package Documents (see Attachment B to Section 14 of the RFB Package Documents).

21. Bidder's Qualifications

CRRA may make any investigation deemed necessary to determine the ability of any bidder to perform the Services required. Each bidder shall furnish CRRA with all such information as may be required for this purpose.

22. Bid Preparation And Other Costs

Each bidder shall be solely responsible for all costs and expenses associated with the preparation and/or submission of its bid, or incurred in connection with any interviews and negotiations with CRRA, and CRRA shall have no responsibility or liability whatsoever for any such costs and expenses.

**REQUEST FOR BIDS
FOR
AIR EMISSIONS TESTING
AT THE
MID-CONNECTICUT POWER BLOCK FACILITY**

**SECTION 3
BID BOND FORM**



AIA Document A310™ – 2010

Bid Bond

CONTRACTOR:

(Name, legal status and address)

SURETY:

(Name, legal status and principal place of business)

OWNER:

(Name, legal status and address)

Connecticut Resources Recovery Authority
100 Constitution Plaza, 6th Floor
Hartford, Connecticut 06103

BOND AMOUNT: \$**PROJECT:**

(Name, location or address, and Project number, if any)

Air Emissions Testing at the Mid-Connecticut Power Block Facility
Power Block Facility
Reserve Road, Gate 20
Hartford, Connecticut 06114

ADDITIONS AND DELETIONS:

The author of this document has added information needed for its completion. The author may also have revised the text of the original AIA standard form. An *Additions and Deletions Report* that notes added information as well as revisions to the standard form text is available from the author and should be reviewed. A vertical line in the left margin of this document indicates where the author has added necessary information and where the author has added to or deleted from the original AIA text.

This document has important legal consequences. Consultation with an attorney is encouraged with respect to its completion or modification.

Any singular reference to Contractor, Surety, Owner or other party shall be considered plural where applicable.

The Contractor and Surety are bound to the Owner in the amount set forth above, for the payment of which the Contractor and Surety bind themselves, their heirs, executors, administrators, successors and assigns, jointly and severally, as provided herein. The conditions of this Bond are such that if the Owner accepts the bid of the Contractor within the time specified in the bid documents, or within such time period as may be agreed to by the Owner and Contractor, and the Contractor either (1) enters into a contract with the Owner in accordance with the terms of such bid, and gives such bond or bonds as may be specified in the bidding or Contract Documents, with a surety admitted in the jurisdiction of the Project and otherwise acceptable to the Owner, for the faithful performance of such Contract and for the prompt payment of labor and material furnished in the prosecution thereof; or (2) pays to the Owner the difference, not to exceed the amount of this Bond, between the amount specified in said bid and such larger amount for which the Owner may in good faith contract with another party to perform the work covered by said bid, then this obligation shall be null and void, otherwise to remain in full force and effect. The Surety hereby waives any notice of an agreement between the Owner and Contractor to extend the time in which the Owner may accept the bid. Waiver of notice by the Surety shall not apply to any extension exceeding sixty (60) days in the aggregate beyond the time for acceptance of bids specified in the bid documents, and the Owner and Contractor shall obtain the Surety's consent for an extension beyond sixty (60) days.

If this Bond is issued in connection with a subcontractor's bid to a Contractor, the term Contractor in this Bond shall be deemed to be Subcontractor and the term Owner shall be deemed to be Contractor.

When this Bond has been furnished to comply with a statutory or other legal requirement in the location of the Project, any provision in this Bond conflicting with said statutory or legal requirement shall be deemed deleted herefrom and provisions conforming to such statutory or other legal requirement shall be deemed incorporated herein. When so

Init.

AIA Document A310™ – 2010. Copyright © 1963, 1970 and 2010 by The American Institute of Architects. All rights reserved. WARNING: This AIA® Document is protected by U.S. Copyright Law and International Treaties. Unauthorized reproduction or distribution of this AIA® Document, or any portion of it, may result in severe civil and criminal penalties, and will be prosecuted to the maximum extent possible under the law. This document was produced by AIA software at 11:38:02 on 03/17/2011 under Order No.8003794840_1 which expires on 07/21/2011, and is not for resale.

User Notes:

(1379231347)

Additions and Deletions Report for **AIA[®] Document A310[™] – 2010**

This Additions and Deletions Report, as defined on page 1 of the associated document, reproduces below all text the author has added to the standard form AIA document in order to complete it, as well as any text the author may have added to or deleted from the original AIA text. Added text is shown underlined. Deleted text is indicated with a horizontal line through the original AIA text.

Note: This Additions and Deletions Report is provided for information purposes only and is not incorporated into or constitute any part of the associated AIA document. This Additions and Deletions Report and its associated document were generated simultaneously by AIA software at 11:38:02 on 03/17/2011.

PAGE 1

Connecticut Resources Recovery Authority
100 Constitution Plaza, 6th Floor
Hartford, Connecticut 06103

...

(Name, location or address, and Project number, if any)
Air Emissions Testing at the Mid-Connecticut Power Block Facility
Power Block Facility
Reserve Road, Gate 20
Hartford, Connecticut 06114

Certification of Document's Authenticity

AIA® Document D401™ – 2003

I, Ronald E. Gingerich, hereby certify, to the best of my knowledge, information and belief, that I created the attached final document simultaneously with its associated Additions and Deletions Report and this certification at 11:38:02 on 03/17/2011 under Order No. 8003794840_1 from AIA Contract Documents software and that in preparing the attached final document I made no changes to the original text of AIA® Document A310™ – 2010, Bid Bond, as published by the AIA in its software, other than those additions and deletions shown in the associated Additions and Deletions Report.



(Signed)

DEVELOPMENT MANAGER

(Title)

4/28/11

(Dated)

**REQUEST FOR BIDS
FOR
AIR EMISSIONS TESTING
AT THE
MID-CONNECTICUT POWER BLOCK FACILITY**

**SECTION 4
BID FORM**



BID FORM

PROJECT: Mid-Connecticut

RFB NUMBER: 12-EN-001

CONTRACT FOR: Air Emissions Testing at the Mid-Connecticut Power Block Facility

BID SUBMITTED TO: Connecticut Resources Recovery Authority
100 Constitution Plaza, 6th Floor
Hartford, Connecticut 06103-1722

1. DEFINITIONS

Unless otherwise defined herein, all terms that are not defined and used in this Bid Form (a “Bid”) shall have the same respective meanings assigned to such terms in the Contract Documents.

2. TERMS AND CONDITIONS

The undersigned (the “Bidder”) accepts and agrees to all terms and conditions of the Request For Bids, Instructions To Bidders, the Agreement and any Addenda to any such documents. This Bid shall remain open and subject to acceptance for ninety (90) days after the bid due date.

If CRRA issues a Notice Of Award to Bidder, Bidder shall within ten (10) days after the date thereof:

- (a) Execute and deliver to CRRA the required number of counterparts of the non-negotiable Agreement;
- (b) Execute and deliver to CRRA the Contractor’s Certification Concerning Gifts;
- (c) Execute and deliver to CRRA the Affidavit Concerning Consulting Fees;
- (d) Deliver to CRRA the requisite certificate(s) of insurance;

- (e) Execute and deliver to CRRA all other Contract Documents attached to the Notice Of Award along with any other documents required by the Contract Documents; and
- (f) Satisfy all other conditions of the Notice Of Award.

3. BIDDER'S OBLIGATIONS

Bidder proposes and agrees, if this Bid is accepted by CRRA and CRRA issues a Notice Of Award to Bidder, to the following:

- (a) To perform, furnish and complete all the Services as specified or indicated in the Contract Documents and Agreement for the not-to-exceed-bid price, in conformance with the payment rate schedule, within the Contract Time set forth in this Bid and in accordance with the terms and conditions of the Contract Documents and Agreement; and
- (b) At the request of CRRA and if the successful Bidder qualifies, to apply with the State of Connecticut Department Administrative Services, and do all that is necessary to make itself qualify, as a Small Contractor and/or Minority/Women/Disabled Person Business Enterprise in accordance with Section 4a-60g of the *Connecticut General Statutes*.

4. BIDDER'S REPRESENTATIONS CONCERNING NON-NEGOTIABILITY OF THE AGREEMENT

In submitting this Bid, Bidder acknowledges and agrees that the terms and conditions of the Agreement (including all Exhibits thereto), as included in the RFB Package Documents, are non-negotiable, and Bidder is willing to and shall, if CRRA accepts its Bid for the Services and issues a Notice Of Award to Bidder, execute such Agreement. However, CRRA reserves the right to negotiate with Bidder over Bidder's price for the Services submitted on its Bid Price And Payment Rate Schedule Form.

5. BIDDER'S REPRESENTATIONS CONCERNING EXAMINATION OF CONTRACT DOCUMENTS

In submitting this Bid, Bidder represents that:

- (a) Bidder has thoroughly examined and carefully studied the RFB Package Documents and the following Addenda, receipt of which is hereby acknowledged (list Addenda by Addendum number and date):

Addendum Number	Date Issued

- (b) Without exception the Bid is premised upon performing, furnishing and completing the Services required by the Contract Documents and applying the specific means, methods, techniques, sequences or procedures (if any) that may be shown, indicated or expressly required by the Contract Documents;
- (c) Bidder is fully informed and is satisfied as to all Laws And Regulations that may affect cost, progress, performance, furnishing and/or completion of the Services;
- (d) Bidder has studied and carefully correlated Bidder's knowledge and observations with the Contract Documents and such other related data;
- (e) Bidder has given CRRA written notice of all conflicts, errors, ambiguities and discrepancies that Bidder has discovered in the Contract Documents and the written resolutions thereof by CRRA are acceptable to Bidder;
- (f) If Bidder has failed to promptly notify CRRA of all conflicts, errors, ambiguities and discrepancies that Bidder has discovered in the Contract Documents, such failure shall be deemed by both Bidder and CRRA to be a waiver to assert these issues and claims in the future;
- (g) Bidder is aware of the general nature of work to be performed by CRRA and others that relates to the Services for which this Bid is submitted; and
- (h) The Contract Documents are generally sufficient to indicate and convey understanding by Bidder of all terms and conditions for performing, furnishing and completing the Services for which this Bid is submitted.

6. BIDDER'S REPRESENTATIONS CONCERNING SITE CONDITIONS

In submitting this Bid, Bidder acknowledges and agrees that:

- (a) All information and data included in the RFB Package Documents relating to the surface, subsurface and other conditions of the Site are from presently available sources and are being provided only for the information and convenience of the bidders;
- (b) CRRA does not assume any responsibility for the accuracy or completeness of such information and data, if any, shown or indicated in the Contract Documents with respect to any surface, subsurface or other conditions of the Site;

- (c) Bidder is solely responsible for investigating and satisfying itself as to all actual and existing Site conditions, including surface conditions, subsurface conditions and underground facilities; and
- (d) Bidder has visited the Site and has become familiar with and is satisfied as to the general, local, and site conditions that may affect cost, progress, performance, furnishing and completion of the Services.

7. BIDDER'S REPRESENTATIONS CONCERNING INFORMATION MADE AVAILABLE

In submitting this Bid, Bidder acknowledges and agrees that Bidder shall not use any information made available to it or obtained in any examination made by it in connection with this RFB in any manner as a basis or grounds for a claim or demand of any nature against CRRA arising from or by reason of any variance which may exist between information offered or so obtained and the actual materials, conditions, or structures encountered during performance of any of the Services.

8. BIDDER'S REPRESENTATIONS CONCERNING STATE OF CONNECTICUT TAXES

In submitting this Bid, Bidder acknowledges and agrees that CRRA is exempt from all State of Connecticut taxes and assessments, including sales and use taxes. Accordingly, Bidder shall not charge CRRA any State of Connecticut taxes or assessments at any time in connection with Bidder's performance of this Agreement, nor shall Bidder include any State of Connecticut taxes or assessments in any rates, costs, prices or other charges to CRRA hereunder. Bidder represents and warrants that no State of Connecticut taxes or assessments were included in any rates, costs, prices or other charges presented to CRRA in any bid or other submittal to CRRA in connection with this RFB.

9. BIDDER'S REPRESENTATIONS CONCERNING DISCLOSURE OF INFORMATION

In submitting this Bid, Bidder:

- (a) Recognizes and agrees that CRRA is subject to the Freedom of Information provisions of the *Connecticut General Statutes* and, as such, any information contained in or submitted with or in connection with Bidder's Bid is subject to disclosure if required by law or otherwise; and
- (b) Expressly waives any claim(s) that Bidder or any of its successors and/or assigns has or may have against CRRA or any of its directors, officers, employees or authorized agents as a result of any such disclosure.

10. BIDDER'S REPRESENTATIONS CONCERNING NON-COLLUSION

By submission of this Bid, the Bidder, together with any affiliates or related persons, the guarantor, if any, and any joint ventures, hereby represents that, under risk of termination of the Agreement, if awarded, to the best of its knowledge and belief:

- (a) The prices in the Bid have been arrived at as the result of an independent business judgment without collusion, consultation, communication, agreement or otherwise for the purpose of restricting competition, as to any matter relating to such prices and any other person or company;
- (b) Unless otherwise required by law, the prices that have been quoted in this Bid have not, directly or indirectly, been knowingly disclosed by the Bidder prior to "opening" to any other person or company;
- (c) No attempt has been made or will be made by the Bidder to induce any other person, partnership or corporation to submit, or not to submit, a bid for the purpose of restricting competition;
- (d) Bidder has not directly or indirectly induced or solicited any other bidder to submit a false or sham bid; and
- (e) Bidder has not sought by collusion to obtain for itself any advantage for the Services over any other bidder for the Services or over CRRA.

11. BIDDER'S REPRESENTATIONS CONCERNING RFB FORMS

By submission of this Bid, the Bidder, together with any affiliates or related business entities or persons, the guarantor, if any, and any joint ventures, hereby represents that, under risk of termination of the Agreement, if awarded, all of the forms included in the RFB that are submitted to CRRA as part of its Bid are identical in form and content to the preprinted forms in the RFB Package Documents except that information requested by the forms has been inserted in the spaces on the forms provided for the insertion of such requested information.

12. BID SECURITY

Bidder acknowledges and agrees that the amount of the Bid Security submitted with this Bid fairly and reasonably represents the amount of damages CRRA will suffer in the event that Bidder fails to fulfill any of its obligations set forth in the Contract Documents.

13. BIDDER'S WAIVER OF DAMAGES

Bidder and all its affiliates and subsidiaries understand that by submitting a Bid, Bidder is acting at its and their own risk and Bidder does for itself and all its affiliates, subsidiaries, successors and assigns hereby waive any rights any of them may have to receive any damages for any liability, claim, loss or injury resulting from:

- (a) Any action or inaction on the part of CRRA or any of its directors, officers, employees or authorized agents concerning the evaluation, selection, non-selection and/or rejection of any or all bids by CRRA or any of its directors, officers, employees or authorized agents;
- (b) Any agreement entered into for the Services (or any part thereof) described in the Contract Documents with any other bidder; and/or
- (c) Any award or non-award of a contract for the Services (or any part thereof) pursuant to the Contract Documents.

14. BIDDER'S REPRESENTATION REGARDING THE CONNECTICUT CAMPAIGN CONTRIBUTION AND SOLICITATION BAN

With regard to a State contract as defined in P.A. 07-1 having a value in a calendar year of \$50,000 or more or a combination or series of such agreement or contracts having a value of \$100,000 or more, the authorized signatory to this submission in response to CRRA's solicitation expressly acknowledges receipt of the State Elections Enforcement Commission's notice advising prospective state contractors of state campaign contribution and solicitation prohibitions, and will inform its principals of the contents of the notice. See Section 13 [SEEC Form 11] of the RFB Package Documents.

15. ATTACHMENTS

The following documents are attached hereto and made a part of this Bid:

- (a) The properly executed Bid Security;
- (b) The completed Bid Price And Payment Rate Schedule Form;
- (c) The completed Business Information Form;
- (d) The completed Personnel Background And Experience Form;
- (e) The completed References Form;
- (f) The completed Subcontractor Identification Form;
- (g) The Questionnaire Concerning Affirmative Action, Small Business Contractors And Occupational Health And Safety that has been completely filled out by the Bidder;
- (h) The Affidavit Concerning Nondiscrimination that has been completely filled out by the Bidder and signed before a Notary Public or Commissioner of the Superior Court;
- (i) The Background Questionnaire that has been completely filled out by the Bidder and signed before a Notary Public or Commissioner of the Superior Court;

- (j) A copy of the Bidder's up-to-date certificate of insurance showing all insurance coverages required by Section 6.1 of the Agreement; and
- (k) Brief resumes of each individual listed in the Personnel Background And Experience Form.

16. NOTICES

Communications concerning this Bid should be addressed to Bidder at the address set forth below.

Bidder Name:	
Bidder Contact:	
Title:	
Street Address:	
Street Address:	
City, State, Zip Code	
Telephone Number:	
Fax Number:	
E-Mail Address:	

17. ADDITIONAL REPRESENTATION

Bidder hereby represents that the undersigned is duly authorized to submit this Bid on behalf of Bidder.

AGREED TO AND SUBMITTED ON _____, 20 11

Name of Bidder (Firm):	
Signature of Bidder Representative:	
Name (Typed/Printed):	
Title (Typed/Printed):	

**REQUEST FOR BIDS
FOR
AIR EMISSIONS TESTING
AT THE
MID-CONNECTICUT POWER BLOCK FACILITY**

**SECTION 5
BID PRICE
AND
PAYMENT RATE SCHEDULE FORM**



BID PRICE AND PAYMENT RATE SCHEDULE FORM

AIR EMISSIONS TESTING AT THE MID-CONNECTICUT POWER BLOCK FACILITY (RFB Number 12-EN-001)

1. NOT-TO-EXCEED BID PRICE

Fill in the "Not-To-Exceed Bid Price" for Each Task for Each Year and the Totals in the table on the following page. Also fill in the "Total Not-To-Exceed Bid Price."

In preparing a Not-To-Exceed Bid Price, bidders should carefully study the Scope Of Services. Bidders should make special note of the following:

- (a) The Contractor will be provided with electrical hookup, Continuous Emission Monitoring (CEM) data, and access to the Site and a Facility liaison person. The Contractor must provide any other needed tools, devices, equipment, supplementary access, information, transportation, communication, labor, and supervision to perform the field services.
- (b) Laboratory analysis will be required to be performed on an expedited basis so as to allow the greatest opportunity for CRRA review of the draft test report prior to submission to CTDEP.
- (c) The inlet duct sampling locations have very restricted access, very limited working space and are at an elevated level above the ground. The Contractor is responsible for the cost for all special accommodations that must be made for safely obtaining samples from these locations. Such accommodations may include, but are not limited to, rigging, tools and additional labor.
- (d) The CTDEP may require the Contractor to analyze five "audit samples" as a quality control/quality assurance measure. These are one dioxin/furan, two hydrogen chloride, one metals (cadmium and lead) and one metals (mercury). Contractor's Not-To-Exceed Bid Price for Laboratory Analysis shall cover analysis of these samples.
- (e) Note that the prices shall be for (1) Field Services, (2) Laboratory Analysis and (3) Regulatory Document Preparation and Submittal in 2012, 2013 and 2014. For the purposes of bidding, it shall be assumed that one unit shall be tested for dioxin/furans in 2012 and that all three units shall be tested for dioxin/furans in 2013 and 2014.

TASK	NOT-TO-EXCEED BID PRICE			
	2012	2013	2014	TOTAL
1. Field Services	\$	\$	\$	\$
2. Laboratory Analysis	\$	\$	\$	\$
3. Regulatory Document Preparation and Submittal	\$	\$	\$	\$
TOTAL	\$	\$	\$	\$

TOTAL NOT-TO-EXCEED BID PRICE (Total of Tasks 1 through 3 for Years 2012, 2013 and 2014):

Total Not-To-Exceed Bid Price	
Dollars	Cents
(Use Numbers)	

(Use Words)

2. PAYMENT RATE SCHEDULE

In addition to the form on the preceding page, each Bidder must submit on the forms on this and the following pages a listing of hourly billing rates (both regular time and overtime) for each staff level of personnel in its firm who will be assigned to work with CRRA. Bidder must also provide the rate at which applicable ancillary services are billed, including, but not limited to:

- Word processing;
- Copying (per page);
- Computer time;
- Laboratory analysis (include bottle preparation, delivery and pickup, equipment, field and trip blanks, QA/QC and other services); and
- Any other services (excluding telephones) for which Bidder routinely bills.

BILLING RATES
(Provide Billing Rates Below)
 (Use Additional Sheets If Necessary)

Labor Category	Title	Hourly Rate		
		2012	2013	2014
1	Senior Principal Consultant			
2	Principal Consultant/Program Director			
3	Senior Project Manager			
4	Project Manager			
5	Associate Project Manager			
6	Field Supervisor II/Engineer III/Scientist III			
7	Field Supervisor I/Engineer II/Scientist II			
8	Technical Specialist/Engineer I/Scientist I			
9	Clerical Technical Assistant			

OVERTIME RATES

For employees who are eligible for and are paid a higher hourly rate for overtime than the hourly rate listed on the preceding page, the successful Bidder will be entitled to reimbursement for such employee overtime when such overtime is a result of more than 8 hours in one day and/or more than 40 hours in one week worked on this Project by such an employee.

Below, specify the proposed rate for overtime (i.e., the percentage by which the hourly rates specified on the preceding page would be multiplied to arrive at the overtime rate).

	% (fill in the percentage rate for overtime)
--	---

ANCILLARY SERVICE RATES (Provide Rates Below)

(Use Additional Sheets If Necessary)

Ancillary Service	Rate		
	2012	2013	2014
Word Processing (Per Hour)			
Copying (Per Page)			
Travel in Firm-Owned Vehicle (Per Mile)			
Computer Time (Per Hour)			
Any Other Services For Which You Routinely Bill (List Below)			

**REQUEST FOR BIDS
FOR
AIR EMISSIONS TESTING
AT THE
MID-CONNECTICUT POWER BLOCK FACILITY**

**SECTION 6
BUSINESS INFORMATION FORM**



BUSINESS INFORMATION FORM

Bidder/Proposer/Statement of Qualifications Submitter (hereinafter collectively referred to as "Contractor") must provide the information requested in the following sections/tables.

1. CONTRACTOR INFORMATION

Name of Entity:			
Central Office/ Headquarters Address:	Address 1:		
	Address 2:		
	City, State, Zip Code:		
Servicing Office Address (if different than Central Office/ Headquarters Address):	Address 1:		
	Address 2:		
	City, State, Zip Code:		
Name of Parent Company (if any):			
Entity's Legal Structure:		<input type="checkbox"/> Corporation <input type="checkbox"/> Partnership <input type="checkbox"/> Other	<input type="checkbox"/> Joint Venture <input type="checkbox"/> Public Entity
State in Which Entity is Legally Organized:			
Year Entity Started:		Number of Professional Employees:	Number of Offices:
Location(s) of Offices (City and State)	# of Employ- ees	Location(s) of Offices (City and State)	# of Employ- ees
1.		5.	
2.		6.	
3.		7.	
4.		8.	

Brief History of the Entity:	
Overview of Entity's Principal Lines of Work:	

2. BACKGROUND AND EXPERIENCE

- (a) In the space below, describe the entity's knowledge, capability and experience providing services similar to the services addressed in this RFB. Specifically describe work regarding air emissions testing and, more specifically, any work regarding air emissions testing at municipal solid waste combustors.

- (b) In the space below, provide a proposed schedule for the air emissions testing. The schedule may not include sampling at more than two sites simultaneously (i.e., bids should reflect that sampling will only be done at the inlet and outlet of one unit or at the outlets of two units simultaneously).

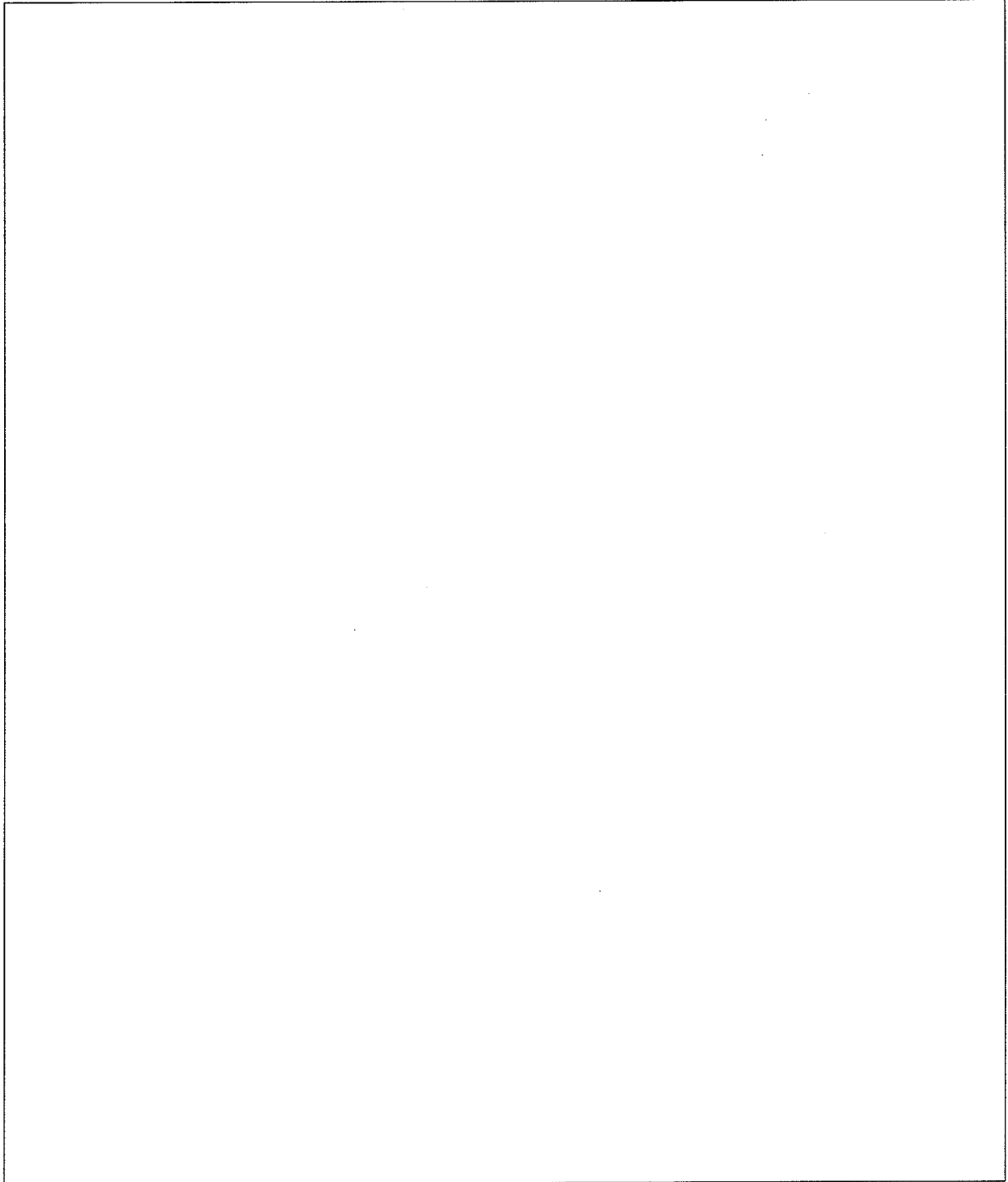

- (c) In the space below, describe your firm's training and oversight regarding field work associated with air emissions testing.

A large, empty rectangular box with a thin black border, intended for the user to provide a detailed description of their firm's training and oversight regarding field work associated with air emissions testing.

- (d) In the space below, describe your firm's quality assurance/quality control program associated with air emissions testing.

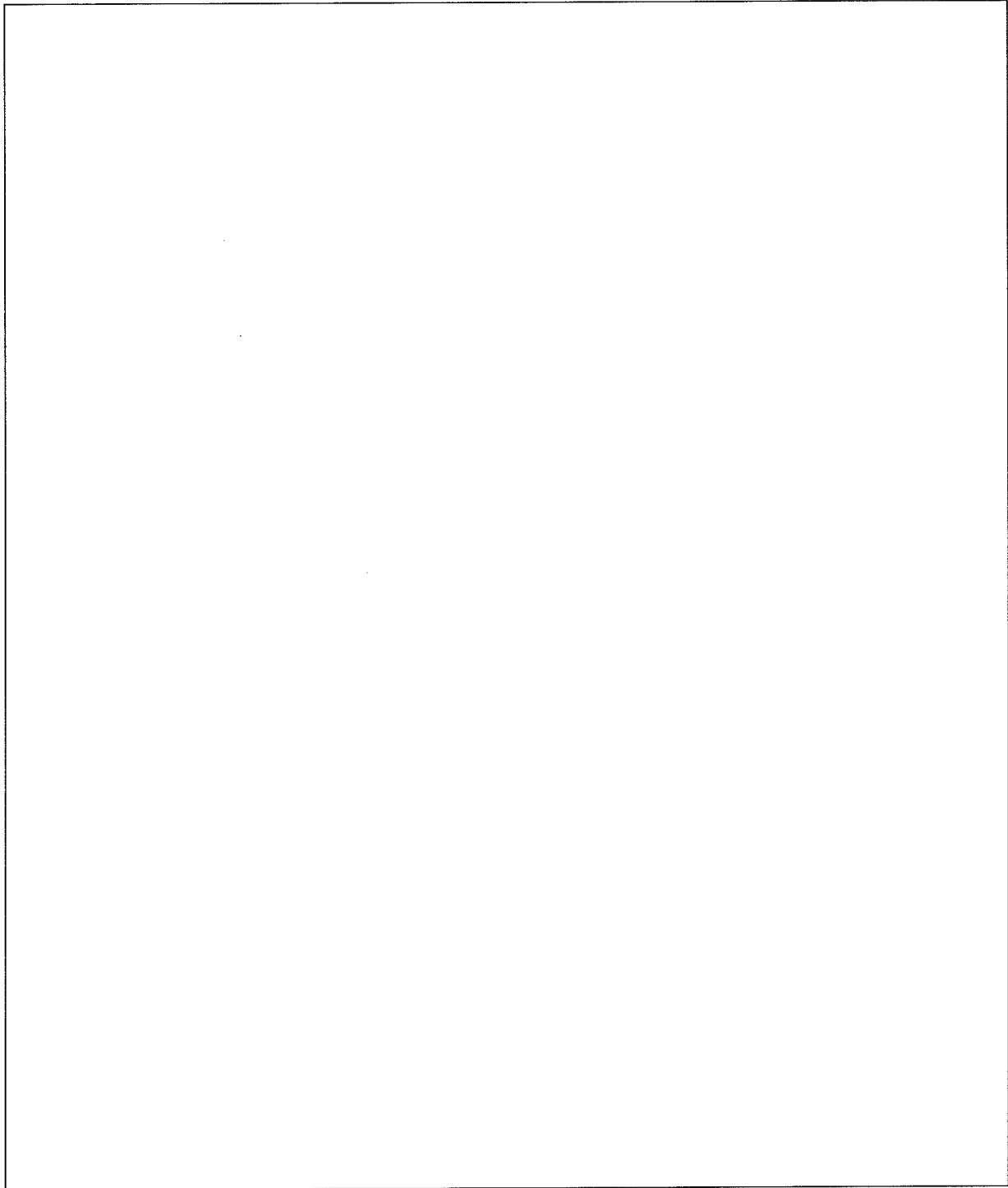
A large, empty rectangular box with a thin black border, intended for the user to describe their firm's quality assurance/quality control program associated with air emissions testing.

**REQUEST FOR BIDS
FOR
AIR EMISSIONS TESTING
AT THE
MID-CONNECTICUT POWER BLOCK FACILITY**

**SECTION 7
PERSONNEL BACKGROUND AND
EXPERIENCE FORM**



PERSONNEL BACKGROUND AND EXPERIENCE FORM

In the tables on the following pages, provide the requested information on the professionals (i.e., principal engineers and scientists) who would be assigned to work with CRRA. In completing the forms below, please note the following:

- The first professional listed should be the person who would be the key contact for field services associated with air emissions testing.
- In the "Staff Level" item, indicate the individual's staff level as specified on the Bid Price And Payment Rate Schedule Form (Section 5 of the RFB Package Documents).
- In the "% of Time Available" item, indicate the percentage of the individual's time that he/she would be available to provide services to CRRA.

If more than 10 individuals would be assigned to work with CRRA, copy page 6 of this form and use it to provide the requested information for the additional individuals.

Provide a brief resume (i.e., no more than two pages) of each individual listed on this Form as Appendix A to the bid.

PROFESSIONAL 1 – Key Contact for Field Services

Name:		Staff Level:	
Title:		% of Time Available:	
Probable Areas of Responsibility:			
Background:			

PROFESSIONAL 2

Name:		Staff Level:	
Title:		% of Time Available:	
Probable Areas of Responsibility:			
Background:			

PROFESSIONAL 3

Name:		Staff Level:	
Title:		% of Time Available:	
Probable Areas of Responsibility:			
Background:			

PROFESSIONAL 4

Name:		Staff Level:	
Title:		% of Time Available:	
Probable Areas of Responsibility:			
Background:			

PROFESSIONAL 5

Name:		Staff Level:	
Title:		% of Time Available:	
Probable Areas of Responsibility:			
Background:			

PROFESSIONAL 6

Name:		Staff Level:	
Title:		% of Time Available:	
Probable Areas of Responsibility:			
Background:			

PROFESSIONAL 7

Name:		Staff Level:	
Title:		% of Time Available:	
Probable Areas of Responsibility:			
Background:			

PROFESSIONAL 8

Name:		Staff Level:	
Title:		% of Time Available:	
Probable Areas of Responsibility:			
Background:			

PROFESSIONAL 9

Name:		Staff Level:	
Title:		% of Time Available:	
Probable Areas of Responsibility:			
Background:			

PROFESSIONAL 10

Name:		Staff Level:	
Title:		% of Time Available:	
Probable Areas of Responsibility:			
Background:			

**REQUEST FOR BIDS
FOR
AIR EMISSIONS TESTING
AT THE
MID-CONNECTICUT POWER BLOCK FACILITY**

**SECTION 8
REFERENCES FORM**



REFERENCES FORM

In space below, provide the names of three (3) non-CRRA references who can attest to the quality of work performed/services provided by Bidder/Proposer/Statement of Qualifications Submitter. Include job title, the name, address and phone number of the business and a brief description of the work performed/services provided for each reference.

REFERENCE 1

Name of Person:	
Title:	
Name of Business:	
Address:	
Telephone Number:	
Brief Description Of Work Performed/ Services Provided:	

REFERENCE 2

Name of Person:	
Title:	
Name of Business:	
Address:	
Telephone Number:	
Brief Description Of Work Performed/ Services Provided:	

REFERENCE 3

Name of Person:	
Title:	
Name of Business:	
Address:	
Telephone Number:	
Brief Description Of Work Performed/ Services Provided:	

**REQUEST FOR BIDS
FOR
AIR EMISSIONS TESTING
AT THE
MID-CONNECTICUT POWER BLOCK FACILITY**

**SECTION 9
SUBCONTRACTOR IDENTIFICATION FORM**



SUBCONTRACTOR IDENTIFICATION FORM
--

Bidder/Proposer/Statement of Qualifications Submitter (hereinafter collectively referred to as "Contractor") shall list below all subcontractor(s) Contractor intends to use in the performance of Work/Services if Contractor is selected to perform the Work/Services and awarded the Agreement. Contractor shall include a description of the Work/Services to be provided by each of the subcontractor(s).

Subcontractor 1

Company Name	
Work/Services To Be Provided	

Subcontractor 2

Company Name	
Work/Services To Be Provided	

Subcontractor 3

Company Name	
Work/Services To Be Provided	

Subcontractor 4

Company Name	
Work/Services To Be Provided	

**REQUEST FOR BIDS
FOR
AIR EMISSIONS TESTING
AT THE
MID-CONNECTICUT POWER BLOCK FACILITY**

SECTION 10

**QUESTIONNAIRE CONCERNING
AFFIRMATIVE ACTION, SMALL BUSINESS
CONTRACTORS AND OCCUPATIONAL
HEALTH AND SAFETY**



QUESTIONNAIRE CONCERNING AFFIRMATIVE ACTION, SMALL BUSINESS CONTRACTORS AND OCCUPATIONAL HEALTH AND SAFETY

Because CRRA is a political subdivision of the State of Connecticut, it is required by various statutes and regulations to obtain background information on prospective contractors prior to entering into a contract. The questions below are designed to assist CRRA in procuring this information. Many of the questions are required to be asked by RCSA 46a-68j-31. For the purposes of this form, "Contractor" means Bidder, Proposer or Statement of Qualifications Submitter, as appropriate.

	Yes	No
1. Is the Contractor an Individual? <i>If you answered "Yes" to Question 1, skip to Question 2.</i> <i>If you answered "No" to Question 1, proceed to Question 1A and then to Question 2.</i>	<input type="checkbox"/>	<input type="checkbox"/>
1A. How many employees does the Contractor have? <input type="text"/>		
2. Is the Contractor a Small Business Enterprise based on the criteria in Schedule A? <i>If you answered "Yes" to Question 2, proceed to Question 2A and then to Question 3.</i> <i>If you answered "No" to Question 2, skip to Question 3.</i>	<input type="checkbox"/>	<input type="checkbox"/>
2A. Is the Contractor certified by DAS as a Small Business Enterprise? ¹	<input type="checkbox"/>	<input type="checkbox"/>
3. Is the Contractor a Minority Owned Business Enterprise based on the criteria in Schedule B? <i>If you answered "Yes" to Question 3, proceed to Question 3A and then to Question 4.</i> <i>If you answered "No" to Question 3, skip to Question 4.</i>	<input type="checkbox"/>	<input type="checkbox"/>
3A. Is the Contractor certified by DAS as a Minority Owned Business Enterprise? ¹	<input type="checkbox"/>	<input type="checkbox"/>
4. Does the Contractor have an Affirmative Action Plan? ² <i>If you answered "Yes" to Question 4, proceed to Question 4A and then to Question 5.</i> <i>If you answered "No" to Question 4, skip to Question 4B and then to Question 5.</i>	<input type="checkbox"/>	<input type="checkbox"/>
4A. Has the Affirmative Action Plan been approved by the CHRO?	<input type="checkbox"/>	<input type="checkbox"/>
4B. Will the Contractor develop and implement an Affirmative Action Plan?	<input type="checkbox"/>	<input type="checkbox"/>
5. Does the Contractor have an apprenticeship program complying with RCSA 46a-68-1 through 46a-68-17?	<input type="checkbox"/>	<input type="checkbox"/>
6. Has the Contractor been cited for three or more willful or serious violations of any occupational safety and health act?	<input type="checkbox"/>	<input type="checkbox"/>
7. Has the Contractor received one or more criminal convictions related to the injury or death of any employee in the three-year period preceding the issuance of this Request For Bids/Proposals/Qualifications?	<input type="checkbox"/>	<input type="checkbox"/>
8. Has the Contractor been the recipient of one or more ethical violations from the State of Connecticut Ethics Commission during the three-year period preceding the issuance of this Request For Bids/Proposals/Qualifications?	<input type="checkbox"/>	<input type="checkbox"/>
9. Will subcontractors be involved? <i>If you answered "Yes" to Question 9, proceed to Question 9A.</i> <i>If you answered "No" to Question 9, you are finished with the questionnaire.</i>	<input type="checkbox"/>	<input type="checkbox"/>
9A. How many subcontractors will be involved? <input type="text"/>		

LIST OF ACRONYMS

- RCSA – Regulations of Connecticut State Agencies
CHRO – State of Connecticut Commission on Human Rights and Opportunities
DAS – State of Connecticut Department of Administrative Services

FOOTNOTES

- ¹ If the Contractor answered "yes" to Question 2A and/or 3A, Contractor must attach a copy of its DAS Set-Aside Certificate to this Questionnaire.
- ² If the Contract is a "public works contract" (as defined in Section 46a-68b of the Connecticut General Statutes), the dollar amount exceeds Fifty Thousand Dollars (\$50,000.00) in any fiscal year, and the Contractor has fifty (50) or more employees, the Contractor, in accordance with the provisions of Section 46a-68c of the Connecticut General Statutes, shall develop and file an affirmative action plan with the Connecticut Commission on Human Rights and Opportunities.

SCHEDULE A CRITERIA FOR A SMALL BUSINESS ENTERPRISE

Contractor must meet all of the following criteria to qualify as a Small Business Enterprise:

1. Has been doing business under the same ownership or management and has maintained its principal place of business in the Connecticut for at least one year immediately prior to the issuance of the Request For Bids/ Proposals/Qualifications;
2. Has had gross revenues not exceeding fifteen million dollars (\$15,000,000) during its most recent fiscal year; and
3. At least 51% of the ownership of the Contractor is held by a person(s) who exercises the operational authority over daily affairs of the business and has the power to direct policies and management and receives beneficial interests of the business.

SCHEDULE B CRITERIA FOR A MINORITY OWNED BUSINESS ENTERPRISE

Contractor must meet all of the following criteria to qualify as a Minority Owned Business Enterprise:

1. Satisfies all of the criteria in Schedule A for a Small Business Enterprise;
2. At least 51% of the ownership of the Contractor by one or more minority person(s) who exercises operational authority over daily affairs of the business, has the power to direct management and policies and receives the beneficial interests of the business;
3. A minority is a person(s) who is American Indian, Asian, Black, Hispanic, has origins in the Iberian Peninsula, a woman, or an individual with a disability.

CONNECTICUT GENERAL STATUTES SECTION 46a-68b

As used in this section and sections 4a-60, 4a-60a, 4a-60g, 4a-62, 46a-56 and 46a-68c to 46a-68k, inclusive: "Public works contract" means any agreement between any individual, firm or corporation and the state or any political subdivision of the state other than a municipality for construction, rehabilitation, conversion, extension, demolition or repair of a public building, highway or other changes or improvements in real property, or which is financed in whole or in part by the state, including, but not limited to, matching expenditures, grants, loans, insurance or guarantees.

**REQUEST FOR BIDS
FOR
AIR EMISSIONS TESTING
AT THE
MID-CONNECTICUT POWER BLOCK FACILITY**

**SECTION 11
AFFIDAVIT CONCERNING
NONDISCRIMINATION**



**AFFIDAVIT CONCERNING
NONDISCRIMINATION**

This Affidavit must be completed and properly executed under penalty of false statement by a chief executive officer, president, chairperson, member or other corporate officer duly authorized to adopt company, corporate or partnership policy of the business entity submitting a bid/proposal/statement of qualifications to the Connecticut Resources Recovery Authority that certifies such business entity complies with the nondiscrimination agreement and warranties contained in Connecticut General Statutes §§ 4a-60(a)(1) and 4a-60a(a)(1), as amended, regarding nondiscrimination against persons on account of their race, color, religious creed, age, marital status, national origin, ancestry, sex, mental retardation, mental disability, physical disability or sexual orientation.

I, the undersigned, am over the age of eighteen and understand and appreciate the obligation of an oath.
I am _____ (title) of _____ (firm name), an entity duly formed and existing under the laws of _____ (name of state or commonwealth) ("Contractor").

I certify that I am authorized to execute and deliver this affidavit on behalf of Contractor, as follows:

1. Contractor seeks to enter into the "Agreement for Air Emissions Testing at the Mid-Connecticut Power Block Facility" (the "Agreement") with the Connecticut Resources Recovery Authority; and
2. Contractor has in place a company or corporate policy that complies with the nondiscrimination agreements and warranties required under Connecticut General Statutes §§ 4a-60(a)(1) and 4a-60a(a)(1), as amended, and the said company or corporate policy is in effect as of the date hereof.

By (Signature): _____
Name (Print): _____
Title: _____

Sworn to before me this _____ day of _____ 20 _____

Notary Public/Commissioner of the Superior Court

Commission Expiration Date

Sections 4a-60(a)(1) and 4a-60a(a)(1) of the Connecticut General Statutes follow.

Sec. 4a-60. (Formerly Sec. 4-114a). Nondiscrimination and affirmative action provisions in contracts of the state and political subdivisions other than municipalities.

- (a) Every contract to which the state or any political subdivision of the state other than a municipality is a party shall contain the following provisions:
 - (1) The contractor agrees and warrants that in the performance of the contract such contractor will not discriminate or permit discrimination against any person or group of persons on the grounds of race, color, religious creed, age, marital status, national origin, ancestry, sex, mental retardation, mental disability or physical disability, including, but not limited to, blindness, unless it is shown by such contractor that such disability prevents performance of the work involved, in any manner prohibited by the laws of the United States or of the state of Connecticut; and the contractor further agrees to take affirmative action to insure that applicants with job-related qualifications are employed and that employees are treated when employed without regard to their race, color, religious creed, age, marital status, national origin, ancestry, sex, mental retardation, mental disability or physical disability, including, but not limited to, blindness, unless it is shown by such contractor that such disability prevents performance of the work involved;

Sec. 4a-60a. Contracts of the state and political subdivisions, other than municipalities, to contain provisions re nondiscrimination on the basis of sexual orientation.

- (a) Every contract to which the state or any political subdivision of the state other than a municipality is a party shall contain the following provisions:
 - (1) The contractor agrees and warrants that in the performance of the contract such contractor will not discriminate or permit discrimination against any person or group of persons on the grounds of sexual orientation, in any manner prohibited by the laws of the United States or of the state of Connecticut, and that employees are treated when employed without regard to their sexual orientation;

**REQUEST FOR BIDS
FOR
AIR EMISSIONS TESTING
AT THE
MID-CONNECTICUT POWER BLOCK FACILITY**

**SECTION 12
BACKGROUND QUESTIONNAIRE**



BACKGROUND QUESTIONNAIRE

This Questionnaire must be completed and properly executed by an individual or business entity submitting a bid/proposal/statement of qualifications to the Connecticut Resources Recovery Authority (such individual or business entity hereinafter referred to as the "Contractor").

Please answer the following questions by placing an "X" in the appropriate box.

	Yes	No
<p>1. Has the Contractor or any of the following ever been the subject of a criminal investigation?</p> <ul style="list-style-type: none"> (a) A principal of the Contractor; (b) An owner of the Contractor; (c) An officer of the Contractor; (d) A partner in the Contractor; (e) A director of the Contractor; or (f) A stockholder of the Contractor holding 50% or more of the stock of the Contractor. <p><i>If you answered "Yes" to Question 1, proceed to Question 1A and, on a separate sheet of paper, state the following: the court in which the investigation is taking or took place; the approximate date the investigation commenced and, if applicable, concluded; the subject matter of the investigation; and the identity of the person or entity involved.</i></p> <p><i>If you answered "No" to Question 1, proceed to Question 2.</i></p>	<input type="checkbox"/>	<input type="checkbox"/>
<p>1A. Has any indictment arisen out of any such investigation?</p> <p><i>If you answered "Yes" to Question 1A, proceed to Question 1B and, on a separate sheet of paper, state the following: the name of the person or entity indicted; and the status of any such indictment.</i></p> <p><i>If you answered "No" to Question 1A, proceed to Question 2.</i></p>	<input type="checkbox"/>	<input type="checkbox"/>
<p>1B. Has any conviction arisen out of any such indictment?</p> <p><i>If you answered "Yes" to Question 1B, proceed to Question 2 and, on a separate sheet of paper, state the following: the name of the person or entity convicted, the sentence imposed and whether or not an appeal of the conviction is pending.</i></p> <p><i>If you answered "No" to Question 1B, proceed to Question 2.</i></p>	<input type="checkbox"/>	<input type="checkbox"/>

<p>2. Has the Contractor or any of the following ever been the subject of a civil investigation¹?</p> <p>(a) A principal of the Contractor; (b) An owner of the Contractor; (c) An officer of the Contractor; (d) A partner in the Contractor; (e) A director of the Contractor; or (f) A stockholder of the Contractor holding 50% or more of the stock of the Contractor.</p> <p><i>If you answered "Yes" to Question 2, proceed to Question 3 and, on a separate sheet of paper, state the following: the court or other forum in which the investigation took or is taking place; the approximate date the investigation commenced and, if applicable, concluded; the subject matter of the investigation; the identity of the person or entity involved; the status of the investigation; and the outcome of the investigation.</i></p> <p><i>If you answered "No" to Question 2, proceed to Question 3.</i></p>	<input type="checkbox"/>	<input type="checkbox"/>
<p>3. Has any entity (e.g., corporation, partnership, etc.) in which any of the following has an ownership interest of 50% or more in such entity ever been the subject of a criminal investigation?</p> <p>(a) A principal of the Contractor; (b) An owner of the Contractor; (c) An officer of the Contractor; (d) A partner in the Contractor; (e) A director of the Contractor; or (f) A stockholder of the Contractor.</p> <p><i>If you answered "Yes" to Question 3, proceed to Question 3A and, on a separate sheet of paper, state the following: the court in which the investigation is taking or took place; the approximate date the investigation commenced and, if applicable, concluded; the subject matter of the investigation; and the identity of the person or entity involved.</i></p> <p><i>If you answered "No" to Question 3, proceed to Question 4.</i></p>	<input type="checkbox"/>	<input type="checkbox"/>
<p>3A. Has any indictment arisen out of any such investigation?</p> <p><i>If you answered "Yes" to Question 3A, proceed to Question 3B and, on a separate sheet of paper, state the following: the name of the person or entity indicted; and the status of any such indictment.</i></p> <p><i>If you answered "No" to question 3A, proceed to Question 4.</i></p>	<input type="checkbox"/>	<input type="checkbox"/>
<p>3B. Has any conviction arisen out of any such indictment?</p> <p><i>If you answered "Yes" to Question 3B, proceed to Question 4 and, on a separate sheet of paper, state the following: the name of the person or entity convicted, the sentence imposed and whether or not an appeal of the conviction is pending.</i></p> <p><i>If you answered "No" to Question 3B, proceed to Question 4.</i></p>	<input type="checkbox"/>	<input type="checkbox"/>

¹ The phrase "civil investigation" means an investigation undertaken by a governmental entity (e.g., federal, state or municipal) that has investigative and enforcement authority (e.g., the Office of the Connecticut Attorney General, the Connecticut Ethics Commission, the Connecticut Elections Enforcement Commission, the federal Securities and Exchange Commission).

<p>4. Has any entity (e.g., corporation, partnership, etc.) in which any of the following has an ownership interest of 50% or more in such entity ever been the subject of a civil investigation¹?</p> <p>(a) A principal of the Contractor; (b) An owner of the Contractor; (c) An officer of the Contractor; (d) A partner in the Contractor; (e) A director of the Contractor; or (f) A stockholder of the Contractor.</p> <p><i>If you answered "Yes" to Question 4, proceed to Question 5 and, on a separate sheet of paper state the following: the court in which the investigation is taking or took place; the approximate date the investigation commenced and, if applicable, concluded; the subject matter of the investigation; the identity of the person or entity involved; the status of the investigation; and the outcome of the investigation..</i></p> <p><i>If you answered "No" to question 4, proceed to Question 5.</i></p>	<input type="checkbox"/>	<input type="checkbox"/>
<p>5. Has the Contractor or any of the following ever been debarred from bidding on, or otherwise applying for, any contract with the State of Connecticut or any other governmental authority?</p> <p>(a) A principal of the Contractor; (b) An owner of the Contractor; (c) An officer of the Contractor; (d) A partner in the Contractor; (e) A director of the Contractor; or (f) A stockholder of the Contractor holding 50% or more of the stock of the Contractor.</p> <p><i>If you answered "Yes" to Question 5, proceed to the Certification on the following page and, on a separate sheet of paper please explain.</i></p> <p><i>If you answered "No" to question 5, proceed to the Certification on the following page.</i></p>	<input type="checkbox"/>	<input type="checkbox"/>

CERTIFICATION

Signature: _____

Name (print/type): _____

Title: _____

State Of: _____

County Of: _____

_____, being fully sworn, deposes and says that he/she is the _____ (Title) of _____ (Firm Name), the Contractor herein, that he/she has provided answers to the foregoing questions on the Contractor's background, and, under the penalty of perjury, certifies that each and every answer is true.

Sworn to before me this _____ day of _____ 20 _____

Notary Public/Commissioner of the Superior Court

**REQUEST FOR BIDS
FOR
AIR EMISSIONS TESTING
AT THE
MID-CONNECTICUT POWER BLOCK FACILITY**

SECTION 13

**SEEC FORM 11
NOTICE TO EXECUTIVE BRANCH STATE
CONTRACTORS AND PROSPECTIVE STATE
CONTRACTORS OF CAMPAIGN
CONTRIBUTION AND SOLICITATION BAN**

NOTICE TO EXECUTIVE BRANCH STATE CONTRACTORS AND PROSPECTIVE STATE CONTRACTORS OF CAMPAIGN CONTRIBUTION AND SOLICITATION BAN

This notice is provided under the authority of Connecticut General Statutes 9-612(g)(2), as amended by P.A. 07-1, and is for the purpose of informing state contractors and prospective state contractors of the following law (italicized words are defined on the following page):

Campaign Contribution and Solicitation Ban

No *state contractor, prospective state contractor, principal of a state contractor or principal of a prospective state contractor*, with regard to a *state contract or state contract solicitation* with or from a state agency in the executive branch or a quasi-public agency or a holder, or principal of a holder of a valid prequalification certificate, shall make a contribution to, or *solicit* contributions on behalf of (i) an exploratory committee or candidate committee established by a candidate for nomination or election to the office of Governor, Lieutenant Governor, Attorney General, State Comptroller, Secretary of the State or State Treasurer, (ii) a political committee authorized to make contributions or expenditures to or for the benefit of such candidates, or (iii) a party committee;

In addition, no holder or principal of a holder of a valid prequalification certificate, shall make a contribution to, or solicit contributions on behalf of (i) an exploratory committee or candidate committee established by a candidate for nomination or election to the office of State senator or State representative, (ii) a political committee authorized to make contributions or expenditures to or for the benefit of such candidates, or (iii) a party committee.

Duty to Inform

State contractors and prospective state contractors are required to inform their principals of the above prohibitions, as applicable, and the possible penalties and other consequences of any violation thereof.

Penalties for Violations

Contributions or solicitations of contributions made in violation of the above prohibitions may result in the following civil and criminal penalties:

Civil penalties--\$2000 or twice the amount of the prohibited contribution, whichever is greater, against a principal or a contractor. Any state contractor or prospective state contractor which fails to make reasonable efforts to comply with the provisions requiring notice to its principals of these prohibitions and the possible consequences of their violations may also be subject to civil penalties of \$2000 or twice the amount of the prohibited contributions made by their principals.

Criminal penalties—Any knowing and willful violation of the prohibition is a Class D felony, which may subject the violator to imprisonment of not more than 5 years, or \$5000 in fines, or both.

Contract Consequences

Contributions made or solicited in violation of the above prohibitions may result, in the case of a state contractor, in the contract being voided.

Contributions made or solicited in violation of the above prohibitions, in the case of a prospective state contractor, shall result in the contract described in the state contract solicitation not being awarded to the prospective state contractor, unless the State Elections Enforcement Commission determines that mitigating circumstances exist concerning such violation.

The State will not award any other state contract to anyone found in violation of the above prohibitions for a period of one year after the election for which such contribution is made or solicited, unless the State Elections Enforcement Commission determines that mitigating circumstances exist concerning such violation.

Additional information and the entire text of P.A 07-1 may be found on the website of the State Elections Enforcement Commission, www.ct.gov/seec. Click on the link to "State Contractor Contribution Ban."

Definitions:

"State contractor" means a person, business entity or nonprofit organization that enters into a state contract. Such person, business entity or nonprofit organization shall be deemed to be a state contractor until December thirty-first of the year in which such contract terminates. "State contractor" does not include a municipality or any other political subdivision of the state, including any entities or associations duly created by the municipality or political subdivision exclusively amongst themselves to further any purpose authorized by statute or charter, or an employee in the executive or legislative branch of state government or a quasi-public agency, whether in the classified or unclassified service and full or part-time, and only in such person's capacity as a state or quasi-public agency employee.

"Prospective state contractor" means a person, business entity or nonprofit organization that (i) submits a response to a state contract solicitation by the state, a state agency or a quasi-public agency, or a proposal in response to a request for proposals by the state, a state agency or a quasi-public agency, until the contract has been entered into, or (ii) holds a valid prequalification certificate issued by the Commissioner of Administrative Services under section 4a-100. "Prospective state contractor" does not include a municipality or any other political subdivision of the state, including any entities or associations duly created by the municipality or political subdivision exclusively amongst themselves to further any purpose authorized by statute or charter, or an employee in the executive or legislative branch of state government or a quasi-public agency, whether in the classified or unclassified service and full or part-time, and only in such person's capacity as a state or quasi-public agency employee.

"Principal of a state contractor or prospective state contractor" means (i) any individual who is a member of the board of directors of, or has an ownership interest of five per cent or more in, a state contractor or prospective state contractor, which is a business entity, except for an individual who is a member of the board of directors of a nonprofit organization, (ii) an individual who is employed by a state contractor or prospective state contractor, which is a business entity, as president, treasurer or executive vice president, (iii) an individual who is the chief executive officer of a state contractor or prospective state contractor, which is not a business entity, or if a state contractor or prospective state contractor has no such officer, then the officer who duly possesses comparable powers and duties, (iv) an officer or an employee of any state contractor or prospective state contractor who has *managerial or discretionary responsibilities with respect to a state contract*, (v) the spouse or a *dependent child* who is eighteen years of age or older of an individual described in this subparagraph, or (vi) a political committee established or controlled by an individual described in this subparagraph or the business entity or nonprofit organization that is the state contractor or prospective state contractor.

"State contract" means an agreement or contract with the state or any state agency or any quasi-public agency, let through a procurement process or otherwise, having a value of fifty thousand dollars or more, or a combination or series of such agreements or contracts having a value of one hundred thousand dollars or more in a calendar year, for (i) the rendition of services, (ii) the furnishing of any goods, material, supplies, equipment or any items of any kind, (iii) the construction, alteration or repair of any public building or public work, (iv) the acquisition, sale or lease of any land or building, (v) a licensing arrangement, or (vi) a grant, loan or loan guarantee. "State contract" does not include any agreement or contract with the state, any state agency or any quasi-public agency that is exclusively federally funded, an education loan or a loan to an individual for other than commercial purposes.

"State contract solicitation" means a request by a state agency or quasi-public agency, in whatever form issued, including, but not limited to, an invitation to bid, request for proposals, request for information or request for quotes, inviting bids, quotes or other types of submittals, through a competitive procurement process or another process authorized by law waiving competitive procurement.

"Managerial or discretionary responsibilities with respect to a state contract" means having direct, extensive and substantive responsibilities with respect to the negotiation of the state contract and not peripheral, clerical or ministerial responsibilities.

"Dependent child" means a child residing in an individual's household who may legally be claimed as a dependent on the federal income tax of such individual.

"Solicit" means (A) requesting that a contribution be made, (B) participating in any fund-raising activities for a candidate committee, exploratory committee, political committee or party committee, including, but not limited to, forwarding tickets to potential contributors, receiving contributions for transmission to any such committee or bundling contributions, (C) serving as chairperson, treasurer or deputy treasurer of any such committee, or (D) establishing a political committee for the sole purpose of soliciting or receiving contributions for any committee. Solicit does not include: (i) making a contribution that is otherwise permitted by Chapter 155 of the Connecticut General Statutes; (ii) informing any person of a position taken by a candidate for public office or a public official, (iii) notifying the person of any activities of, or contact information for, any candidate for public office; or (iv) serving as a member in any party committee or as an officer of such committee that is not otherwise prohibited in this section.

**REQUEST FOR BIDS
FOR
AIR EMISSIONS TESTING
AT THE
MID-CONNECTICUT POWER BLOCK FACILITY**

**SECTION 14
NOTICE OF AWARD**



NOTICE OF AWARD

TO: [NAME OF CONTACT FOR SUCCESSFUL BIDDER]
[NAME OF SUCCESSFUL BIDDER]
[ADDRESS 1 OF SUCCESSFUL BIDDER]
[ADDRESS 2 OF SUCCESSFUL BIDDER]

PROJECT: Mid-Connecticut

RFQ NUMBER: 12-EN-001

CONTRACT: Agreement for Air Emissions Testing at the Mid-Connecticut Power Block Facility

The Connecticut Resources Recovery Authority (“CRRA”) has considered the Bid submitted by you dated [DATE] in response to CRRA’s Notice To Contractors – Invitation To Bid for air emissions testing services at the Mid-Connecticut Power Block Facility, which services are more particularly described in the “Agreement for Air Emissions Testing at the Mid-Connecticut Power Block Facility (the “Services”).

You are hereby notified that your Bid has been accepted for performing the Services from time to time as the same may be requested by CRRA.

Within ten (10) days from the date of this Notice of Award you are required to:

- (a) Execute the two attached counterparts of the non-negotiable Agreement and deliver such executed counterparts to CRRA. Such execution includes
 - (1) Entering the requested information in the “Notices” Section (Section 7.7, Page 20) of the Agreement,
 - (2) Signing the Agreement (Page 22),
 - (3) Printing the signer’s name under the signature line (Page 22) and
 - (4) Printing the signer’s title following the word “Its” (Page 22);
- (b) Execute the attached Contractor’s Certification Concerning Gifts and deliver such executed Certification to CRRA;

- (c) Execute the attached Affidavit Concerning Consulting Fees and deliver such executed Affidavit to CRRA;
- (d) Deliver to CRRA the requisite certificate(s) of insurance as specified in Article 6 of the Agreement [Please be advised that this is the area in which Consultants seem to have the most difficulty. CRRA requires that the certificate submitted show evidence of exactly the insurance requirements specified in the Agreement.];
- (e) Complete and deliver to CRRA the attached Form W-9, "Request for Taxpayer Identification Number and Certification;" and
- (f) If the remittance address/contact information for the Services is different from the address/contact information indicated on Page 1 of this "Notice of Award," provide such remittance address/contact information in the following table;

Contractor Name:	
Remittance Contact:	
Title:	
Street Address:	
Street Address:	
City, State, Zip Code	
Telephone Number:	
Fax Number:	
E-Mail Address:	

- (g) Satisfy all other conditions set forth herein.

As you have agreed, the terms and conditions of the Agreement, as attached, are non-negotiable.

If you fail within ten (10) days from the date of this Notice Of Award to perform and complete any of your obligations set forth in items (a) through (g) above, CRRA will be entitled to consider all your rights arising out of CRRA's acceptance of your Bid as abandoned and terminated. CRRA will also be entitled to such other rights and remedies as may be granted at law or in equity.

You are required to acknowledge your receipt of this Notice Of Award by signing below and returning the same to CRRA at the following address:

Connecticut Resources Recovery Authority
100 Constitution Plaza, 6th Floor
Hartford, Connecticut 06103
Attention: Ronald Gingerich

Dated this [DAY] day of [MONTH], [YEAR].

Connecticut Resources Recovery Authority

By: _____
Ronald Gingerich
Title: Development Manager

ACCEPTANCE OF NOTICE

Receipt of this NOTICE OF AWARD is hereby acknowledged this _____ day of _____, 20__.

By:

Signature: _____

Name (print/type): _____

Title: _____

ATTACHMENT A
To
NOTICE OF AWARD

CONTRACTOR'S CERTIFICATION
CONCERNING GIFTS



CONTRACTOR'S CERTIFICATION CONCERNING GIFTS

AIR EMISSIONS TESTING AT THE MID-CONNECTICUT POWER BLOCK FACILITY

(This CERTIFICATION is to be signed by an authorized officer of the Contractor or the Contractor's managing general partner.)

Section 4-252 of the *Connecticut General Statutes* requires that a Contractor (i.e., the successful bidder/proposer/statement of qualifications submitter for an Agreement) complete and properly execute this Certification Concerning Gifts at the same time that the Contractor executes the Agreement. If the Contractor fails to make the required certifications, the Contractor shall be disqualified for the Agreement.

I, _____, a duly authorized officer and/or representative of _____ (firm name) (the "Contractor"), being duly sworn, hereby depose and say that:

1. I am over eighteen (18) years of age and believe in the obligations of an oath; and
2. The Contractor has submitted a bid/proposal/statement of qualifications for the "Agreement for Air Emissions Testing at the Mid-Connecticut Power Block Facility" (the "Agreement") to the Connecticut Resources Recovery Authority ("CRRA"), has been selected by CRRA as the successful bidder/proposer/statement of qualifications submitter for the Agreement and is prepared to enter into the Agreement with CRRA; and
3. No gifts were made between March 1, 2011 and the date of execution of the Agreement, by
 - (a) The Contractor,
 - (b) Any principals and key personnel of the Contractor who participated substantially in preparing the Contractor's bid/proposal/statement of qualifications for or the negotiation of the Agreement, or
 - (c) Any agent of the Contractor or principals and key personnel who participated substantially in preparing the Contractor's bid/proposal/statement of qualifications for or the negotiation of the Agreementto
 - (1) Any public official or employee of CRRA who participated substantially in the preparation of the bid/proposal/qualifications solicitation for or the negotiation or award of the Agreement (such CRRA employees are listed in Table 2 below), or
 - (2) Any public official or state employee of any state agency who has supervisory or appointing authority over CRRA (such public officials and state employees are listed in Table 3 below); and
4. No such principals and key personnel of the Contractor or agent of the Contractor or principals and key personnel knows of any action by Contractor to circumvent the prohibition on gifts by providing for any other principals and key personnel, official, employee or agent of the Contractor to provide a gift to any such public official or state employee; and

5. The Contractor made the bid/proposal/statement of qualifications for the Agreement without fraud or collusion with any person;
6. The information set forth herein is true, to the best of my knowledge and belief, subject to the penalties of false statement.

TABLE 2: CRRA Substantial Participants in the Preparation of the Request for Bids/Proposals for the Agreement

Steven Yates, Air Compliance Manager
Peter Egan, Director of Environmental Affairs and Development and Acting Director of Operations

TABLE 3: Public Officials and State Employees of State Agencies Who Have Supervisory or Appointing Authority over CRRA

Governor Dannel P. Malloy
Senator Donald E. Williams, Jr., President Pro Tempore of the Senate
Senator John McKinney, Minority Leader of the Senate
Representative Christopher G. Donovan, Speaker of the House of Representatives
Representative Lawrence F. Cafero, Jr., Minority Leader of the House of Representatives

Signature: _____
 Name (type/print): _____
 Title: _____
 State Of: _____
 County Of: _____

_____, being fully sworn, deposes and says that he/she is the _____ (Title) of _____ (Firm Name), the Contractor herein, that he/she has read the foregoing statement concerning gifts, and, under the penalty of perjury, certifies that each and every part of said statement is true to his/her best knowledge and belief.

Sworn to before me this _____ day of _____ 20 ____

 Notary Public/Commissioner of the Superior Court

For the purposes of this Certification Concerning Gifts, the following terms are defined as follows:

"Gift" means anything of value, which is directly and personally received, unless consideration of equal or greater value is given in return. "Gift" shall **not** include:

- (1) A political contribution otherwise reported as required by law or a donation or payment as described in subdivision (9) or (10) of subsection (b) of section 9-333b of the *Connecticut General Statutes*;
- (2) Services provided by persons volunteering their time, if provided to aid or promote the success or defeat of any political party, any candidate or candidates for public office or the position of convention delegate or town committee member or any referendum question;
- (3) A commercially reasonable loan made on terms not more favorable than loans made in the ordinary course of business;
- (4) A gift received from (A) an individual's spouse, fiance or fiancée, (B) the parent, brother or sister of such spouse or such individual, or (C) the child of such individual or the spouse of such child;
- (5) Goods or services (A) which are provided to the state (i) for use on state property, or (ii) to support an event or the participation by a public official or state employee at an event, and (B) which facilitate state action or functions. As used in this Affidavit Concerning Gifts, "state property" means (i) property owned by the state, or (ii) property leased to an agency in the Executive or Judicial Department of the state;
- (6) A certificate, plaque or other ceremonial award costing less than one hundred dollars;
- (7) A rebate, discount or promotional item available to the general public;
- (8) Printed or recorded informational material germane to state action or functions;
- (9) Food or beverage or both, costing less than fifty dollars in the aggregate per recipient in a calendar year, and consumed on an occasion or occasions at which the person paying, directly or indirectly, for the food or beverage, or his representative, is in attendance;
- (10) Food or beverage or both, costing less than fifty dollars per person and consumed at a publicly noticed legislative reception to which all members of the General Assembly are invited and which is hosted not more than once in any calendar year by a lobbyist or business organization. For the purposes of such limit, (A) a reception hosted by a lobbyist who is an individual shall be deemed to have also been hosted by the business organization which he owns or is employed by, and (B) a reception hosted by a business organization shall be deemed to have also been hosted by all owners and employees of the business organization who are lobbyists. In making the calculation for the purposes of such fifty-dollar limit, the donor shall divide the amount spent on food and beverage by the number of persons whom the donor reasonably expects to attend the reception;
- (11) Food or beverage or both, costing less than fifty dollars per person and consumed at a publicly noticed reception to which all members of the General Assembly from a region of the state are

invited and which is hosted not more than once in any calendar year by a lobbyist or business organization. For the purposes of such limit, (A) a reception hosted by a lobbyist who is an individual shall be deemed to have also been hosted by the business organization which he owns or is employed by, and (B) a reception hosted by a business organization shall be deemed to have also been hosted by all owners and employees of the business organization who are lobbyists. In making the calculation for the purposes of such fifty-dollar limit, the donor shall divide the amount spent on food and beverage by the number of persons whom the donor reasonably expects to attend the reception. As used in this subdivision, "region of the state" means the established geographic service area of the organization hosting the reception;

- (12) Gifts costing less than one hundred dollars in the aggregate or food or beverage provided at a hospitality suite at a meeting or conference of an interstate legislative association, by a person who is not a registrant or is not doing business with the state of Connecticut;
- (13) Admission to a charitable or civic event, including food and beverage provided at such event, but excluding lodging or travel expenses, at which a public official or state employee participates in his official capacity, provided such admission is provided by the primary sponsoring entity;
- (14) Anything of value provided by an employer of (A) a public official, (B) a state employee, or (C) a spouse of a public official or state employee, to such official, employee or spouse, provided such benefits are customarily and ordinarily provided to others in similar circumstances; or
- (15) Anything having a value of not more than ten dollars, provided the aggregate value of all things provided by a donor to a recipient under this subdivision in any calendar year shall not exceed fifty dollars.

"Participated substantially" means participation that is direct, extensive and substantive, and not peripheral, clerical or ministerial.

"Principals and key personnel" means officers, directors, shareholders, members, partners and managerial employees.

ATTACHMENT B
To
NOTICE OF AWARD

**AFFIDAVIT CONCERNING CONSULTING
FEES**



**AFFIDAVIT CONCERNING
CONSULTING FEES**

Pursuant to Section 4a-81 of the Connecticut General Statutes, this Affidavit must be completed and properly executed under penalty of false statement by a chief official of the successful bidder/proposer/statement of qualifications submitter for an Agreement (the "Contractor"). Such chief official of the Contractor must be the person who is properly authorized to execute the Agreement on behalf of the Contractor. This Affidavit must be properly executed at the same time that the Contractor executes the Agreement. If the Contractor fails to execute this Affidavit, the Contractor shall be disqualified for the Agreement.

I, the undersigned, am over the age of eighteen and understand and appreciate the obligation of an oath. I am _____ (title) of _____ (firm name), an entity duly formed and existing under the laws of _____ (name of state or commonwealth) ("Contractor").

I certify that I am authorized to execute and deliver this affidavit on behalf of Contractor, as follows:

1. Contractor seeks to enter into the "Agreement for Air Emissions Testing at the Mid-Connecticut Power Block Facility" (the "Agreement") with the Connecticut Resources Recovery Authority ("CRRA");
2. Except as disclosed in Table 1 below and except for a consulting agreement that is with a consultant who is registered under the provisions of Chapter 10 of the Connecticut General Statutes¹ as of the date this Affidavit is submitted, Contractor has not entered into any consulting agreement² in connection with the Agreement whereby any duties of the consultant pursuant to said consulting agreement² require that consultant pursue communications concerning business of CRRA, whether or not direct contact with CRRA, a CRRA official, a CRRA employee, a state agency, a state or public official, or a state employee was expected or made;
3. Contractor shall amend this Affidavit whenever Contractor enters into any new consulting agreement² during the term of the Agreement; and
4. The statements set forth herein are true, to the best of my knowledge and belief, subject to the penalties of false statement.

¹ Pursuant to Section 1-94 of Chapter 10 the Connecticut General Statutes, a lobbyist as defined in the Chapter is required to register with the Office of State Ethics.

² Pursuant to Section 41-81 of the Connecticut General Statutes, for the purposes of this Affidavit, "consulting agreement" means "any written or oral agreement to retain the services, for a fee, of a consultant for the purposes of (A) providing counsel to a contractor, vendor, consultant or other entity seeking to conduct, or conducting, business with the state, (B) contacting, whether in writing or orally, any executive, judicial, or administrative office of the state, including any department, institution, bureau, board, commission, authority, official or employee for the purpose of solicitation, dispute resolution, introduction, requests for information, or (C) any other similar activity related to such contract. Consulting agreement does not include any agreements entered into with a consultant who is registered under the provisions of chapter 10 as of the date such affidavit is submitted in accordance with the provisions of this section.

TABLE 1: Disclosure of Consulting Agreements

(If Contractor has not entered into any consulting agreements² in connection with the Agreement, Contractor should enter "None" in the space provided for the "Name of Consultant.")

Name of Consultant:	
Name of Consultant's Firm:	
Description of the Basic Terms of the Consulting Agreement:	
Brief Description of the Services Provided:	
Is the Consultant a Former State Employee or Public Official?	<input type="checkbox"/> Yes <input type="checkbox"/> No
If the answer to the question above concerning whether or not the consultant is a former state employee or public official is "Yes," the following information must be provided.	
Name of Former Agency:	
Date Employment Terminated:	

By (Signature): _____

Name (Print): _____

Title: _____

Sworn to before me this _____ day of _____ 20 _____

Notary Public/Commissioner of the Superior Court

Commission Expiration Date

**REQUEST FOR BIDS
FOR
AIR EMISSIONS TESTING
AT THE
MID-CONNECTICUT POWER BLOCK FACILITY**

SECTION 15

**AGREEMENT FOR
AIR EMISSIONS TESTING
AT THE
MID-CONNECTICUT POWER BLOCK
FACILITY**

**AGREEMENT
FOR
AIR EMISSIONS TESTING
AT THE
MID-CONNECTICUT POWER BLOCK
FACILITY**

BETWEEN

**CONNECTICUT RESOURCES
RECOVERY AUTHORITY**

AND

[NAME OF CONTRACTOR]

Dated as of _____, 2011

AIR EMISSIONS TESTING AT THE MID-CONNECTICUT POWER BLOCK FACILITY AGREEMENT

CONTENTS

PRELIMINARY STATEMENT	3
1. DEFINITIONS, CONSTRUCTION AND INTERPRETATION	3
1.1 Definitions	3
1.2 Construction And Interpretation	4
2. SCOPE OF SERVICES	5
2.1 Contractor's Responsibilities	5
2.2 Performance and Completion of Services	6
2.3 CRRA's Responsibilities	6
2.4 Direction of Services	6
2.5 CRRA's Inspection Rights	7
2.6 Access	7
2.7 Change in Scope of Services	7
2.8 Site and Subsurface Conditions	8
2.9 Proprietary Information	8
2.10 Books and Records	8
2.11 Status of Contractor	9
2.12 Subcontractors	9
2.13 Contractor's Employees	9
2.14 Mechanic's Liens	9
3. COMPENSATION AND PAYMENT	10
3.1 Compensation	10
3.2 Payment Procedure	11
3.3 Accounting Obligations	12
3.4 Withholding Taxes And Other Payments	12
3.5 State of Connecticut Taxes	12
4. TERM OF AGREEMENT	13
4.1 Term	13
4.2 Time is of the Essence	13
4.3 Termination	14
4.4 Restoration	14
5. INDEMNIFICATION	15
5.1 Contractor's Indemnity	15
6. INSURANCE	15
6.1 Required Insurance	15
6.2 Deductibles and Self-Insured Retentions	16
6.3 Other Insurance Provisions	16
6.4 Acceptability of Insurance	17
6.5 Verification of Coverage	17
6.6 Subcontractors	17
7. MISCELLANEOUS	18
7.1 Non-Discrimination	18
7.2 Entire Agreement	19
7.3 Governing Law	19
7.4 Assignment	19
7.5 No Waiver	19
7.6 Modification	19

7.7	Notices.....	19
7.8	Benefit and Burden.....	20
7.9	Severability.....	20
7.10	Counterparts.....	20
7.11	Whistleblower Protection.....	20
7.12	Campaign Contribution And Solicitation Prohibitions.....	21
7.13	Affidavit Concerning Nondiscrimination.....	21
7.14	Affidavit Concerning Consulting Fees.....	21
7.15	Contractor's Certification Concerning Gifts.....	21
7.16	President's Certification Concerning Gifts.....	21

- EXHIBIT A: Scope Of Services
- EXHIBIT B: Compensation Schedule
- EXHIBIT C: CRRA's Travel and Expense Reporting Policy and Procedure
- EXHIBIT D: Monthly Bill Format
- EXHIBIT E: SEEC Form 11, Notice To Executive Branch State Contractors And Prospective
State Contractors Of Campaign Contribution And Solicitation Ban
- EXHIBIT F: Affidavit Concerning Nondiscrimination
- EXHIBIT G: Affidavit Concerning Consulting Fees
- EXHIBIT H: Contractor's Certification Concerning Gifts
- EXHIBIT I: CRRA President's Certification Concerning Gifts

This **AGREEMENT FOR AIR EMISSIONS TESTING AT THE MID-CONNECTICUT POWER BLOCK FACILITY** (the "Agreement") is made and entered into as of this _____ day of _____, 2011 by and between the **CONNECTICUT RESOURCES RECOVERY AUTHORITY**, a body politic and corporate, constituting a public instrumentality and political subdivision of the State of Connecticut, having its principal offices at 100 Constitution Plaza, 6th Floor, Hartford, Connecticut 06103 (hereinafter "CRRA" or "Owner") and [NAME OF CONTRACTOR], having its principal offices at [ADDRESS OF CONTRACTOR] (hereinafter "Contractor").

PRELIMINARY STATEMENT

WHEREAS CRRA owns a certain parcel of real property located at 1 Reserve Road, Gate 20 in Hartford, Connecticut, upon which property CRRA operates the Mid-Connecticut Power Block Facility.

WHEREAS CRRA now desires to enter into this Agreement with Contractor in order for Contractor to perform air emissions testing at the Mid-Connecticut Power Block Facility within the boundaries of the Property, and other related work, in accordance with the Contract Documents.

NOW, THEREFORE, in consideration of the mutual covenants, promises, and representations contained herein, and for other good and valuable consideration, the receipt and sufficiency of which are hereby acknowledged, the parties hereto agree as follows.

1. DEFINITIONS, CONSTRUCTION AND INTERPRETATION

1.1 Definitions

As used in this Agreement and in other Contract Documents (as defined herein) the following terms shall have the meanings as set forth below:

1.1.1 Addenda

"Addenda" means written or graphic documents issued prior to the bid due date, which clarify, correct or change any or all of the Contract Documents.

1.1.2 Contract Documents

"Contract Documents" means this Agreement (including all exhibits attached hereto), the RFB Package Documents, Addenda, Contractor's bid (including all documentation accompanying such bid, all other documentation submitted in connection with such bid, and all post-bid documentation submitted prior to the Notice Of Award), the Notice Of Award, the Notice To Proceed (as defined herein), any written amendments to any of the Contract Documents and any change order issued pursuant to the Contract Documents.

1.1.3 Effective Date

“Effective Date” means the date set forth above in this Agreement.

1.1.4 Laws And Regulations

“Laws And Regulations” means any and all applicable current or future laws, rules, regulations, ordinances, codes, orders and permits of any and all federal, state and local governmental and quasi-governmental bodies, agencies, authorities and courts having jurisdiction.

1.1.5 Power Block Facility

“Power Block Facility” means the Mid-Connecticut Power Block Facility which CRRA operates on the Property.

1.1.6 Project

“Project” means all of the Services associated with this Agreement.

1.1.7 Property

“Property” means the certain parcel of real property owned by CRRA and located at 1 Reserve Road, Gate 20, in Hartford, Connecticut.

1.1.8 Site

“Site” means those areas of the Property upon which the Services are to be performed, furnished and completed by Contractor in accordance with the Contract Documents.

1.2 Construction And Interpretation

For purposes of this Agreement:

- (a) Capitalized terms used herein shall have the meanings set forth herein;
- (b) Whenever nouns or pronouns are used in this Agreement, the singular shall mean the plural, the plural shall mean the singular, and any gender shall mean all genders or any other gender, as the context may require;
- (c) Words that have well-known technical or trade meanings are used herein in accordance with such recognized meanings unless otherwise specifically provided;
- (d) All accounting terms not otherwise defined herein have the meanings assigned to them in accordance with “generally accepted accounting principles,” and the term “generally accepted accounting principles” with respect to any computation required or permitted hereunder shall mean such accounting principles that are generally accepted as of the Effective Date of this Agreement;

- (e) The words “herein”, “hereof” and “hereunder” and words of similar import refer to this Agreement as a whole and not to any particular Article, Section or Sub-section;
- (f) Reference to any particular party shall include that party’s employees and the authorized agents of that party;
- (g) All references to agreements are references to the agreements as the provisions thereof that may be amended, modified or waived from time to time; and,
- (h) The captions contained in this Agreement have been inserted for convenience only and shall not affect or be effective to interpret, change or restrict the terms of provisions of this Agreement.

2. SCOPE OF SERVICES

2.1 Contractor’s Responsibilities

Contractor shall be responsible for furnishing all labor, materials, supplies, tools, equipment and other facilities and necessary appurtenances or property for or incidental to the Project and the performance and completion of the Services (as hereinafter defined). The Services will involve, but not be limited to, the following:

- (a) Air emissions testing at the Mid-Connecticut Power Block Facility, including, but not limited to, the following:
 - (1) Preparation of a test protocol and “Intent To Test” documentation acceptable to the Connecticut Department of Environmental Protection (“CTDEP”);
 - (2) Mobilization, set-up, emissions testing, demobilization;
 - (3) Laboratory testing of all samples; and
 - (4) Preparation of a final report acceptable to the CTDEP.
- (b) All other work required to complete the Project;
- (c) Performing all of such activities in accordance with and as required by the Contract Documents, including but not limited to, the Scope Of Services set forth in **Exhibit A** (the “Scope of Services”) which is attached hereto and made a part hereof;
- (d) Restoring any part of the Property, the improvements thereon, or the Services (as hereinafter defined) that require restoration pursuant to the terms and conditions in Section 4.4 hereof; and

- (e) Making all required notifications and obtaining all local, state, and federal permits and approvals necessary for the completion of the Services.

Items (a) through (e) above are hereinafter collectively referred to as the "Services."

2.2 Performance and Completion of Services

All Services shall be performed and completed by Contractor in a good workmanlike manner consistent and in accordance with:

- (a) Any and all instructions, guidance and directions provided by CRRA to Contractor;
- (b) The Contract Documents;
- (c) Sound air emissions testing practices;
- (d) The highest industry standards applicable to Contractor and its performance of the Services hereunder;
- (e) The schedule for the Services set forth in **Exhibit A** attached hereto and made a part hereof; and
- (f) All Laws And Regulations.

Items (a) through (f) above are hereinafter collectively referred to as the "Standards."

Contractor shall obtain any locally required building or other permits required for the Services, and Contractor shall also assist and fully cooperate with CRRA in obtaining any other applicable permits necessary to begin and complete the Services.

2.3 CRRA's Responsibilities

CRRA shall be responsible for administering this Agreement, accepting the Services that are performed and completed by Contractor in accordance with the Contract Documents, and receiving and paying invoices for such Services.

2.4 Direction of Services

CRRA may, where necessary or desired, provide Contractor with instructions, guidance and directions in connection with Contractor's performance of the Services hereunder. CRRA reserves the right to determine whether Contractor will, upon completion of any phase of the Services, proceed to any or all remaining phases of the Services. If CRRA determines that Contractor shall not proceed with the remaining Services, CRRA shall terminate this Agreement in accordance with Section 4.3 hereof.

2.5 CRRA's Inspection Rights

Contractor's performance of the Services hereunder, as well as Contractor's work products resulting from such performance, are subject to inspection by CRRA. Inspections may be conducted at any time by CRRA. In the event of an inspection, Contractor shall provide to CRRA any documents or other materials that may be necessary in order for CRRA to conduct the inspection. If, after any such inspection, CRRA is unsatisfied with Contractor's performance of the Services hereunder or any of the work products resulting therefrom, Contractor shall, at the direction of CRRA, render such performance or work products satisfactory to CRRA at no additional cost or expense to CRRA and without any extension of or addition to any Contract Time for the remaining Services. For purpose of this Section 2.5, CRRA shall mean CRRA and/or its authorized agents.

2.6 Access

CRRA hereby grants to Contractor, during such times as directed by CRRA, access to only those areas of the Property necessary for Contractor to perform the Services hereunder, provided that:

- (a) Contractor shall not interfere with any other operations or activities being conducted on the Property by either CRRA or any other person or entity;
- (b) Contractor directly coordinates with CRRA on such access and Contractor's storage of any equipment or materials on the Property; and
- (c) Contractor is in compliance with all of the terms and conditions of this Agreement.

CRRA reserves the right to revoke the access granted to Contractor herein if Contractor fails to comply with any of the foregoing conditions of access.

2.7 Change in Scope of Services

In the event that CRRA determines during the term of this Agreement that any revisions, modifications or changes are necessary to the Scope Of Services as set forth in Section 2.1 hereof, then pursuant to CRRA's request, Contractor shall promptly commence and perform the services required for such revisions, modifications or changes, which services shall be performed in accordance with the Standards unless otherwise specifically agreed to in writing by CRRA and Contractor. If any adjustment(s) to the Contract Price and/or the Contract Time is required as a result of such revisions, modifications or changes, CRRA and Contractor shall mutually agree in writing on the amount of such adjustment(s) provided that the schedule of values (including the unit prices set forth therein) approved by CRRA for the Project, to the extent applicable, shall be used to determine the appropriate increase or decrease in the quantity or cost of the materials or Services necessitated by such revisions, modifications or changes. Contractor shall promptly commence and perform any work required by such revisions, modifications or changes even if CRRA and Contractor cannot agree on the amount of such adjustment(s). If Contractor determines that a change in scope is

necessary to complete the Services, Contractor shall notify CRRA in writing within three (3) business days.

2.8 Site and Subsurface Conditions

All information and data shown or indicated in the Contract Documents with respect to underground facilities, surface conditions, subsurface conditions or other conditions at or contiguous to the Site are furnished for information only and CRRA does not assume any responsibility for the accuracy or completeness of such information and data. Contractor acknowledges and agrees that CRRA does not assume any responsibility for such information and data and that Contractor is solely responsible for investigating and satisfying itself as to all actual and existing Site conditions, including but not limited to surface conditions, subsurface conditions and underground facilities. Contractor has carefully studied all such information and data and Contractor has obtained and carefully studied (or assumes responsibility for having done so) all such additional or supplementary examinations, investigations, explorations, tests, studies and data concerning conditions (including but not limited to surface conditions, subsurface conditions and underground facilities) at or contiguous to the Site and all other conditions or factors which may affect cost, progress, performance, furnishing or completion of the Services or which relate to any aspect of the means, methods, techniques, sequences, and procedures of construction or performance of the Services to be employed by Contractor and safety precautions and programs incident thereto. Contractor does not consider that any additional examinations, investigations, explorations, tests, studies or data are necessary for Contractor to conclusively determine, and Contractor has so determined, that the Services can be performed, furnished and completed in accordance with the Contract Time, the Contract Price and the other terms and conditions of the Contract Documents. In the event that the information or data shown or indicated in the Contract Documents with respect to underground facilities or surface, subsurface or other conditions at or contiguous to the Site differs from conditions encountered by Contractor during performance of the Services, there shall be no increase in the Contract Price and/or no extension of the Contract Time as a result of such differing conditions, unless CRRA, in its sole and absolute discretion, agrees in writing to such increase and/or extension.

2.9 Proprietary Information

Contractor shall not use, publish, distribute, sell or divulge any information obtained from CRRA by virtue of this Agreement for Contractor's own purposes or for the benefit of any person, firm, corporation or other entity (other than CRRA) without the prior written consent of CRRA. Any report or other work product prepared by Contractor in connection with the performance of the Services hereunder shall be owned solely and exclusively by CRRA and cannot be used by Contractor for any purpose beyond the scope of this Agreement without the prior written consent of CRRA.

2.10 Books and Records

Contractor shall maintain proper books and records containing complete and correct information on all Services performed by Contractor pursuant to this Agreement in accordance

with generally accepted accounting principles and practices. CRRA has the right to inspect and review all such books and records during Contractor's business hours.

2.11 Status of Contractor

CRRA and Contractor acknowledge and agree that Contractor is acting as an independent contractor in performing any Services for CRRA hereunder and that Contractor shall perform such Services in its own manner and method subject to the terms of this Agreement. Nothing in this Agreement shall be construed or interpreted as creating a partnership, a joint venture, an agency, a master-servant relationship, an employer-employee relationship or any other relationship between CRRA and Contractor other than that of an owner and an independent contractor. Contractor is expressly forbidden from transacting any business in the name of or on account of CRRA, and Contractor has no power or authority to assume or create any obligation or responsibility for or on behalf of CRRA in any manner whatsoever.

2.12 Subcontractors

Contractor shall consult with CRRA and obtain its approval before hiring any subcontractors to perform any Services hereunder. Contractor shall require all of its subcontractors to abide by the terms and conditions of this Agreement. Moreover, Contractor's subcontracts with such subcontractors shall specifically provide that, in the event of a default by Contractor thereunder or under this Agreement, CRRA may directly enforce such subcontracts and make payments thereunder. Contractor shall provide CRRA with all contracts, amendments, books, records, accounts, correspondence and other materials necessary to enforce such subcontracts. Also Contractor's subcontracts with its subcontractors shall specifically include CRRA as a third party beneficiary and shall provide that such subcontractors shall not be excused from any of their obligations under such subcontracts by reason of any claims, setoffs, or other rights whatsoever that they may have with or against Contractor other than through such subcontracts.

2.13 Contractor's Employees

All persons employed by Contractor shall be subject and responsible solely to the direction of Contractor and shall not be deemed to be employees of CRRA.

2.14 Mechanic's Liens

Contractor shall claim no interest in the Property or any equipment, fixtures or improvements located or to be located thereon, including but not limited to the Site or any part thereof. Contractor shall not file any mechanic's liens or other liens or security interests against CRRA or any of its properties, including but not limited to the Property. Contractor shall defend, indemnify and hold harmless CRRA against all costs associated with the filing of such liens or interests by Contractor or any of its subcontractors or materialmen. Before any subcontractor or materialman of Contractor commences any Services hereunder, Contractor shall deliver to CRRA an original waiver of mechanic's liens properly executed by such subcontractor or materialman. If any mechanic's lien is filed against CRRA or any of its properties in connection with the Services hereunder, Contractor shall cause the same to be canceled and dis-

charged of record within fifteen (15) days after the filing of such lien and, if Contractor fails to do so, CRRA may, at its option but without any obligation to do so, make any payment necessary to obtain such cancellation or discharge and the cost thereof, at CRRA's election, shall be either deducted from any payment due to Contractor hereunder or reimbursed to CRRA promptly upon demand by CRRA to Contractor.

3. COMPENSATION AND PAYMENT

3.1 Compensation

For the Services rendered and expenses incurred under this Agreement, Contractor shall be paid by CRRA on the basis set forth on **Exhibit B** attached hereto and made a part hereof. Contractor shall be reimbursed for costs and expenses actually incurred in providing the Services at the rates specified in the "Payment Rate Schedule" in **Exhibit B**. In no case shall the Contractor be paid more for Task 1 and Task 2 Services than the amount set forth in **Exhibit B** as the "Not-To-Exceed Contract Price."

Contractor will not be paid for costs or expenses for Task 1 and Task 2 Services that exceed the Not-To-Exceed Contract Price of **Exhibit B**. CRRA does not guarantee that the Not-To-Exceed Contract Price of **Exhibit B** or any amount of monies will be paid to Contractor during the term of this Agreement.

For employees who are eligible for and are paid a higher hourly rate for overtime than the hourly rate listed in the "Payment Rate Schedule" of **Exhibit B**, Contractor will be entitled to reimbursement for such employee overtime when such overtime is a result of more than eight (8) hours in one day and/or more than forty (40) hours in one week worked by such an employee on this Project. Such overtime will be reimbursed as provided in **Exhibit B**.

Out-of-pocket expenses shall be reimbursed at cost provided they are consistent with CRRA's Travel and Expense Reporting document attached hereto and made a part hereof as **Exhibit C**, except that Contractor will be deemed to have met CRRA's "Receipt" requirements of such document if Contractor provides to CRRA with each billing the following:

- (a) Receipts for all items greater than or equal to \$25 and
- (b) Copies of Contractor's expense forms itemizing expenses incurred in providing Services to CRRA.

Contractor shall be solely responsible for the reporting of and payment of federal, state and local income taxes, FICA and FUTA contributions and shall maintain any insurance coverage required by state or federal law in addition to any insurance required hereunder.

3.2 Payment Procedure

Contractor shall render a bill to CRRA each month for all of the Services performed and all of the costs and expenses incurred in the immediately preceding month pursuant to this Agreement. Each monthly bill will contain at least the following information.

- (a) The name, title and billing rate for each person performing Services for which payment is sought;
- (b) A description of the Services performed by each person;
- (c) The time spent by each person on the Project;
- (d) Separate listing of all expenses incurred, including copies of receipts or sub-contractor invoices;
- (e) The time period covered by the invoice;
- (f) The contract number for this Agreement (to be provided by CRRA); and
- (g) The request for services identification number, if appropriate.

Exhibit D, attached hereto and made a part hereof, is the format for all monthly bills.

Contractor shall not be compensated for any time spent preparing any billing documentation or related materials.

If CRRA determines, in its sole discretion, that:

- (a) The Services for which Contractor is requesting payment have been properly performed and completed in conformance with the Standards,
- (b) Contractor is not in default hereunder,
- (c) CRRA does not dispute the amount of the payment requested, and
- (d) The bill contains all of the information required hereunder,

then CRRA shall pay the amount requested within thirty (30) calendar days after its receipt of such bill.

If, however, CRRA determines that:

- (a) Any of the Services for which Contractor has requested payment is not in conformance with the Standards,
- (b) Such bill does not contain all the requisite information, or
- (c) Contractor is in default hereunder,

then CRRA may in its sole and absolute discretion withhold all or a portion of the payment requested by Contractor, and Contractor shall, if requested by CRRA, immediately take, at Contractor's sole cost and expense, all action necessary to render such Services and/or bill in conformance with the Standards, or to cure such default.

CRRA shall have no obligation under this Agreement to pay for any Services that CRRA determines have not been performed and/or completed in conformance with the Standards, and CRRA shall have no obligation to pay Contractor any amount due Contractor under this Agreement if Contractor is in default hereunder. If CRRA disputes the amount in any written request for payment submitted by Contractor, CRRA shall have the right to withhold the disputed amount until the dispute is settled. CRRA shall notify Contractor of any disputed amount and the reason(s) for disputing such amount.

3.3 Accounting Obligations

Contractor shall maintain books and accounts of the costs incurred by Contractor in performing the Services pursuant to this Agreement by contract number and in accordance with generally accepted accounting principles and practices. CRRA, during normal business hours, for the duration of this Agreement, shall have access to such books and accounts to the extent required to verify such costs incurred.

3.4 Withholding Taxes And Other Payments

No FICA (social security) payroll tax, state or federal income tax, federal unemployment tax or insurance payments, state disability tax or insurance payments or state unemployment tax or insurance payments shall be paid or deposited by CRRA with respect to Contractor, nor be withheld from payment to Contractor by CRRA. No workers' compensation insurance has been or will be obtained by CRRA on account of the Services to be performed hereunder by Contractor, or any of Contractor's employees or subcontractors. Contractor shall be responsible for paying or providing for all of the taxes, insurance and other payments described or similar to those described in this Section 3.4 and Contractor hereby agrees to indemnify CRRA and hold CRRA harmless against any and all such taxes, insurance or payments, or similar costs which CRRA may be required to pay in the event that Contractor's status hereunder is determined to be other than that of an independent contractor.

3.5 State of Connecticut Taxes

Pursuant to Section 22a-270 of the *Connecticut General Statutes* (as the same may be amended or superseded from time to time), CRRA is exempt from all State of Connecticut taxes and assessments ("Connecticut Taxes"), and the payment thereof. Without limiting the generality of the preceding sentence, the sale of any services or tangible personal property to be incorporated into or otherwise consumed in the operation of a CRRA Project is exempt from Connecticut Taxes, including without limitation Connecticut sales and use taxes, wherever purchased. Accordingly, Contractor shall not include in the fees, and Contractor shall not charge or pass through any Connecticut Taxes to CRRA, including that portion of any combined tax or assessment representing any Connecticut Taxes, regardless of whether Contractor has incurred any Connecticut State Taxes in its performance of the Agreement.

CRRA expresses no opinion as to the eligibility for any tax exemption, or refund or other reimbursement, including without limitation any Connecticut Taxes, with respect to tangible personal property purchased at any location for use in the performance of Services contemplated by this Agreement.

Contractor should consult with its tax advisor and/or its attorney, and the Connecticut Department of Revenue Services (“DRS”) and any other applicable tax authority, with regard to such tax authorities’ policies, procedures, recordkeeping and filing requirements for reimbursement of any taxes, including without limitation Connecticut Taxes, paid in the performance of Services contemplated by this Agreement, and whether or not there is a mechanism available to Contractor for the reimbursement of taxes, including without limitation Connecticut Taxes, paid on fuel purchased for use in the performance of the Services contemplated by this Agreement.

Contractor and CRRA agree that Contractor is and shall act as an independent contractor. Notwithstanding Contractor’s status as an independent contractor, but without limiting Contractor’s obligation hereunder to pay, and be solely responsible for, any Connecticut taxes levied, imposed or applicable to the Services, for the sole purpose of allowing CRRA to benefit from the aforesaid exemption, CRRA shall designate, and Contractor has agreed to act, as CRRA’s agent in purchasing services and equipment, machinery, parts, materials, supplies, inventories, fuel, and other items necessary to perform the Services hereunder for the account of CRRA, and with funds provided as reimbursement therefore by CRRA.

4. TERM OF AGREEMENT

4.1 Term

The term of this Agreement shall commence upon the Effective Date and shall terminate, unless otherwise terminated or extended in accordance with the terms and provisions hereof, on August 31, 2014.

Contractor shall retain and maintain accurate records and documents relating to the performance of Services under this Agreement for a minimum of three (3) years after final payment by CRRA for the Services hereunder and shall make them available for inspection and audit by CRRA. Contractor’s obligations under this paragraph shall survive the termination or expiration of this Agreement.

4.2 Time is of the Essence

CRRA and Contractor hereby acknowledge and agree that time is of the essence with respect to Contractor’s performance of the Services hereunder. Accordingly, upon CRRA’s issuance to Contractor of a notice to proceed with the Services (the “Notice To Proceed”), which Notice To Proceed shall be issued after the parties hereto receive all of the local, state and federal permits required for the Services hereunder, Contractor shall immediately commence performance of the Services and continue to perform the same during the term of this Agree-

ment in accordance with the schedule set forth in attached **Exhibit A** in order to complete all of the Services.

4.3 Termination

CRRA may terminate this Agreement at any time by providing Contractor with ten (10) days' prior written notice of such termination. Upon receipt of such written notice from CRRA, Contractor shall immediately cease performance of all Services, unless otherwise directed in writing by CRRA. Prior to any termination of this Agreement, Contractor shall remove all of its personnel and equipment associated with this Agreement from the Property, restore any part of the Property, any of the improvements located or to be located thereon, including but not limited to any access roads, or any of the Services that requires restoration pursuant to the terms and conditions of Section 4.4 hereof. Upon termination of this Agreement pursuant to this Section 4.3,

- (a) CRRA shall pay Contractor for all Services performed and completed by Contractor prior to the termination date, provided:
 - (1) Such Services has been performed and completed by Contractor in conformance with the Standards;
 - (2) Payment for such Services has not been previously made or is not disputed by CRRA;
 - (3) Contractor is not in default hereunder; and,
 - (4) Contractor has performed and completed all its obligations under this Section 4.3 and Section 4.4 hereof to CRRA's satisfaction, and
- (b) CRRA shall have no further liability hereunder.

Except for the payment that may be required pursuant to the preceding sentence, CRRA shall not be liable to Contractor in any other manner whatsoever in the event CRRA exercises its right to terminate this Agreement.

Contractor shall transmit to CRRA originals or copies of any and all material prepared, developed or obtained under this Agreement in Contractor's possession within thirty (30) days of receipt of the written notice of termination unless otherwise directed by CRRA.

4.4 Restoration

Unless otherwise directed in writing by CRRA, Contractor shall:

- (a) Restore any part of the Property or any of the improvements located or to be located thereon, other than those areas of the Property or such improvements improved by Contractor pursuant to this Agreement, disturbed or damaged by Contractor or any of its directors, officers, employees, agents, subcontractors or materialmen to the same condition existing immediately prior to such disturbance or damage; and

- (b) Restore or repair any completed Services so disturbed or damaged to the condition required by the Contract Documents for acceptance of such Services by CRRA.

5. INDEMNIFICATION

5.1 Contractor's Indemnity

Contractor shall at all times defend, indemnify and hold harmless CRRA and its board of directors, officers, agents and employees from and against any and all claims, damages, losses, judgments, liability, workers' compensation payments and expenses (including but not limited to attorneys' fees) arising out of injuries to the person (including death), damage to property or any other damages alleged to have been sustained by: (a) CRRA or any of its directors, officers, agents, employees or other contractors, or (b) Contractor or any of its directors, officers, agents, employees, subcontractors or materialmen, or (c) any other person, to the extent any such injuries, damage or damages are caused or alleged to have been caused in whole or in part by the acts, omissions or negligence of Contractor or any of its directors, officers, agents, employees, subcontractors or materialmen. Contractor further undertakes to reimburse CRRA for damage to property of CRRA caused by Contractor or any of its directors, officers, agents, employees, subcontractors or materialmen, or by faulty, defective or unsuitable material or equipment used by it or any of them. The existence of insurance shall in no way limit the scope of this indemnification. Contractor's obligations under this Section 5.1 shall survive the termination or expiration of this Agreement.

6. INSURANCE

6.1 Required Insurance

At all times during the term of this Agreement, Contractor shall, at its sole cost and expense, procure and maintain for the duration of the contract, insurance against claims for injuries to persons or damages to property which may arise from or in connection with the performance of the Services hereunder performed by the Contractor, its agents, employees or subcontractors.

6.1.1 Minimum Scope of Insurance

Coverage shall be at least as broad as:

- (a) Commercial General Liability written on an Occurrence policy form;
- (b) Automobile Liability insurance Combined Single Limit;
- (c) Workers' Compensation insurance as required by the State in which work is being done;
- (d) Employers' Liability insurance;

- (e) Excess/Umbrella Liability insurance; and
- (f) Professional Liability insurance.

6.1.2 Minimum Limits of Insurance

Contractor shall maintain limits no less than:

- (a) General Liability:

\$1,000,000 Each Occurrence;
\$2,000,000 General Aggregate;
\$2,000,000 Products-Completed Operations Aggregate; and
\$1,000,000 Personal and Advertising Injury.

- (b) Automobile Liability:

\$1,000,000 per accident for bodily injury and property damage;
include Owned, Hired, and Non-Owned Auto Liability.

- (c) Workers' Compensation:

Statutory Limits.

- (d) Employers' Liability:

\$1,000,000 Each Accident;
\$1,000,000 Disease-Policy Limit; and
\$1,000,000 Disease-Each Employee.

- (e) Excess/Umbrella:

\$5,000,000 Each Occurrence/Aggregate; schedule the General
Liability, Automobile Liability, and Employers Liability
and follow form with the underlying terms.

- (f) Professional Liability:

\$1,000,000 Per Claim.

6.2 **Deductibles and Self-Insured Retentions**

Any deductibles or self-insured retentions must be declared to and approved by CRRA. If any person is owed, pursuant to any policy required hereunder, any sum which is subject to a deductible, Contractor shall pay such deductible.

6.3 **Other Insurance Provisions**

All policies are to contain, or be endorsed to contain, the following provisions:

- (a) CRRA must be included as additional insured on all liability insurance including General Liability, Excess Liability and Automobile Liability. The General Liability Additional Insured endorsement must include “on-going operations” and “completed operations” coverage for the additional insured.
- (b) It shall be an affirmative obligation upon Contractor to advise CRRA’s Risk Manager by fax (860-757-7741), by e-mail (lmartin@crra.org), or by correspondence (CRRA, 100 Constitution Plaza, 6th Floor, Hartford, Connecticut 06103-1722, Attn: Risk Manager) within two days of the cancellation or substantive change of any insurance policy set out herein, and failure to do so shall be construed to be a breach of this Agreement.
- (c) Contractor’s insurance must be primary and no contributions shall be permitted from any insurance or self-insurance of CRRA.
- (d) Contractor waives, and requires their insurers to waive by endorsement, subrogation rights against CRRA for losses and damages incurred under the insurance policies required by the subcontract agreement.

6.4 Acceptability of Insurance

Insurance companies must be rated A-VII or better by A.M. Best. Insurance carriers should be lawfully authorized to do business in the jurisdiction where the work is being performed, unless otherwise approved by CRRA.

CRRA shall not, because of accepting, rejecting, approving, or receiving any certificate of insurance required hereunder, incur any liability for:

- (a) The existence, non-existence, form or legal sufficiency of the insurance described on such certificate,
- (b) The solvency of any insurer, or
- (c) The payment of losses.

6.5 Verification of Coverage

No work will be performed by Contractor or any subcontractors until a certificate of insurance is submitted to CRRA complying with all these insurance requirements.

6.6 Subcontractors

Contractor shall include all subcontractors as insureds under its policies or shall furnish separate certificates and endorsements for each subcontractor. All coverages for subcontractors shall be subject to all the requirements stated herein.

7. MISCELLANEOUS

7.1 Non-Discrimination

Contractor agrees to the following:

- (a) Contractor agrees and warrants that, in the performance of the Services for CRRRA, Contractor will not discriminate or permit discrimination against any person or group of persons on the grounds of race, color, religious creed, age, marital status, national origin, ancestry, sex, sexual orientation, mental retardation, mental disability or physical disability, including, but not limited to, blindness, unless it is shown by Contractor that such disability prevents performance of the Services involved, in any manner prohibited by the laws of the United States or of the State of Connecticut; and the Contractor further agrees to take affirmative action to insure that applicants with job-related qualifications are employed and that employees are treated when employed without regard to their race, color, religious creed, age, marital status, national origin, ancestry, sex, sexual orientation, mental retardation, mental disability or physical disability, including, but not limited to, blindness, unless it is shown by Contractor that such disability prevents performance of the Services involved;
- (b) Contractor agrees, in all solicitations or advertisements for employees placed by or on behalf of Contractor, to state that it is an "affirmative action-equal opportunity employer" in accordance with regulations adopted by the Connecticut Commission on Human Rights and Opportunities (The "Commission");
- (c) Contractor agrees to provide each labor union or representative of workers with which Contractor has a collective bargaining agreement or other contract or understanding and each vendor with which Contractor has a contract or understanding, a notice to be provided by the Commission, advising the labor union, workers' representative and vendor of Contractor's commitments under Sections 4a-60 and 4a-60a of the Connecticut General Statutes and to post copies of the notice in conspicuous places available to employees and applicants for employment;
- (d) Contractor agrees to comply with each applicable provision of Sections 4a-60, 4a-60a, 46a-68e, and 46a-68f, inclusive, of the Connecticut General Statutes and with each regulation or relevant order issued by the Commission pursuant to Sections 46a-56, 46a-68e, and 46a-68f of the Connecticut General Statutes; and
- (e) Contractor agrees to provide the Commission with such information requested by the Commission, and permit access to pertinent books, records and accounts concerning the employment practices and procedures of Contractor as related to the applicable provisions of Sections 4a-60, 4a-60a and 46a-56 of the Connecticut General Statutes.

- (f) If this Agreement is a public works contract, Contractor agrees and warrants that it will make good faith efforts to employ minority business enterprises as sub-contractors and suppliers of materials in such public works project.

7.2 Entire Agreement

This Agreement constitutes the entire agreement and understanding between the parties hereto and concerning the subject matter hereof, and supersedes any previous agreements, written or oral, between the parties hereto and concerning the subject matter hereof.

7.3 Governing Law

This Agreement shall be governed by, and construed, interpreted and enforced in accordance with the laws of the State of Connecticut as such laws are applied to contracts between Connecticut residents entered into and to be performed entirely in Connecticut.

7.4 Assignment

This Agreement may not be assigned in whole or in part by either party without the prior written consent of the other party or such assignment shall be void.

7.5 No Waiver

Failure to enforce any provision of this Agreement or to require at any time performance of any provision hereof shall not be construed to be a waiver of such provision, or to affect the validity of this Agreement or the right of any party to enforce each and every provision in accordance with the terms hereof. No waiver of any provision of this Agreement shall affect the right of CRRA or Contractor thereafter to enforce such provision or to exercise any right or remedy available to it in the event of any other default involving such provision or any other provision. Making payment or performing pursuant to this Agreement during the existence of a dispute shall not be deemed to be and shall not constitute a waiver of any claims or defenses of the party so paying or performing.

7.6 Modification

This Agreement may not be amended, modified or supplemented except by a writing signed by the parties hereto that specifically refers to this Agreement. Any oral representations or letters by the parties or accommodations shall not create a pattern or practice or course of dealing contrary to the written terms of this Agreement unless this Agreement is formally amended, modified or supplemented.

7.7 Notices

All notices, requests, demands and other communications hereunder shall be in writing and shall be deemed to have been duly given if mailed via certified first class mail return receipt requested postage prepaid or overnight express mail service to the pertinent address below.

(a) If to CRRA:

Connecticut Resources Recovery Authority
100 Constitution Plaza, 6th Floor
Hartford, Connecticut 06103
Attention: Air Compliance Manager

With a copy to:

Connecticut Resources Recovery Authority
100 Constitution Plaza, 6th Floor
Hartford, Connecticut 06103
Attention: President

(b) If to Contractor:

Attention: _____

7.8 Benefit and Burden

This Agreement shall inure to the benefit of and be binding upon the heirs, personal representatives, successors and assigns of the parties hereto.

7.9 Severability

CRRA and Contractor hereby understand and agree that if any part, term or provision of this Agreement is held by any court to be invalid, illegal or in conflict with any applicable law, the validity of the remaining portions of this Agreement shall not be affected, and the rights and obligations of the parties shall be construed and enforced as if this Agreement did not contain the particular part, term or provision held to be invalid, illegal or in conflict with any applicable law.

7.10 Counterparts

This Agreement may be executed in any number of counterparts by the parties hereto. Each such counterpart so executed shall be deemed to be an original and all such executed counterparts shall constitute but one and the same instrument.

7.11 Whistleblower Protection

If any officer, employee or appointing authority of the Contractor takes or threatens to take any personnel action against any employee of the Contractor in retaliation for such employee's disclosure of information to the Auditors of Public Accounts or the Attorney General under the provisions of *Connecticut General Statutes* Section 4-61dd, the Contractor shall be

liable for a civil penalty of not more than five thousand dollars for each offense, up to a maximum of twenty per cent of the value of the contract. Each violation shall be a separate and distinct offense and in the case of a continuing violation each calendar day's continuance of the violation shall be deemed to be a separate and direct offense. The Contractor shall post a notice in a conspicuous place which is readily available for viewing by employees of the provisions of *Connecticut General Statutes* Section 4-61dd relating to large state Contractors.

7.12 Campaign Contribution And Solicitation Prohibitions

For all State contracts as defined in P.A. 07-1 having a value in a calendar year of \$50,000 or more or a combination or series of such agreements or contracts having a value of \$100,000 or more, the authorized signatory to this Agreement expressly acknowledges receipt of the State Elections Enforcement Commission's notice advising state contractors of state campaign contribution and solicitation prohibitions, and will inform its principals of the contents of the notice. See Exhibit E [SEEC Form 11].

7.13 Affidavit Concerning Nondiscrimination

At the time the Contractor submitted its bid to CRRA, it simultaneously executed a document entitled Affidavit Concerning Nondiscrimination and said document is attached hereto and made a part of this Agreement as Exhibit F.

7.14 Affidavit Concerning Consulting Fees

At the time of Contractor's execution of this Agreement, Contractor simultaneously executed a document entitled Affidavit Concerning Consulting Fees and said document is attached hereto and made a part of this Agreement as Exhibit G.

7.15 Contractor's Certification Concerning Gifts

At the time of Contractor's execution of this Agreement, Contractor simultaneously executed a document entitled Contractor's Certification Concerning Gifts and said document is attached hereto and made a part of this Agreement as Exhibit H.

7.16 President's Certification Concerning Gifts

At the time of the President of CRRA's execution of this Agreement, the President of CRRA simultaneously executed a document entitled President's Certification Concerning Gifts and said document is attached hereto and made a part of this Agreement as Exhibit I.

[REMAINDER OF PAGE INTENTIONALLY LEFT BLANK]

[SIGNATURE PAGE FOLLOWS]

IN W-ITNESS WHEREOF, the parties hereto have set their hands and seals as of the day and year first written above.

CONNECTICUT RESOURCES RECOVERY AUTHORITY

By: _____
Thomas D. Kirk
Its President
Duly Authorized

[CONTRACTOR]

By: _____
_____ [Print/Type Name]
Its _____ [Title]
Duly Authorized

**AGREEMENT
FOR
AIR EMISSIONS TESTING
AT THE
MID-CONNECTICUT POWER BLOCK FACILITY**

**EXHIBIT A
SCOPE OF SERVICES**

SCOPE OF SERVICES

1. OVERVIEW OF THE POWER BLOCK FACILITY

The Connecticut Resources Recovery Authority's ("CRRRA") Mid-Connecticut Resources Recovery Facility processes municipal solid waste and combusts it to produce steam and electricity. The Mid-Connecticut Resource Recovery Facility consists of three separate facilities:

- (a) The Waste Processing Facility ("WPF") where municipal solid waste is converted into Refuse-Derived Fuel;
- (b) The Power Block Facility (the "Facility") where Refuse-Derived Fuel from the WPF is combusted to produce steam; and
- (c) The Electricity Generation Facility where the steam from the Facility is converted into electricity.

CRRRA contracts with private entities to operate each of the facilities.

The Power Block Facility uses three combustors, each having its own flue gas treatment equipment. Each of the three combustors is rated to consume up to 28.15 tons per hour of RDF and to produce up to 231,000 pounds per hour of steam. The flue gas treatment equipment includes ductwork, acid gas treatment units and baghouses. Emissions testing takes place at the inlet to the acid gas treatment equipment and at the outlet of the baghouses on each of the three combustor units.

2. OVERVIEW OF THE SERVICES

Under this Scope Of Services, the Contractor is responsible for performing the annual air emissions performance test at the Facility in 2012, 2013 and 2014. The test must be performed in accordance with *Regulations of Connecticut State Agencies* ("RCSA") Section 22a-174-38(i). The Contractor must be familiar with RCSA 22a-174-38 and all of its provisions, especially with regard to emissions limits. Further, the Contractor must understand all of the regulation's provisions with respect to performance testing (RCSA 22a-174-38(i)), calculations, recordkeeping and reporting (RCSA 22a-174-38(l)). The Contractor must have the knowledge and experience to perform testing pursuant to the methods referenced in RCSA 22a-174-38(i) (except as otherwise specified herein), generate meaningful emissions data and defend that data with accepted quality assurance and quality control methods.

The Contractor and any Subcontractors used by the Contractor, including, but not limited to, analytical laboratories, must be in all ways trained, qualified, and certified, as required by the applicable regulations, to perform all activities associated with this testing and analysis. This includes any and all required safety training and obtaining the required

training and certifications for the performance of all of the methods of sampling specified in RCSA 22a-174-38(i).

The Contractor is responsible for the preparation of certain communications with the Connecticut Department of Environmental Protection ("CTDEP") as specified in RCSA 22a-174-38(l). This includes, but is not limited to, providing the performance test plan, which includes proper notice of the intent to test the Facility and details of sampling protocols and locations (RCSA 22a-174-38(l)(4)), and the performance test report. These reports shall be provided to CRRA for review and timely submittal to CTDEP.

The Contractor will be provided with electrical hookup, Continuous Emissions Monitoring System ("CEMS") data, and access to the Facility and a Facility liaison person. The Contractor must provide any other needed tools, devices, equipment, supplementary access, information, transportation, communication, labor, and supervision to perform the field services. The Contractor is required to communicate with the Facility liaison person prior to initiating any test runs to determine the status of Facility operations so that samples will reflect normal Facility operation conditions.

The Contractor is responsible for coordination of any and all parties participating in the project on its behalf.

3. PERIOD OF PERFORMANCE

The Scope of Services described herein is expected to be completed not later than July 31, 2014, weather permitting, with an absolute completion date of August 31, 2014. Site work should take no more than two weeks each year and should be accomplished with one mobilization and one demobilization per year.

It is anticipated that, for the first year, the successful bidder will begin work on the Intent To Test and Test Protocol documents on or about December 1, 2011, per the direction of CRRA. Actual testing will occur in April or May 2012, with the Final Test Report due to CTDEP within sixty days of the completion of testing. Similarly, for the second year, work will begin on the Intent To Test and Test Protocol documents on or about December 1, 2012, per the direction of CRRA. Actual testing will occur in April or May 2013, with the Final Test Report due to CTDEP within sixty days of the completion of testing. Finally, for the third year, work will begin on the Intent To Test and Test Protocol documents on or about December 1, 2013, per the direction of CRRA. Actual testing will occur in April or May 2014, with the Final Test Report due to CTDEP within sixty days of the completion of testing.

4. COMMENCEMENT OF WORK

On the Effective Date of the Agreement, or as directed by CRRA, the Contractor will commence work on the Intent to Test transmittal to CTDEP, as described in RCSA 22a-174-38(l)(4). CTDEP's review and approval of the Intent to Test may take up to ninety (90) days. Source testing will take place in April or May of 2012, 2013 and 2014, respectively.

5. WORK TO BE PERFORMED

The work to be performed under the Scope Of Services is summarized by the following Tasks.

5.1 Task 1: Field Services

SAFETY

Safety is the most important consideration in the execution of the field services work. There are hazards involved in the project, particularly in the Field Services portion of the project. Prior to commencement of any work at the Facility, on every day that such work will take place, a safety meeting will be held and documented by the Contractor. The safety meeting will be attended by representatives of the Contractor, the Facility operator's liaison personnel, CTDEP (if present) and CRRA. This meeting will include a review of any safety concerns of any of the parties and a discussion of the work to be done that day. Copies of the documentation of each day's safety meeting will be provided to representatives of each party on the next working day.

During the course of all site work, the Contractor's personnel will be subject to observation by the Facility operator's personnel, CRRA personnel and CTDEP personnel (if present). If any of these personnel observe any unsafe acts or conditions or potentially unsafe acts or conditions, work will cease and the Contractor will take the appropriate corrective action. Any unsafe or potentially unsafe acts or conditions caused by the Contractor or its personnel will be corrected at the expense of the Contractor.

Contractor shall perform all field activities needed to physically take the required samples, or otherwise measure or determine pertinent conditions as described in RCSA 22a-174-38(i) for particulate matter, opacity, cadmium, lead, mercury, sulfur dioxide, nitrogen oxides, carbon monoxide, hydrogen chloride, dioxin/furans, and fugitive ash. Mercury and hydrogen chloride must be sampled at the three inlet locations. Particulate matter, cadmium, lead, mercury, and hydrogen chloride must be sampled at the three outlet locations. Dioxin/furan must be sampled at only one outlet location in 2012. Bidders should assume that dioxin/furan must be sampled at three outlet locations in 2013 and 2014 and include the cost for this in their bid price. Inlet and outlet testing for mercury and hydrogen chloride must be conducted simultaneously. Sulfur dioxide, nitrogen oxides and opacity are recorded on the Facility's Continuous Emissions Monitoring System (CEMS). Isokinetic sampling for hydrogen chloride emission concentration (inlet and outlet) shall be conducted in accordance with Method 26A as set out in

Appendix A to Part 60 of Title 40 of the Code of Federal Regulations (40 CFR 60, Appendix A, Method 26A). CRRA requires on-site titration measurement of HCl at the inlet and outlet locations for each of the three runs on each of the three units.

It is the Contractor's responsibility to obtain the appropriate reports from the CEMS to complete the submittals required to demonstrate compliance with the parameters listed above pursuant to RCSA 22a-174-38. The Contractor shall prepare a statement indicating that the carbon dioxide/oxygen relationship does not need to be established due to the presence of an outlet oxygen sensor.

Because of the requirement to test for mercury and hydrogen chloride at the inlet and outlet simultaneously, Contractor must provide a means of communication between crews working at the inlet and outlet locations. In addition, Contractor must provide a means of communication with CTDEP staff and with the Facility control room.

The Contractor is responsible for performance testing, including proper handling of samples through laboratory analysis and proper ultimate disposal. The Contractor shall use properly calibrated sampling equipment, which is acceptable to CTDEP, for such testing and technicians trained in the use of the equipment.

The inlet duct sampling locations have very restricted access, very limited working space and are at an elevated level above the ground. The Contractor is responsible for all special accommodations that must be made for safely obtaining samples from these locations. Such accommodations may include, but are not limited to, rigging, tools and additional labor. Also note that the Contractor is responsible for meeting with the Facility's liaison personnel for approval of the Contractor's written plan for such rigging and tools as are needed. The Contractor bears the responsibility for design, approval (by Facility operator), construction, inspection and maintenance of any and all modifications to existing platforms and work areas. Furthermore, the Contractor is required to return the job site to its previous condition following completion of the testing and submission of the test report to CTDEP.

In addition to the emissions testing required by RCSA 22a-174-38, the facility holds a Title V Air Operating Permit that requires annual testing for ammonia emissions for all three units in accordance with EPA Reference Method CTM-027. Bidder's proposals shall include pricing for this testing in each of the three years of the contract term.

Important! - Note that bids shall not include a schedule that calls for sampling to occur at more than two sites simultaneously. That is, bids should reflect that sampling will only be done at the inlet and outlet of one unit or at the outlets of two units simultaneously. See Attachment 1 for details of sampling locations.

5.2 Task 2: Laboratory Analysis

Contractor shall perform, or have a qualified subcontractor perform, laboratory analyses pursuant to the methods required for each parameter in RCSA 22a-174-38. The laboratory must be duly accredited, recognized and certified by the CTDEP for performance of such analyses. Proof of such certification shall be included in the test report. The laboratory shall generate emissions data in accordance with the specifications of RCSA 22a-174-38 and defend that data with accepted quality assurance and quality control methods.

Laboratory analysis shall be performed on an expedited basis so as to allow the greatest opportunity for CRRA review of the draft test report prior to submission to CTDEP. Contractor must deliver to CRRA a draft test report which must include all laboratory results within forty five (45) days after the completion of testing.

The CTDEP requires the Contractor to analyze a number of “audit samples” as a quality control/quality assurance measure. These samples are: one dioxin/furan, two hydrogen chloride, one mercury and one metals. Contractor’s Not To Exceed Bid Price for Laboratory Analysis shall cover analysis of five such samples each year, 2012, 2013 and 2014. Contractor may contact CTDEP Source Emissions Monitoring staff for information on “audit samples.”

5.3 Task 3: Regulatory Document Preparation and Submittal

The Contractor will prepare and submit to CRRA for review and comment a draft Test Protocol and a draft Intent to Test (“ITT”) Transmittal as described in RCSA 22a-174-38(l)(4). The draft Test Protocol and ITT Transmittal will be submitted to CRRA at least one week prior to submission to CTDEP. Following CRRA review, Contractor will submit the Test Protocol and ITT Transmittal to CTDEP. In consultation with CRRA, Contractor will respond to any inquiries from CTDEP about the Test Protocol and ITT Transmittal.

Contractor shall prepare and submit a complete draft report to CRRA for review and comment at least three weeks prior to the submission of the final report to CTDEP. The draft report must include the results of the laboratory analyses as specified in RCSA 22a-174-38(l). All calculation methods, dimensional units, format and schedule for completion will be consistent with RCSA 22a-174-38(l). Reports will be of a type and quality acceptable to CTDEP for compliance demonstrations. Reports shall include Facility CEMS data indicating that sampling was conducted during a period of normal facility operation. Reports shall include a conclusion of compliance or non-compliance with the RCSA 22a-174-38 limits for each criterion for each boiler train at the Facility. Results for all test parameters, along with the RCSA 22a-174-38 emission limits, percent reductions or other compliance determination standard shall be clearly presented in three tables, one for each boiler. Additionally, an Executive Summary section shall be prepared that provides a brief description of the compliance status of the Facility and one table that compares the average measured parameter values to the applicable limit or standard.

Contractor shall prepare a complete, detailed record of all expenses associated with the work performed under the Scope Of Services in a manner consistent with the guidelines established by CTDEP so that such costs can be reimbursed to CRRA. Documentation to be submitted may include, but is not limited to, travel and living expense receipts, laboratory invoices and such other documentation as CTDEP may require. Contractor shall also supply CRRA and CTDEP with Equal Opportunity/Affirmative Action information and documentation as required by CTDEP for reimbursement of such costs.

ATTACHMENT 1
To
EXHIBIT A
To
POWER BLOCK FACILITY
AIR EMISSIONS TESTING AGREEMENT

SAMPLING LOCATIONS

ATTACHMENT 1

SAMPLING LOCATIONS

Sampling ports and sample point locations were determined in accordance with EPA Method 1. The following sections present description of the sampling locations. Schematics (EPA Method 1 sheets) are presented at the end of this section.

1. Inlet Sampling Locations

Inlet sampling for HC1 and mercury was conducted prior to the SDA units associated with each boiler in the 84" by 66" vertical duct. The inlet sampling locations for all three units are identical. Five sampling ports were installed in the 84" face. The ports were located 116" upstream and 308 inches downstream of flow disturbances. A total of 25 points (5 points per port) were sampled during each isokinetic sampling run. Due to the configuration of support structures around the SDA inlets only four of the five test ports were accessible. Sampling in port number 4 was conducted twice.

2. Outlet Sampling Locations

Outlet sampling for PM/HC1, metals, and dioxin/furans was conducted after the baghouses associated with each boiler. The Unit 11 and Unit 12 sampling locations are identical. For each of these locations five ports were installed in the 72" face of the 70" by 72" vertical duct. The ports were located 132 inches upstream and 192 inches downstream of flow disturbances. A total of 25 points (5 points per port) were sampled during each isokinetic sampling run.

The Unit 13 sampling location consists of five ports that were installed in the 60" face of a 60" by 108" duct. The ports were located 154" upstream and 231" downstream of flow disturbances. A total of 25 points (5 points per port) were sampled during each isokinetic sampling run.

EPA Method 1 Data Sheet

Firm CRRA Mid-Conn
 Location Units 11 and 12 Outlets
 Diameters Upstream 1.8
 Diameters Downstream 2.7
 Nipple Size (in.) 9

Total Traverse Points Required 25
 Number of Ports 5
 Points Per Port 5
 Traverse (Horizontal or Vertical) Horizontal

Minimum Number of Traverse Points For Particulate and Non-Particulate Traverses

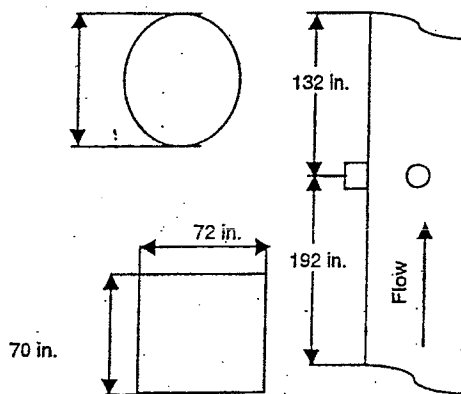
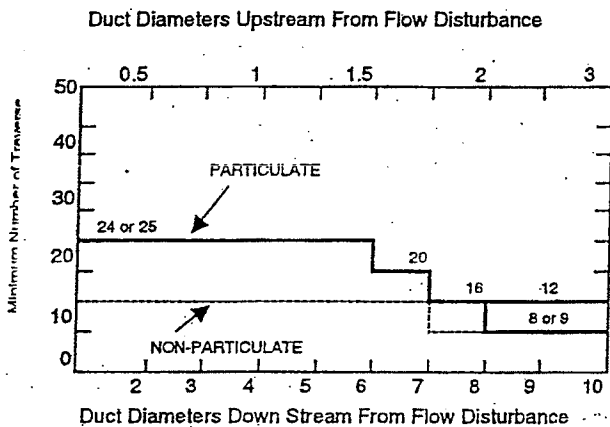

Cross-Sectional Layout For Rectangular Stacks	
Total	
Total Traverse Points	Matrix
9	3x3
12	4x3
16	4x4
20	5x4
25	5x5

Point Number	(Percent of Stack Diameter from Inside Wall to Traverse Point)				
	(No. of Traverse Points on a Dia.)				
On a Diameter	4	6	8	10	12
1	6.7	4.4	3.2	2.6	2.1
2	25.0	14.6	10.5	8.2	6.7
3	75.0	29.6	19.4	14.6	11.8
4	93.3	70.4	32.3	22.6	17.7
5	c	85.4	67.7	34.2	25.0
6		95.6	80.6	65.8	35.6
7			89.5	77.4	64.4
8			96.8	85.4	75.0
9				91.8	82.3
10				97.4	88.2
11					93.3
12					97.9

Traverse Point Location			
Point Number	Distance From Wall	Nipple Size	Total Distance
1	7.0	9.0	16.0
2	21.0	9.0	30.0
3	35.0	9.0	44.0
4	49.0	9.0	58.0
5	63.0	9.0	72.0
6			
7			
8			
9			
10			
11			
12			

EPA Method 1 Data Sheet

Firm CRRA Mid-Conn
 Location Units 11, 12, and 13 Inlet
 Diameters Upstream 1.5
 Diameters Downstream 4.1
 Nipple Size (in.) 14

Total Traverse Points Required 25
 Number of Ports 5
 Points Per Port 5
 Traverse (Horizontal or Vertical) Horizontal

Minimum Number of Traverse Points For Particulate and Non-Particulate Traverses

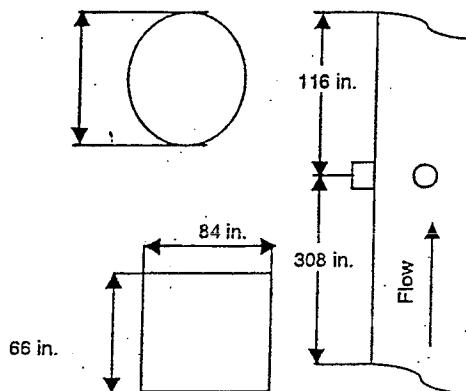
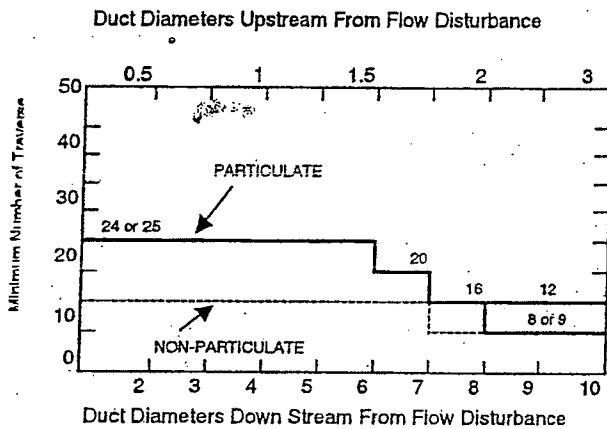

Cross-Sectional Layout For Rectangular Stacks Total	
Total Traverse Points	Matrix
9	3x3
12	4x3
16	4x4
20	5x4
25	5x5

Point Number On a Diameter	(Percent of Stack Diameter from - Inside Wall to Traverse Point)				
	(No. of Traverse Points on a Dia.)				
	4	6	8	10	12
1	6.7	4.4	3.2	2.6	2.1
2	25.0	14.6	10.5	8.2	6.7
3	75.0	29.6	19.4	14.6	11.8
4	93.3	70.4	32.3	22.6	17.7
5	c	85.4	67.7	34.2	25.0
6		95.6	80.6	65.8	35.6
7			89.5	77.4	64.4
8			96.8	85.4	75.0
9				91.8	82.3
10				97.4	88.2
11					93.3
12					87.9

Traverse Point Location			
Point Number	Distance From Wall	Nipple Size	Total Distance
1	6.6	14.0	20.6
2	19.8	14.0	33.8
3	33.0	14.0	47.0
4	46.2	14.0	60.2
5	59.4	14.0	73.4
6			
7			
8			
9			
10			
11			
12			

EPA Method 1 Data Sheet

Firm CRRA Mid-Conn
 Location Unit 13 Outlet
 Diameters Upstream <2.0
 Diameters Downstream 3.0
 Nipple Size (in.) 14

Total Traverse Points Required 25
 Number of Ports 5
 Points Per Port 5
 Traverse (Horizontal or Vertical) Horizontal

Minimum Number of Traverse Points For Particulate and Non-Particulate Traverses

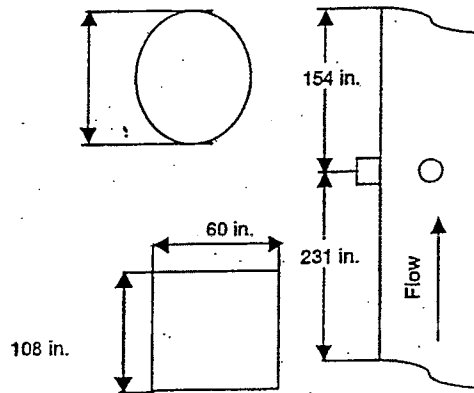
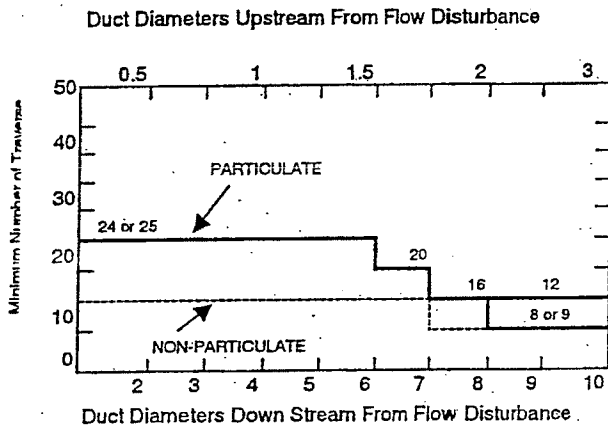

Cross-Sectional Layout For Rectangular Stacks	
Total	
Total Traverse Points	Matrix
9	3x3
12	4x3
16	4x4
20	5x4
25	5x5

Point Number	(Percent of Stack Diameter from Inside Wall to Traverse Point)				
	(No. of Traverse Points on a Dia.)				
On a Diameter	4	6	8	10	12
1	6.7	4.4	3.2	2.6	2.1
2	25.0	14.6	10.5	8.2	6.7
3	75.0	29.6	19.4	14.6	11.8
4	93.9	70.4	32.3	22.6	17.7
5	95.6	85.4	67.7	34.2	25.0
6		95.6	80.6	65.8	35.6
7			89.5	77.4	64.4
8			96.8	85.4	75.0
9				91.8	82.3
10				97.4	88.2
11					93.3
12					97.9

Traverse Point Location			
Point Number	Distance From Wall	Nipple Size	Total Distance
1	10.8	14.0	24.8
2	32.4	14.0	46.4
3	54.0	14.0	68.0
4	75.6	14.0	89.6
5	97.2	14.0	111.2
6			
7			
8			
9			
10			
11			
12			

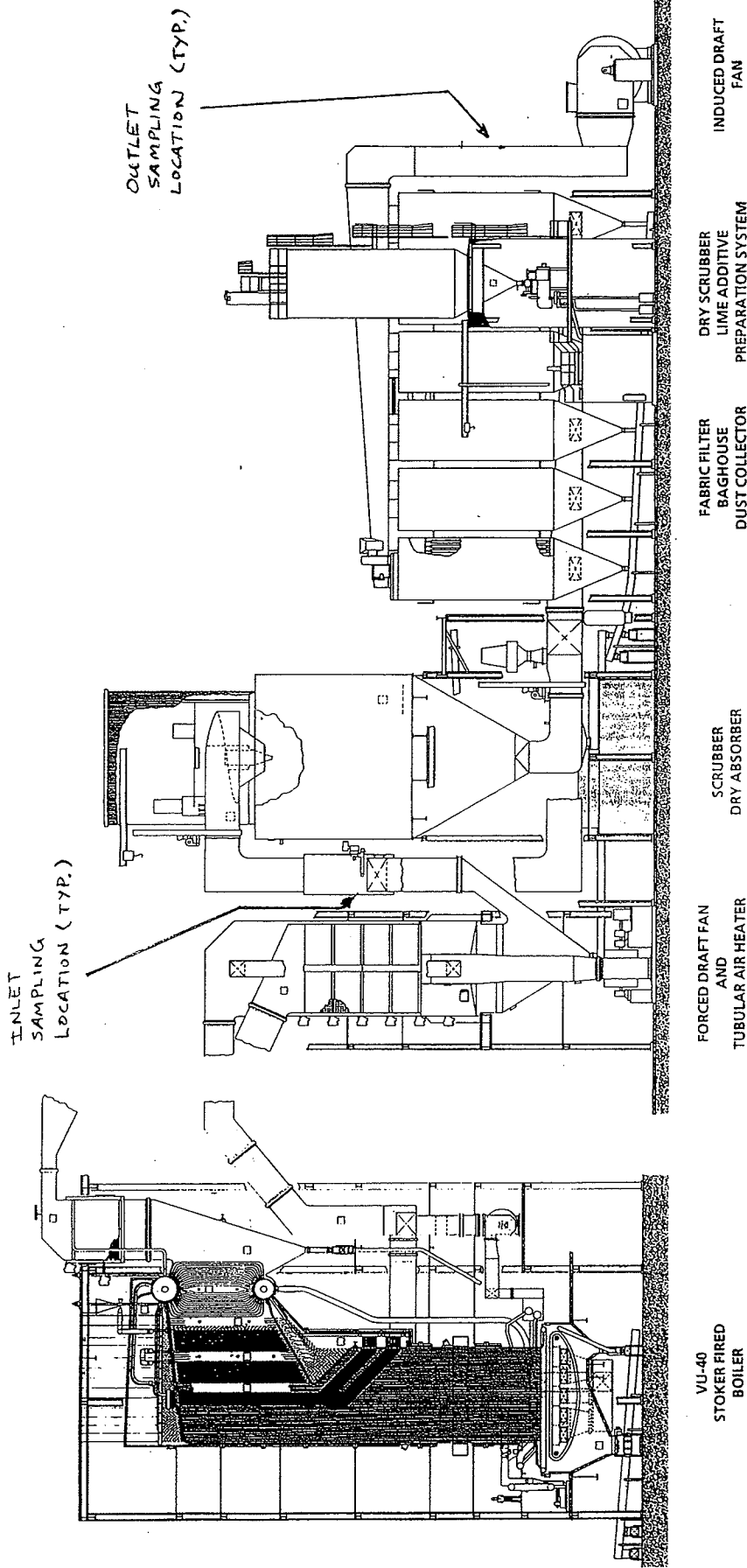

**AGREEMENT
FOR
AIR EMISSIONS TESTING
AT THE
MID-CONNECTICUT POWER BLOCK FACILITY**

**EXHIBIT B
COMPENSATION SCHEDULE**

COMPENSATION SCHEDULE

[The Contractor's "Bid Price and Payment Rate Schedule Form" that was submitted to CRRA by the Contractor with the Contractor's Bid, as such Form may be modified based on negotiations between CRRA and Contractor over prices, will be added by CRRA.]

**AGREEMENT FOR
AIR EMISSIONS TESTING
AT THE
MID-CONNECTICUT POWER BLOCK FACILITY**

EXHIBIT C

**CRRA'S TRAVEL AND EXPENSE
REPORTING POLICY AND PROCEDURE**

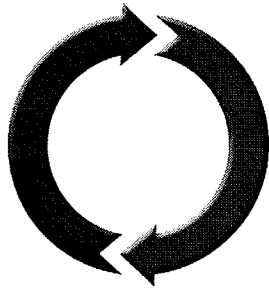

CONNECTICUT
RESOURCES
RECOVERY
AUTHORITY

TRAVEL POLICY AND EXPENSE REPORTING

**BOARD OF DIRECTORS POLICY AND PROCEDURE
NUMBER 032**

**APPROVED BY CRRA BOARD OF DIRECTORS
SEPTEMBER 29, 2005**

TABLE OF CONTENTS

1.	GENERAL STATEMENT.....	1
2.	APPROVALS.....	1
3.	TRANSPORTATION.....	1
	3.1 Rental Automobile.....	2
	3.2 Business Use Of Employee's Car.....	2
	3.3 Air Travel.....	3
	3.4 Taxis.....	3
	3.5 CRRA Owned Automobiles.....	4
4.	MEALS.....	4
5.	LODGING.....	4
6.	INCIDENTALS.....	4
7.	PERSONAL EXPENSES.....	4
8.	OTHER BUSINESS EXPENSES.....	4
9.	EXPENSE REPORTING.....	5
10.	RECEIPTS.....	5
11.	EXCEPTIONS.....	5

CONNECTICUT RESOURCES RECOVERY AUTHORITY TRAVEL POLICY AND EXPENSE REPORTING

1. GENERAL STATEMENT

This Travel Policy and Expense Reporting guide presents the policies that all CRRA employees (hereafter “employee(s)”) must adhere to in the planning and conducting of their business travel and their reimbursement requests. CRRA requires that all travel expenditures and their accountings meet the Internal Revenue Service requirements of “ordinary, necessary and reasonable” and should be conservative and consistent with the nature of the business assignment. These policies safeguard CRRA and protect the employee from being assessed additional taxable income. All employees are expected to fully comply with the policies and instructions in this guide. Reimbursements for actual and necessary expenses made to Directors of CRRA shall be made consistent with the provisions of this Travel Policy And Expense Reporting guide; however, as stated in the Connecticut General Statutes, Directors shall not be required to obtain pre-approval from the President for any expenses.

2. APPROVALS

Prior written approval by the President or the employee’s Division Head at least one (1) week in advance is required for all overnight trips out of state, except in an emergency. It is the obligation of the employee to obtain this prior approval and no reimbursement will be made without this approval.

Prior written approval by the President or the employee’s Division Head at least one (1) week in advance is required for all employee trips that are for educational seminars, professional conferences, vendor-initiated field trips, and industry organization events.

To obtain written approval, the employee must complete the overnight travel form, and, if a cash advance is requested, complete a cash advance form that estimates the out-of-pocket expenses, and submit the completed form(s) to the appropriate Division Head or President in as far in advance as possible of departure date.

3. TRANSPORTATION

Transportation expenses should be kept to a minimum. The most direct and practical route should be selected.

3.1 Rental Automobile

Rental car expenses will be paid by CRRA and whenever possible should be billed directly to CRRA to take advantage of CRRA's tax-exempt status and any other discounts available to CRRA.

3.1.1 Insurance

3.1.1.1 Business Use Of A Rental Automobile

Employees on business do not need to purchase additional insurance coverage (collision damage waiver or excess liability) from the rental company. The Corporate Insurance Program covers these risks. Please note that all vehicles must be rented in CRRA's name to have CRRA's policy cover the employee.

3.1.1.2 Personal Use Of A Rental Automobile

Employees are prohibited from using a CRRA rental automobile for personal use. Personal use that is incidental to CRRA business use will be covered by the CRRA insurance policy as long as the vehicle was rented in CRRA's name. Incidental usage is defined as usage of the vehicle that is directly related to business usage (e.g. mileage to get meals on a business trip).

3.2 Business Use Of Employee's Car

3.2.1 Reimbursement Rate

The reimbursement rate for an employee's use of their personal automobile for CRRA business is the IRS approved rate, as adjusted from time to time by the IRS, for employee use of their personal car on business. The above mileage reimbursement allowance for business use of an employee's vehicle is calculated in a manner that takes into account all auto-related expenses, including the cost of carrying insurance (without a deductible). Therefore, CRRA will not reimburse an employee for vehicle damage or personal liability that occurs while a personal automobile is being used on CRRA business if the employee drives their personal vehicle 2,500 miles per year or more. This includes any deductible that may apply. However, if an employee's vehicle is driven on company business 2,500 miles or less annually, and is involved in a motor vehicle accident, CRRA will reimburse the employee through the normal expense reimbursement process for their physical damage deductible up to a maximum of \$500.00 per accident. Evidence of the payment of the deductible by the employee must be provided to CRRA in order to receive reimbursement. (Traveling on business does not include any travel involved in commuting to or from work, lunch time errands or anything other than authorized business use). Before an employee seeks the foregoing reimbursement for the use of his personal automobile, the

employee shall provide CRRA with written evidence of his personal automobile insurance with limits as required by the Connecticut General Statutes. The foregoing written proof shall be kept on file in the CRRA Finance Division.

3.2.2 Mileage Calculation

In all travel away from the CRRA office, the employee will be reimbursed using the shortest distance between points. For travel from Hartford to a CRRA facility, the President shall cause the shortest distance to be determined and the President shall cause such determination to be made available to employees. Unless approved by an employee's Division Head, employees shall use the distances determined by the President in all requests for reimbursement for travel from Hartford to a CRRA facility. An employee may request and the employee's Division Head may approve distances other than those determined by the President in extraordinary circumstances when, for reasons beyond the control of the employee, the route of the shortest distance was not reasonably available for use.

In calculating mileage, the normal commute mileage to and from the employee's home to the employee's assigned place of work must be deducted from the total trip mileage. For example, if the total trip mileage equals 100 miles, and normal commute mileage equals 20 miles, CRRA will reimburse the employee for 80 miles. This is in accordance with Internal Revenue Service and State of Connecticut policy.

3.2.3 Tolls/Parking

No receipts are necessary for tolls or parking unless they exceed five (\$5.00) dollars.

3.3 Air Travel

All air travel requires prior approval from the CRRA President. For approved travel, CRRA will reimburse employees only for coach accommodations. Employees are encouraged to inquire about discount packages and to take advantage of the least costly route whenever possible. When an employee plans a trip, the reservations should be made as far in advance as practical to obtain the lowest rate. All approved air travel for the previous month shall be reported to the CRRA Board of Directors at its next Board Meeting.

3.4 Taxis

Taxi service may be used when no other form of public transportation is available or when the cost of a taxi is close to the cost of public transportation. Employees are encouraged to use courtesy cars, airport limousines, or buses whenever possible. Since some taxi services do not provide receipts, you should have the back of your business card signed, dated, and the amount of the fare indicated by the driver.

3.5 CRRA Owned Automobiles

Please refer to the CRRA Vehicle Usage Policy adopted by the CRRA Board of Directors at its November 21, 2003, Board of Directors Meeting.

4. MEALS

Permissible expenditures for meals and tips depend on location and circumstances. Only reasonable and customary charges will be allowed and reimbursed by CRRA. An exception may be granted by the President in unusual circumstances. In-state breakfast, lunch, and dinner will not be reimbursed unless they involve a business meeting.

5. LODGING

Lodging accommodations in reasonable and economically priced single occupancy rooms, including customary tips, are reimbursable if the employee has to stay away from home overnight because of unfinished business or an early morning business meeting.

Employees should request government rates at the time of making reservations.

6. INCIDENTALS

The incidentals allowance encompasses such things as gratuities and one telephone call a day of reasonable duration to the employee's home. It is anticipated that the cost of such calls generally will appear on the employee's hotel bill.

7. PERSONAL EXPENSES

Some travel expenses are considered personal and CRRA will not reimburse them. The following, while not all inclusive, lists examples of such personal expenses that are not reimbursable expenses: amusements, athletic events, barbers, books for personal reading, athletic court or gym costs, damage to luggage, fines, hair stylists, magazines, newspapers, movies, and saunas.

8. OTHER BUSINESS EXPENSES

With prior approval of the President, CRRA will reimburse an employee for the incidental costs necessary to further an important CRRA business purpose. Any foregoing expense must be reported to the Board at the Board's next Board of Directors meeting. Any such expense must be documented by showing the following:

- The name(s) of the person or persons and the location and nature of the expense.
- The business relationship with CRRA.
- The specific business reason for the expense.
- The actual business conducted.

CRRA will not reimburse the cost of home entertaining.

9. EXPENSE REPORTING

All expense reporting must be submitted to CRRA using the CRRA expense reimbursement form(s) within twenty working days after the day the employee returns from his/her trip.

10. RECEIPTS

Employees shall obtain receipts for all travel expenses, exclusive of mileage reimbursement. This includes receipts for all meals, airfare, bus fare, taxi, toll or parking charges in excess of \$5.00 dollars, limousine, hotel, and registration fees. Travel expenses in excess of the stated guidelines herein will be reimbursed only if all receipts accompany expense vouchers. Expenses submitted without a receipt, except for gratuity and certain transfer charges, may not be reimbursed.

Original receipts are required for all entertainment.

11. EXCEPTIONS

Exceptions to these travel and expense guidelines will be authorized only upon the prior authorization of President when the circumstances warrant. Any such exception to these travel and expense guidelines should be documented and the President should notify the CRRA Board of Directors of such exception at the Board's next Board Meeting.

ORIGINAL

Approved by: Board of Directors
Effective Date: 05/20/04

REVISION 1

Prepared by: Jim Bolduc, Chief Financial Officer
Approved by: Board of Directors
Effective Date: 09/29/05

**AGREEMENT FOR
AIR EMISSIONS TESTING
AT THE
MID-CONNECTICUT POWER BLOCK FACILITY**

**EXHIBIT D
MONTHLY BILL FORMAT**

MONTHLY BILL FORMAT

Name of Contractor:	
Contract Number:	
Billing Period:	
Project Name:	Air Emissions Testing At The Mid-Connecticut Power Block Facility.
Purchase Order Number:	

TASK (Insert Task Number and Name; Use a separate set of tables for each task.)

Personnel	Title	Work Performed	Hours	Rate	Amount
(Insert Name of Person who worked on Task)					
(Insert Name of Person who worked on Task)					
(Insert Name of Person who worked on Task)					
Subtotal Personnel					
Ancillary Services/Equipment			Units	Rate	Amount
(Insert Name of Ancillary Services/Equipment used for Task)					
(Insert Name of Ancillary Services/Equipment used for Task)					
(Insert Name of Ancillary Services/Equipment used for Task)					
Subtotal Ancillary Services/Equipment					
Subcontractors			Invoice Amount*	Mark-up	Amount
(Insert name of subcontractor who worked on Task)					
(Insert name of subcontractor who worked on Task)					
(Insert name of subcontractor who worked on Task)					
Subtotal Subcontractors					

Subtotal for Task (Insert Task Number)	
---	--

TOTAL (Insert billing period for which bill is being submitted)	
--	--

**AGREEMENT FOR
AIR EMISSIONS TESTING
AT THE
MID-CONNECTICUT POWER BLOCK FACILITY**

EXHIBIT E

**SEEC FORM 11
NOTICE TO EXECUTIVE BRANCH STATE
CONTRACTORS AND PROSPECTIVE STATE
CONTRACTORS OF CAMPAIGN
CONTRIBUTION AND SOLICITATION BAN**

NOTICE TO EXECUTIVE BRANCH STATE CONTRACTORS AND PROSPECTIVE STATE CONTRACTORS OF CAMPAIGN CONTRIBUTION AND SOLICITATION BAN

This notice is provided under the authority of Connecticut General Statutes 9-612(g)(2), as amended by P.A. 07-1, and is for the purpose of informing state contractors and prospective state contractors of the following law (italicized words are defined on the following page):

Campaign Contribution and Solicitation Ban

No state contractor, prospective state contractor, principal of a state contractor or principal of a prospective state contractor, with regard to a state contract or state contract solicitation with or from a state agency in the executive branch or a quasi-public agency or a holder, or principal of a holder of a valid prequalification certificate, shall make a contribution to, or solicit contributions on behalf of (i) an exploratory committee or candidate committee established by a candidate for nomination or election to the office of Governor, Lieutenant Governor, Attorney General, State Comptroller, Secretary of the State or State Treasurer, (ii) a political committee authorized to make contributions or expenditures to or for the benefit of such candidates, or (iii) a party committee;

In addition, no holder or principal of a holder of a valid prequalification certificate, shall make a contribution to, or solicit contributions on behalf of (i) an exploratory committee or candidate committee established by a candidate for nomination or election to the office of State senator or State representative, (ii) a political committee authorized to make contributions or expenditures to or for the benefit of such candidates, or (iii) a party committee.

Duty to Inform

State contractors and prospective state contractors are required to inform their principals of the above prohibitions, as applicable, and the possible penalties and other consequences of any violation thereof.

Penalties for Violations

Contributions or solicitations of contributions made in violation of the above prohibitions may result in the following civil and criminal penalties:

Civil penalties--\$2000 or twice the amount of the prohibited contribution, whichever is greater, against a principal or a contractor. Any state contractor or prospective state contractor which fails to make reasonable efforts to comply with the provisions requiring notice to its principals of these prohibitions and the possible consequences of their violations may also be subject to civil penalties of \$2000 or twice the amount of the prohibited contributions made by their principals.

Criminal penalties—Any knowing and willful violation of the prohibition is a Class D felony, which may subject the violator to imprisonment of not more than 5 years, or \$5000 in fines, or both.

Contract Consequences

Contributions made or solicited in violation of the above prohibitions may result, in the case of a state contractor, in the contract being voided.

Contributions made or solicited in violation of the above prohibitions, in the case of a prospective state contractor, shall result in the contract described in the state contract solicitation not being awarded to the prospective state contractor, unless the State Elections Enforcement Commission determines that mitigating circumstances exist concerning such violation.

The State will not award any other state contract to anyone found in violation of the above prohibitions for a period of one year after the election for which such contribution is made or solicited, unless the State Elections Enforcement Commission determines that mitigating circumstances exist concerning such violation.

Additional information and the entire text of P.A 07-1 may be found on the website of the State Elections Enforcement Commission, www.ct.gov/seec. Click on the link to "State Contractor Contribution Ban."

Definitions:

"State contractor" means a person, business entity or nonprofit organization that enters into a state contract. Such person, business entity or nonprofit organization shall be deemed to be a state contractor until December thirty-first of the year in which such contract terminates. "State contractor" does not include a municipality or any other political subdivision of the state, including any entities or associations duly created by the municipality or political subdivision exclusively amongst themselves to further any purpose authorized by statute or charter, or an employee in the executive or legislative branch of state government or a quasi-public agency, whether in the classified or unclassified service and full or part-time, and only in such person's capacity as a state or quasi-public agency employee.

"Prospective state contractor" means a person, business entity or nonprofit organization that (i) submits a response to a state contract solicitation by the state, a state agency or a quasi-public agency, or a proposal in response to a request for proposals by the state, a state agency or a quasi-public agency, until the contract has been entered into, or (ii) holds a valid prequalification certificate issued by the Commissioner of Administrative Services under section 4a-100. "Prospective state contractor" does not include a municipality or any other political subdivision of the state, including any entities or associations duly created by the municipality or political subdivision exclusively amongst themselves to further any purpose authorized by statute or charter, or an employee in the executive or legislative branch of state government or a quasi-public agency, whether in the classified or unclassified service and full or part-time, and only in such person's capacity as a state or quasi-public agency employee.

"Principal of a state contractor or prospective state contractor" means (i) any individual who is a member of the board of directors of, or has an ownership interest of five per cent or more in, a state contractor or prospective state contractor, which is a business entity, except for an individual who is a member of the board of directors of a nonprofit organization, (ii) an individual who is employed by a state contractor or prospective state contractor, which is a business entity, as president, treasurer or executive vice president, (iii) an individual who is the chief executive officer of a state contractor or prospective state contractor, which is not a business entity, or if a state contractor or prospective state contractor has no such officer, then the officer who duly possesses comparable powers and duties, (iv) an officer or an employee of any state contractor or prospective state contractor who has *managerial or discretionary responsibilities with respect to a state contract*, (v) the spouse or a *dependent child* who is eighteen years of age or older of an individual described in this subparagraph, or (vi) a political committee established or controlled by an individual described in this subparagraph or the business entity or nonprofit organization that is the state contractor or prospective state contractor.

"State contract" means an agreement or contract with the state or any state agency or any quasi-public agency, let through a procurement process or otherwise, having a value of fifty thousand dollars or more, or a combination or series of such agreements or contracts having a value of one hundred thousand dollars or more in a calendar year, for (i) the rendition of services, (ii) the furnishing of any goods, material, supplies, equipment or any items of any kind, (iii) the construction, alteration or repair of any public building or public work, (iv) the acquisition, sale or lease of any land or building, (v) a licensing arrangement, or (vi) a grant, loan or loan guarantee. "State contract" does not include any agreement or contract with the state, any state agency or any quasi-public agency that is exclusively federally funded, an education loan or a loan to an individual for other than commercial purposes.

"State contract solicitation" means a request by a state agency or quasi-public agency, in whatever form issued, including, but not limited to, an invitation to bid, request for proposals, request for information or request for quotes, inviting bids, quotes or other types of submittals, through a competitive procurement process or another process authorized by law waiving competitive procurement.

"Managerial or discretionary responsibilities with respect to a state contract" means having direct, extensive and substantive responsibilities with respect to the negotiation of the state contract and not peripheral, clerical or ministerial responsibilities.

"Dependent child" means a child residing in an individual's household who may legally be claimed as a dependent on the federal income tax of such individual.

"Solicit" means (A) requesting that a contribution be made, (B) participating in any fund-raising activities for a candidate committee, exploratory committee, political committee or party committee, including, but not limited to, forwarding tickets to potential contributors, receiving contributions for transmission to any such committee or bundling contributions, (C) serving as chairperson, treasurer or deputy treasurer of any such committee, or (D) establishing a political committee for the sole purpose of soliciting or receiving contributions for any committee. Solicit does not include: (i) making a contribution that is otherwise permitted by Chapter 155 of the Connecticut General Statutes; (ii) informing any person of a position taken by a candidate for public office or a public official, (iii) notifying the person of any activities of, or contact information for, any candidate for public office; or (iv) serving as a member in any party committee or as an officer of such committee that is not otherwise prohibited in this section.

**AGREEMENT FOR
AIR EMISSIONS TESTING
AT THE
MID-CONNECTICUT POWER BLOCK FACILITY**

EXHIBIT F

**AFFIDAVIT CONCERNING
NONDISCRIMINATION**

AFFIDAVIT CONCERNING NONDISCRIMINATION

[The Contractor's "Affidavit Concerning Nondiscrimination" that was submitted by the Contractor with the Contractor's Bid will be added by CRRA.]

**AGREEMENT FOR
AIR EMISSIONS TESTING
AT THE
MID-CONNECTICUT POWER BLOCK FACILITY**

EXHIBIT G

**AFFIDAVIT CONCERNING CONSULTING
FEES**

AFFIDAVIT CONCERNING CONSULTING FEES

[The Contractor's "Affidavit Concerning Consulting Fees" that was submitted with the Contractor's "Notice of Award" will be added by CRRA.]

**AGREEMENT FOR
AIR EMISSIONS TESTING
AT THE
MID-CONNECTICUT POWER BLOCK FACILITY**

EXHIBIT H

**CONTRACTOR'S CERTIFICATION
CONCERNING GIFTS**

CONTRACTOR'S CERTIFICATION CONCERNING GIFTS

[The Contractor's "Contractor's Certification Concerning Gifts" that was submitted with the Contractor's "Notice of Award" will be added by CRRA.]

**AGREEMENT FOR
AIR EMISSIONS TESTING
AT THE
MID-CONNECTICUT POWER BLOCK FACILITY**

EXHIBIT I

**CRRA PRESIDENT'S CERTIFICATION
CONCERNING GIFTS**



**PRESIDENT'S CERTIFICATION
CONCERNING GIFTS**

**AGREEMENT FOR AIR EMISSIONS TESTING AT THE
MID-CONNECTICUT POWER BLOCK FACILITY**

Awarded To

[NAME OF CONTRACTOR/CONSULTANT]

(This CERTIFICATION is to be signed by the President of CRRA
at the time the Agreement is executed by him/her.)

By submission of this Certification, the President of the Connecticut Resources Recovery Authority ("CRRA") hereby certifies that the selection of the most qualified or highest ranked person, firm or corporation for the "Agreement for Air Emissions Testing at the Mid-Connecticut Power Block Facility" was not the result of collusion, the giving of a gift or the promise of a gift, compensation, fraud or inappropriate influence from any person.

Signature: _____

Name: **Thomas D. Kirk**

Title: **President**

State Of: **Connecticut**

County Of: **Hartford**

Thomas D. Kirk, being fully sworn, deposes and says that he is the President of the Connecticut Resources Recovery Authority, that he has read the forgoing statement concerning collusion, the giving of gifts or the promise of gifts, compensation, fraud or inappropriate influence and, under the penalty of perjury, certifies that each and every part of said statement is true.

Sworn to before me this _____ day of _____ 20 ____

Notary Public/Commissioner of the Superior Court